



Research: Lamp Quality & Flicker

Tech-Talks BREGENZ: Francis Wong

Application: Medical Fiber Optics Light Sources

Reliability: E-Caps & Optocouplers in LED Drivers

IMMEDIATE SHIPMENT FROM THE WORLD'S LARGEST  
SELECTION OF ELECTRONIC COMPONENTS™

# 1,300,000+

## Products In Stock

**FREE  
SHIPPING**  
ON ORDERS OVER €65\*  
  
DIGIKEY.COM

FIND CONTACT AND ORDERING  
INFORMATION FOR YOUR REGION AT  
**DIGIKEY.COM/EUROPE**



4.8 MILLION PARTS ONLINE | 650+ INDUSTRY-LEADING SUPPLIERS | 100% AUTHORIZED DISTRIBUTOR

\*A shipping charge of €18.00 (£12.00) will be billed on all orders of less than €65.00 (£50.00). All orders are shipped via UPS for delivery within 1-3 days (dependent on final destination). No handling fees. All prices are in euro and British pound sterling. If excessive weight or unique circumstances require deviation from this charge, customers will be contacted prior to shipping order. Digi-Key is an authorized distributor for all supplier partners. New product added daily. © 2016 Digi-Key Electronics, 701 Brooks Ave. South, Thief River Falls, MN 56701, USA





Messe München

Connecting Global Competence

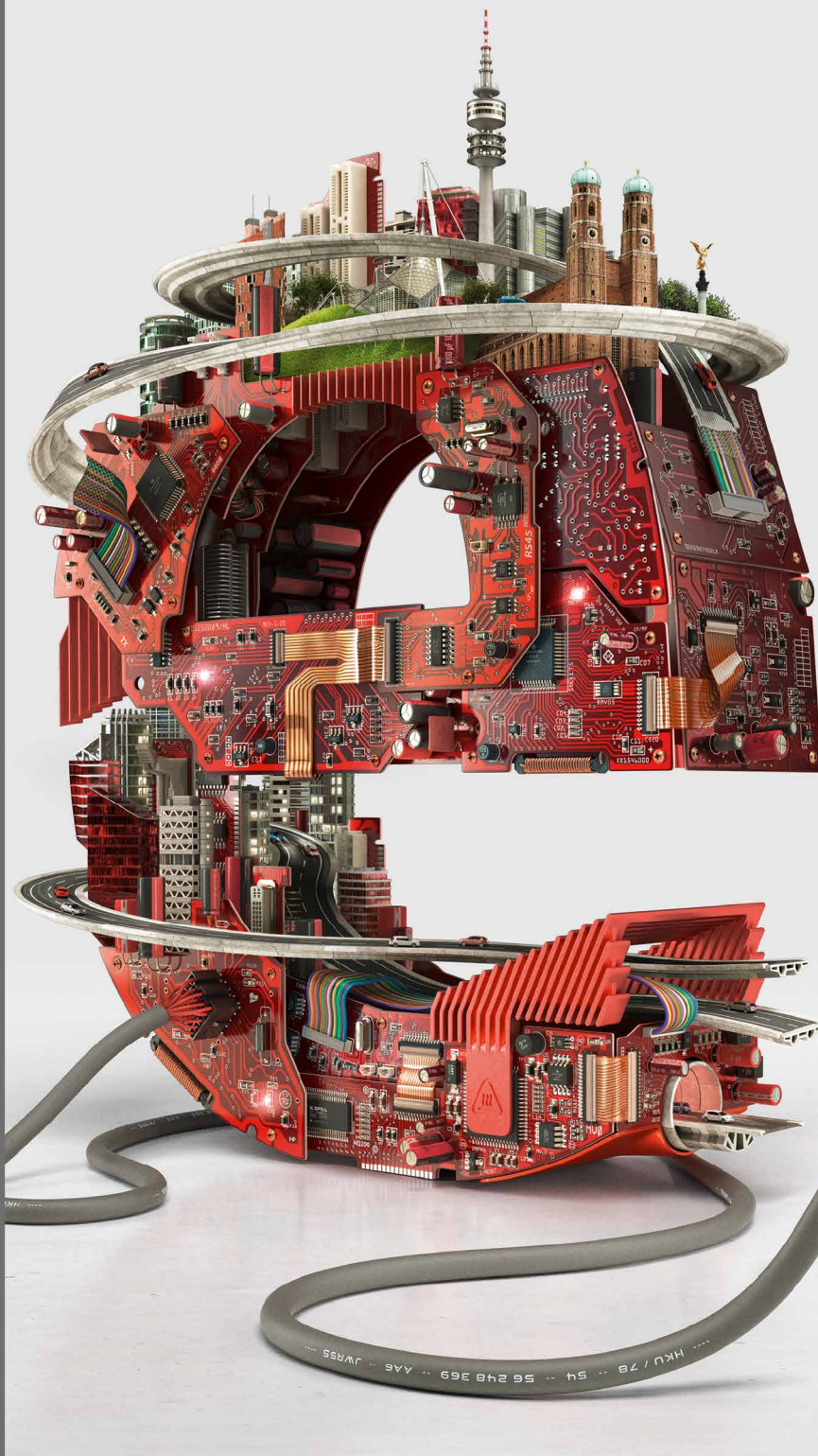

# Planet e: Where the future begins.

Electronics of tomorrow.  
Today.

Tickets & Registration:  
[electronica.de/en/tickets](http://electronica.de/en/tickets)

World's Leading Trade Fair for Electronic Components,  
Systems and Applications

Messe München | November 8–11, 2016 | [electronica.de](http://electronica.de)



**electronica** 2016

inside tomorrow



# Open Innovation in Lighting

Last month Luger Research e.U. organized a workshop on the topic of Pragmatic Open Innovation, led by Prof. Sergei Ikoenko. The workshop offered participants the chance to discuss the latest methodologies for innovation and problem solving with a leading expert on the subject of systematic innovation.

Reliability and Life-time, the main topic of this current issue, is highly driven by the quality of design-in and therefore innovative approaches and problem solving capabilities play an important role in designing long-lasting, high-quality products and systems. Consequently, Design for Six-Sigma (DFSS) is a key process element for developing new generations of products.

For those not familiar with the term, open innovation is a paradigm that assumes that companies can and should use external as well as internal ideas and internal and external paths to market, as the firms move to advance their technology. Systematic innovation is more of a scientific approach to open innovation execution that uses analytical tools to identify root causes of an innovation challenge and then finds functionally related practical solutions that can be adapted.

Systematic Open Innovation is based on nine, highly valuable tenets, namely: Use a scientific problem solving approach and don't simply rely on inspiration. Focus on functions, not design components. Address key problems, not initial problems. Resolve contradictions; don't compromise. Utilize global knowledge to complement your in-house expertise. Adapt existing solutions whenever possible. Only improve features the customer will pay for, not all features. Select evolutionary winners, not losers. Innovate the right product, not every product.

As a consequence of focusing on functions, rather than components, we can use function knowledge to apply the Function-Oriented Search (FOS), a problem-solving tool based on identifying existing technologies worldwide using function criteria. FOS is founded on a generalization of functions that allows for expanding the search of applicable technical solutions (not just in the lighting domain). This tool is more effective when searching in leading fields such as: Medicine, Aerospace, Automotive, Military, Toys, and Biology. For example, Intel found a solution for a high-tech chip production problem in the area of Champagne manufacturing.

The nine tenets should guide us when developing new lighting products and systems. Due to the short development cycles, pragmatic and systematic development processes are required to guarantee the needed quality. These new approaches in the methodologies and the new way of thinking open up borders, and the world-wide search in different domains may help to speed up processes and support the quality of designs.

In this issue we highlight quality concerns for LED Drivers, LED Lamps and Flicker. There are also articles that touch on the topics of recycling, circular economy and fiber optics in medical applications. In our Tech Talks Bregenz, Francis Wong from Lextar states his views on the development of quality in lighting.

If you would like to read more about systematic open innovation in our publications, please let us know.

Yours Sincerely,

Siegfried Luger  
Publisher, LED professional  
Event Director, LpS 2016

*Making LED Lighting Solutions Simple™*



**We Accelerate  
Time to Revenue  
by Providing**

- ▶ The Most Comprehensive System-Level Product Portfolio
- ▶ Solid-State Lighting Expertise
- ▶ Design Support Services
- ▶ Global Supply Chain and Business Solutions



**FUTURE**  
Lighting Solutions

[www.FutureLightingSolutions.com](http://www.FutureLightingSolutions.com)

COMMENTARY

08 Lifetime And Reliability  
by Dr. Günther Sejkora, items & LED professional

TECH-TALKS BREGENZ

34 Francis Wong, AVP Lighting Business Unit, Lextar  
compiled by Dr. Günther Sejkora, LED professional

RESEARCH

40 Quality and Health Aspects of LED Lamps for the European Residential Lighting Market  
by Prof. Dr. Georges Zissis, Paul Sabatier University of Toulouse

50 Flicker Beyond Perception Limits - A Summary of Lesser Known Research Results  
by Dr. Walter Werner, Werner Consulting

TECHNOLOGIES

58 Concepts to Overcome Lifetime Issues of LED Drivers  
by Maggie Nadjmi, SL Power Electronics

QUALITY

62 TM-30 or the Quest for New Metrics to Measure Light Color Quality  
by Arno Grabher-Meyer, LED Professional

APPLICATIONS

68 High-End White Light Sources Fiber Optics Technology for Medical Applications  
by Holger Laabs, Oliver Mehl & Henning Rehn, Osram

SPECIAL

74 LED Lamps Recycling Technology for a Circular Economy  
by A. Gassmann et al., Fraunhofer IWKS & Technische Universität Darmstadt

REGULARS

04 EDITORIAL  
08 COMMENTARY  
10 PRODUCT NEWS  
22 STANDARDIZATION NEWS  
23 RESEARCH NEWS  
26 EVENT NEWS

82 ABOUT | IMPRINT

HIGHLIGHT

50 Flicker Beyond Perception Limits - A Summary of Lesser Known Research Results  
by Dr. Walter Werner, Werner Consulting

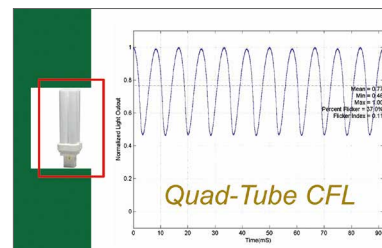

ADVERTISING INDEX

FUTURE LIGHTING SOLUTIONS	1	REFOND	19	INTERLIGHT MOSCOW	57
DIGI-KEY	2	LEDFRIEND	20	RUSALOX	61
ELECTRONICA	3	CREE	20	TOPSIL	61
FUTURE LIGHTING SOLUTIONS	5	GL OPTIC	22	HK INT. LIGHTING FAIR	65
GUZHEN LIGHTING EXPO	7	INFINEON	25	ILLUMINOTRONICA	67
LEDLINK	9	LOT QUANTUM DESIGN	26	PHOTOPTICS	71
EPISTAR	11	LED PROFESSIONAL SYMPOSIUM	27	CHINA INT. OPTOELECTRONICS EXPO	73
RECOM	13	INSTRUMENT SYSTEMS	39	MERCK	81
MÜHLBAUER	15	LED CHINA	48	LED PROFESSIONAL REVIEW	83
EUROLIGHTING	17	KDG -OPTICOMP	53	ACEVEL	84



# Lighting Fair The 18<sup>th</sup>

The 18th China (Guzhen)  
International Lighting Fair

**22-26** October 2016

Zhongshan, China

**Original Source of Lightings  
for 6 billion people worldwide**

**Register now,**

To save 100 RMB Admission Fee  
and get VIP upgrading!

 <http://www.gzlightingfair.com/en>  
 [chloe.qu@ubmsinoexpo.com](mailto:chloe.qu@ubmsinoexpo.com)

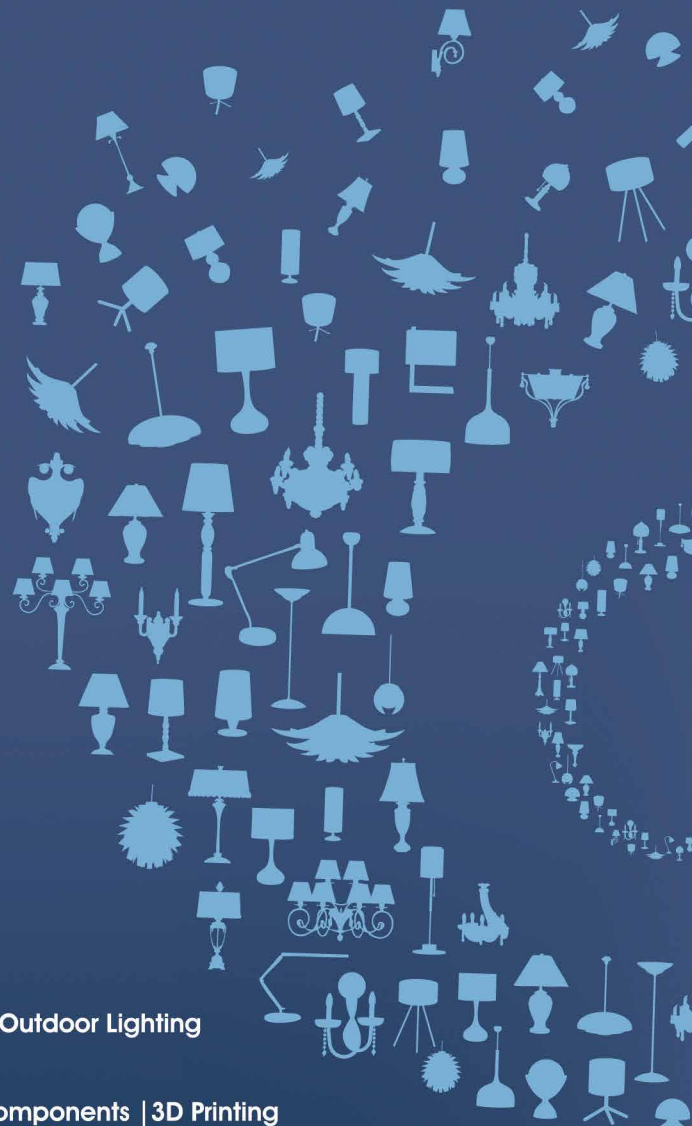

Decorative Lighting | Household Lighting | Commercial Lighting | Outdoor Lighting  
LED Lighting & Technology | Electrical & Electronic Product  
Machinery & Equipment | Raw Material | Lighting Accessories & Components | 3D Printing



### Günther Sejkora

Günther Sejkora received his PhD from the University of Innsbruck after studying physics, IT and mathematics. He spent more than 20 years in the Research & Development department at Zumtobel Lighting and then went on to start his own company, “items” where, together with industrial partners, he has carried out more than 50 R&D and technology projects in the fields of LED lighting and lighting controls. He was Managing Director of the Kompetenzzentrum Licht GmbH from 2010 to 2015 and is currently the Research and Innovation Manager at Luger Research.

## LIFETIME AND RELIABILITY

Although questions regarding lifetime and reliability of Solid-State-Lighting (SSL) products are essential for customers, knowledge about it is still fragmentary. It was easy to give answers to these questions in the times of conventional lamps (incandescent, fluorescent, high pressure): light output degraded over time and end of life was reached when light output fell below a certain level or when the lamp “burned out”. Lifetime was restricted by these events from several hundred up to 15,000 or 20,000 hours. This time was far below the useful lifetime of any other components in the luminaire. Only lifetime of the lamp was discussed at that time. When SSL entered the picture, the same concept was adopted and lifetime of the LED was promoted instead of talking about lifetime of a luminaire or a module.

Maybe we should first take a look at failure behaviour of components and products. A parametric failure occurs, when a performance parameter (e.g. light output or chromaticity for an LED) comes out of range and therefore the device can't be used any more. A catastrophic failure means that due to a spontaneous effect the component or product becomes inoperable and can't be repaired (e.g. burn out of a lamp filament). Both failures finish the lifetime of a product or component.

Typically, at the beginning of the product's life the failure rate starts at a certain level and drops, due to early failures, to a certain constant level where it stays until the beginning of the wear-out phase. The failure rate rises again due to catastrophic and parametric failures until the end of the product's life. For LED nearly all catastrophic failures occur during processing and installation of the LED product and after that lifetime is limited only by

parametric failures (depreciation of light output, color shift). This applies only for the LED and not for the power supply, driver and other components in the luminaire.

Does a high lifetime and high reliability of the LED automatically mean the same for an SSL product? Surely not! There are many components (power supply, drivers, optical elements, gaskets) with comparable or even lower lifetimes than the LED in a luminaire or module. Also, environmental conditions of the LED may differ according to the SSL product or the application where it is used. Lifetime of the product will be lower than the lifetime of each component integrated in the luminaire, reliability will be worse than reliability of each element in the product.

What customers really want to know are confinable figures for lifetime and reliability for the luminaire or the module. Up until now we don't have standardized methods to specify the lifetime of LEDs but at least we are on the way. Similarly, we could standardize specifications for lifetime of power supplies and drivers. Using mathematical algorithms we could at least calculate lifetime expectancies for the electronic parts of an SSL luminaire.

Maybe these figures for electronic components in luminaires will not tell the full truth about lifetime and reliability of LED luminaires or modules. Maybe we could do better integrating lifetime figures for other components in the product. But reliable figures for LED and electronics will be much better than anything we use today: estimations of LED lifetimes, determined without any standardized methods, without knowing the environmental conditions of the LED, without taking into account any other components. ■

G.S.



**NEW**

Ledlink Optics, Inc.



# PRODUCT | CONCEPT

MR11/MR16 (Silicone/PC Component)

▽ Light source: Silicone encapsulate LED+PCB

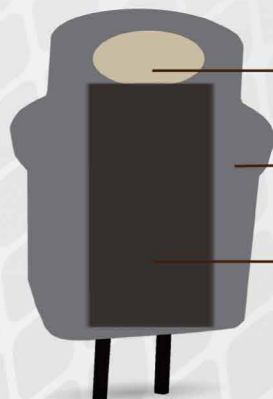

▶ LED

▶ Silicone

▶ PCB

*Characteristic :*

- *Insert molding process*
- *Silicone*
  - *High heat resistance*
  - *Good transparency*

▽ Assembly with transparent PC reflector  
Without extra heat sink

▽ Light Performance  
(Light output direction)



Our Services



▶ R & D

▶ Component solution

▶ Manufacture

▶ Customerization

Further technical information is available, please contact us for more details.

| [www.ledlink-optics.com](http://www.ledlink-optics.com) | [service@ledlink-optics.com](mailto:service@ledlink-optics.com)

 **LedLink**  
Linking LEDs to The Real World

## ROHM Expands Color Lineup of Class-Leading Thin, Compact LEDs

ROHM Semiconductor recently added 7 new colors to its PICOLED™ series of low-profile, ultra-compact chip LEDs optimized for wearable tech, portable devices, and drones, allowing for greater color expression and improved design freedom.

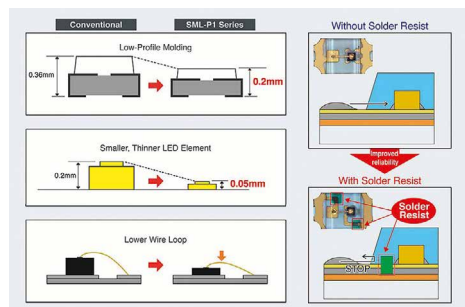

**ROHM's improved PICOLED™: Lower and smaller dimensions allow better applicability (left); the use of solder resist improves reliability (right)**

In recent years the number of applications that have adopted LEDs for lighting in conjunction with a notification function has grown significantly, and greater miniaturization at the component level is increasingly demanded in compact portable equipment. For drones, in particular, which are attracting attention in a variety of fields, adoption in new applications is expected, such as utilizing multiple drones that integrate LEDs in visual performances. Due to significant expansion in these markets a number of companies have begun focusing on proprietary designs that require compact LEDs in a wider selection of colors.

In response, ROHM developed the popular SML-P1 series of class-leading thin, compact chip LEDs, utilizing a comprehensive, integrated production system and leveraging its strengths in element technology to eliminate wavelength variations that in the past have proven problematic. As a result, ROHM was able to increase the number of colors from 8 to an industry-leading 15, providing unmatched compatibility.

In addition, combining a lower gold wire loop with a thinner light emitting element (developed using proprietary technology) makes it possible to achieve the thinnest form factor on the market at only 0.2 mm, contributing to greater compactness, lower profile and weight saving in mobile applications. Also, taking into consideration

usage conditions during reflow allowed ROHM to prevent solder intrusion into the resin by implementing penetration countermeasures within the package itself. This is expected to prevent failures caused by solder infiltration during the customer's soldering process, improving reliability considerably. And going forward, ROHM will focus on strengthening its PICOLED™ lineup to include high brightness types as well as expand its lineup of RGB LEDs capable of improved color mixing.

### The industry's first 15-color lineup:

Seven new intermediate colors have been added to ROHM's existing 8-color lineup, resulting in an unprecedented 15 colors offered - the most in the industry.

### The world's thinnest form factor (0.2 mm) developed using proprietary production technology:

ROHM successfully achieved the industry's thinnest (0.2 mm) form factor in a class-leading small package size (1.0 x 0.6 mm), while the lightweight design (0.2 mg) meets the need for weight reduction demanded by portable devices and drones. In addition, package miniaturization technology makes it possible to position the light emitting element in a 0.6 x 0.6 mm square area, providing square emission characteristics ideal for dot matrix displays.

### Solder intrusion countermeasures improve reliability:

A type of stopper called a 'solder resist' is implemented before the gold plating process to block the gold pattern (which features good wettability). This makes it possible to prevent solder from penetrating the resin, eliminating failures due to short-circuits and improving reliability considerably. ■

## Lumileds Expands and Improves Luxeon C Color Line

Lumileds, the global leader in light engine technology, expanded its line of Luxeon C Color LEDs to a total of 12 colors (and 8 whites), making it the industry's broadest line of color LEDs available. The Luxeon C Color Line is an optically advanced portfolio of LEDs that enables flawless color mixing because the focal length of each LED is identical, enabling maximum optical efficiency in design.



**Lumileds expands Luxeon C Color series with new CCT and CRI opportunities and a Far Red LED. Additionally, the typical flux of Luxeon C Red and Luxeon C Blue have been improved by 12%**

"Lumileds has filled out the spectrum on an LED color line that really sets the standard in color mixing. We're delivering seamless color mixing and the right colors for every application, including studio and stage lighting, architectural lighting, emergency vehicle lighting as well as color tunable lamps/fixtures," said Jennifer Holland, Product Manager for the Luxeon C Color Line.

The Luxeon C Color Line now includes Mint, Deep Red and Far Red colors, which join the existing offering of Red, Red-Orange, Amber, PC Amber, Green, Cyan, Blue and Royal Blue. In addition, the typical flux of Luxeon C Red and Luxeon C Blue have been upgraded by 12%, delivering even better output from two of the most commonly used colors.

The Luxeon C Color Line is the winner of two distinguished industry awards in 2016, the Sapphire Award from LEDs Magazine and the Product Innovation Award (PIA) from Architectural SSL. The Sapphire Awards recognize solid-state lighting innovations that are driving technology forward and revolutionizing the lighting market. The PIA Awards honor the most innovative solid-state luminaires and fixtures on the market as well as their components.

The white portion of the Luxeon C Color Line has been expanded to include color temperature and CRI combinations of 4000 K, 5000 K, 5700 K and 6500 K at 70 CRI; 2700 K, 3000 K and 4000 K at 80 CRI; and 5700 K at 90 CRI. The Luxeon C Color is the only line of color LEDs to be hot tested at 85°C to ensure performance at application conditions. With the industry's lowest thermal resistance (2.8 °C/W), users can save on heat sink cost or drive the LEDs harder to attain higher output than with a competitor's LEDs.

In addition to the expansion of the Luxeon C Color Line, Lumileds announces the addition of a Far Red offering to the Luxeon Rebel Color Line, a portfolio known for its leading light output, high efficacy and clear saturated colors. Additionally, the Luxeon Rebel Green, Cyan and Blue colors now feature 12% higher flux than the previous generation emitters. ■

## Cree Expands Portfolio of LEDs for Horticulture Lighting

Cree expands its industry-leading portfolio of LEDs optimized for horticulture lighting with the introduction of the new Cree XLamp XQ-E Photo Red LED. The XQ-E Photo Red LED is capable of providing very high levels of growth-promoting light wavelengths from a footprint that is less than one-third the size of its closest competitor with similar output. The new XQ-E LED extends the family of smallest LEDs optimized for horticulture and enables lighting manufacturers to reduce the size of luminaires and lower their system cost.

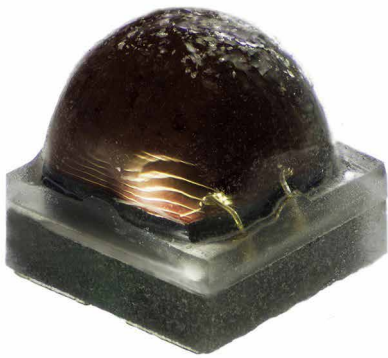

**Cree's XQ-E Photo Red LED is designed to provide very high levels of growth-promoting light wavelengths**

This addition expands Cree's wide range of XQ and XP LEDs that deliver the industry's highest Photosynthetic Photon Flux (PPF), efficiency and reliability. Both LED families enable the replacement of incumbent lighting technologies at radically lower power with similar spectral content. For example, a high-bay reference design built using Cree white and photo red LEDs deliver higher average PPF Density than a 1000 W double-ended high pressure sodium (HPS) fixture while drawing half the power.

"Cree LEDs enable us to offer full spectrum LED grow lights that truly mimic natural sunlight," said Rami Vardi, chief executive officer, Spectrum King LED. "The high performance, high efficiency and high reliability of Cree LEDs allow us to match the intensity of traditional HPS lamps at a lower system cost, longer life and lower power."

The XQ-E Photo Red LED is capable of delivering over 6.4  $\mu\text{mol}/\text{sec}$  of the 660 nm peak wavelength light that can be beneficial for plant growth from a 1.6 x 1.6 mm footprint. Cree's white and color LEDs deliver the full spectrum of light and mimic natural sunlight. Cree's color LEDs, including royal blue, green, red, photo red and far red LEDs, deliver high PPF in the wavelengths best-suited for the different stages of plant growth. The combination of consistent packages, footprints and drive currents allow easy tuning of spectral

# EPISTAR

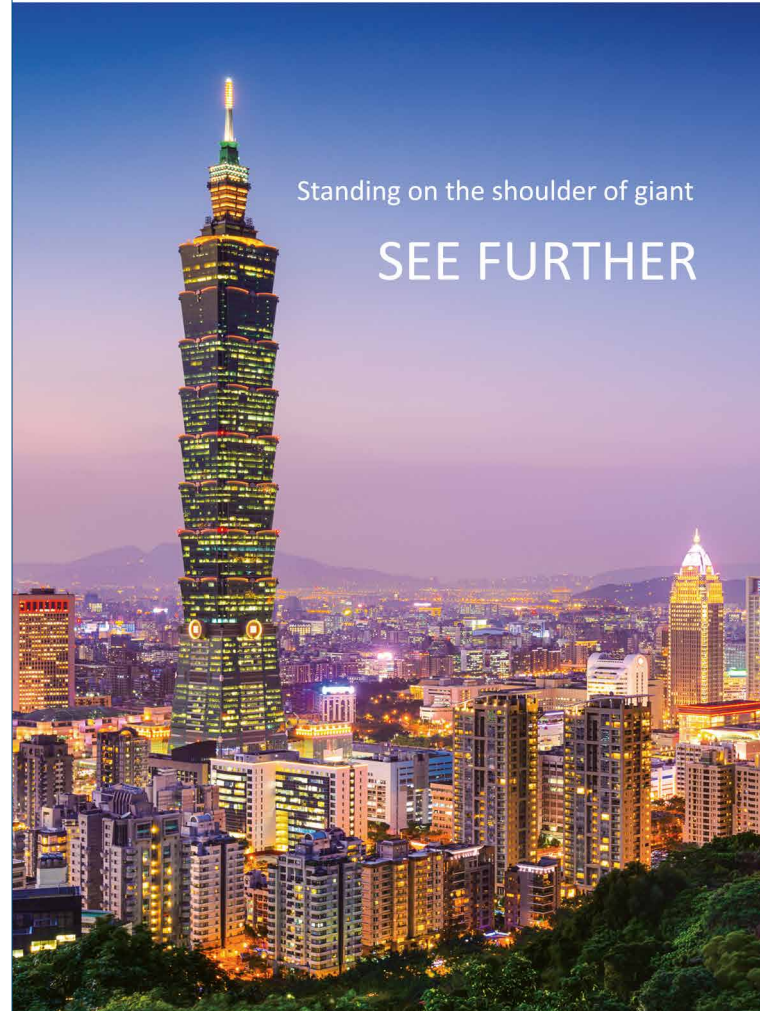

Standing on the shoulder of giant

SEE FURTHER



Learn more about our  
[Co-activation Service Model](#)

EPISTAR Corporation  
5 Li-hsin 5th Road, Hsinchu Science Park,  
Hsinchu 300, Taiwan  
T: +886 3-567-8000 F: +886 3-579-0801  
[www.epistar.com](http://www.epistar.com) [sales@epistar.com](mailto:sales@epistar.com)



Website Facebook

content and intensity at the luminaire level. Cree's new photo red LED leverages the XLamp XQ-E family's proven optical symmetry and consistency across all colors to improve color uniformity and simplify the production process for lighting manufacturers.

"Our mission at Local Roots is to improve global health by building a better food system, and that means growing food in a responsible way at a cost that increases access to fresh and delicious produce," said Matt Vail, chief operating officer, Local Roots. "Cree's wide range of high performing LEDs optimized for horticulture allows us to control spectrum and intensity and provide our crops precisely the light they need in order to maximize growth, nutrition and quality. The high efficiency and long-term reliability of Cree LEDs enables us to lower the cost of the food we grow and feed more people better food." ■

## Samsung Adds New Line-Up of CSP LEDs for Automotive Lighting

Samsung Electronics Co., Ltd., a world leader in advanced component solutions, announced introduced "Fx-CSP", a line-up of LED packages which features chip-scale packaging and flexible circuit board technology, for use in automotive lighting.

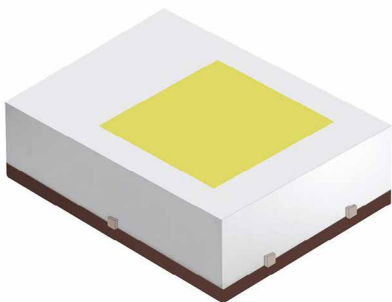

**Samsung's new Fx-CSP series covers 1 to 40 W as a single chip or array package solution. It is based on chip-scale packaging and flexible circuit board technology**

"Our new Fx-CSP line-up will bring greater design flexibility and cost competitiveness to the automotive lighting industry," said Jacob Tarn, executive vice president, LED Business Team, Samsung Electronics. He added that, "We will continue to introduce innovative LED products and technologies, such as multi-chip array technology, that can play a key role in the growth of the automotive LED lighting industry."

### Product line-up:

- Fx1M:
  - Chip arrangement: 1x1
  - Luminous flux (lm): 120 (typ. 350 mA)
  - Power consumption (W): 1
  - Application: Daytime running lamp, Position lamp
- Fx1L:
  - Chip arrangement: 1x1
  - Luminous flux (lm): 300 (typ. 1 A)
  - Power consumption (W): 3
  - Application: Daytime running lamp
- Fx4:
  - Chip arrangement: 1x4
  - Luminous flux (lm): 1200 (typ. 1 A)
  - Power consumption (W): 14
  - Application: Headlamp, Light guide type daytime running lamp
- Fx2x6:
  - Chip arrangement: 2x6
  - Luminous flux (lm): 300 (1 chip) (typ. 1 A)
  - Power consumption (W): 3 (1 chip)
  - Application: Multi-beam headlamp
  - Samsung's new Fx-CSP LED line-up was recently selected for a compact car headlamp project from one of the major global automotive manufacturers

Samsung's new Fx-CSP provides an advanced combination of chip-scale packaging and flexible circuit board technology, which together enable more compact chip sizing and a higher degree of reliability. The use of a flexible circuit board also enables more heat to dissipate, which leads to lower resistance and brings about a greater degree of lumen-per-watt efficiency than using a ceramic board.

In addition, the new Samsung automotive LED line-up allows car designers to use a variety of chip arrangements such as a single chip, a 1 by 4, or a 2 by 6 multi-chip arrangement to suit different lighting configurations. The Fx-CSP line-up can be widely used in automotive lighting applications that include position lamps and daytime running lamps as well as headlamps that require higher luminous flux and reliability than other automotive lamps.

The Fx-CSP line-up consists of single packages, Fx1M and Fx1L, with 1-3 watts each, as well as packages with a 14 W high voltage array, Fx4 and a 40 W high voltage array, Fx2x6. The variation in wattage levels allows Samsung LED lighting packages to work well with a wide range of exterior automotive lighting.

By adding the new Fx-CSP line-up to its existing mid-power and high-power automotive LED component line-ups, Samsung now provides a highly competitive family of automotive lighting components. ■

## New High Efficacy XT-E LED Delivers 25 Percent Higher Lumens-Per-Watt

Cree significantly improves the popular XLamp® XT-E LED. Leveraging key elements of Cree's SC5 Technology™ Platform, the upgraded XT-E LED family now includes a new High Efficacy (HE) option that delivers a 25 percent increase in efficacy compared to the previous XT-E LED and provides a guaranteed minimum efficacy of 164 LPW at 85°C and 350 mA. These improvements make 130 LPW or higher at the system level achievable under real operating conditions and enable existing customers to quickly upgrade system performance of applications, such as outdoor and industrial lighting, while still achieving the lowest total cost.

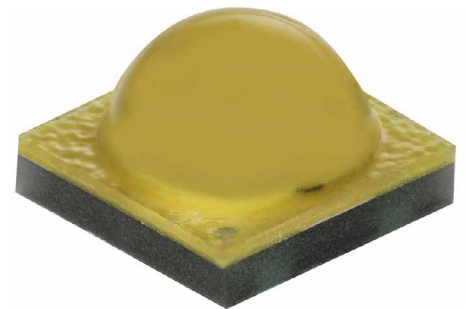

**Cree's new, enhanced XT-E LEDs with 20% higher efficacy redefines price-performance for HP LEDs**

"We are committed to building the most energy-efficient industrial lighting systems and the newly improved High Efficacy XT-E LED enables us to do that without any additional investment or requalification," said Colin Piepgras, vice president of engineering at Digital Lumens. "With the new XT-E LED, we are able to leverage existing optical, mechanical and electrical design elements to quickly improve our portfolio of intelligent lighting solutions."

The enhanced XT-E LED improves the brightness, voltage characteristics and optical performance in the same, proven 3.45 x 3.45 mm XT package. Demonstrating the excellent long-term reliability of Cree's high-power ceramic LEDs, the XT-E LEDs now have more than 10,000 hours of LM-80

data available, delivering reported L90 lifetimes of greater than 60,000 hrs, at 105°C, 1A. This industry-leading reliability is ideal for applications like outdoor and high bay lighting where long lifetimes at high ambient temperatures matter. For example, XT-E's improved efficacy and reliability make it well-suited for the recently updated DLC 4.0 requirements.

"Our customers rely on Cree for innovations that allow them to upgrade their existing products to both gain a competitive edge and meet increasing industry requirements," said Dave Emerson, vice president and general manager for Cree LEDs. "Cree's improved XT-E LED provides an immediate solution that eliminates the time and cost of redesign around unproven alternatives." ■

## New LED Series for Exterior Automotive Applications

Everlight, a leading player in the global LED and optoelectronics industry, presents four new ceramic high reflective packaged high power automotive LEDs with a Golden Lead Frame in four different colors White, PC-Amber, Red and Super Red, according to their preferred exterior applications.



Everlight's 3030CLU(AM) Series has a variety of colors that correspond to different applications. The structures and materials are dependent on the client's demands

3030CLU-NP (White) features a cool color temperature of 5180-6680K which makes it especially suited for DRL. Version 3030CLU-UY (PC-Amber) is recommended for turn indicators and tail lights. As for CHMSL, brake lamps and rear combination lamps, Everlight introduces red and super red color options. Both 3030CLU-URR (Red) and 3030CLU-USR (Super Red) with a

wavelength of 612-624 nm and 627-639 nm respectively provide a high luminous flux @350 mA. 3030CLU-USR (Super Red) is based on European OE's preference and provides an even more vivid, thus easier to recognize red color, which is also expected to help reduce car accidents.

Everlight's 3030CLU(AM) Series with a compact size (3.0x3.0x0.8 mm) and a wide viewing angle of 120° is offered in a golden high reflective package. Using a ceramic substrate results in lower costs and a low thermal resistance of less than 7°C/W for optimized heat management. A further benefit is a junction temperature of up to 150°C (Tj150°C) and still keeping good performance. Usual 3030 packages are destroyed at this temperature, whereby EVERLIGHT's 3030CLU(AM) is even more perfectly suited for demanding exterior automotive applications. A golden lead frame improves sulphur resistance.

Everlight 3030CLU(AM) LED packages have passed qualification according to AEC-Q101 and comply with the highest MSL standard MSL1. The MSL (moisture sensitivity level) is an electronic standard for the time period in which a moisture sensitive device can be exposed to ambient room conditions. That means 3030CLU(AM) is considered as being not moisture sensitive in any possible circumstances, does not require dry packing and thus is suited for an unlimited storage period until mounting. The devices are also ESD protected for voltages up to 8 KV.

The professional R&D, sales and marketing team of Everlight is always on a quest for innovations and technical breakthroughs. Everlight is committed to a complete set of management system certifications, including TS-16949, OHSAS 18001, ISO 14001 for production quality. All automotive products comply with AEC-Q101 (Automotive Qualification Requirements for Discrete Product) and other highest criteria. With ever increasing demands on LED automotive applications, Everlight has cooperated with major car lamp manufacturers for premium designs that fulfill top LED product demands, winning great trust in the OE market by the public. ■



## SUPER FLAT LED DRIVER

IDEAL FOR FURNITURE, COVE AND CABINET LIGHTING

- RACD-LP & RACV-LP SERIES
- 6/12/20 WATT
- 0.35A TO 0.7A CC OUTPUTS  
12V & 24V CV OUTPUTS
- LOW PROFILE 11MM/13MM HEIGHT
- INTEGRATED INPUT FUSE AND  
OVERTEMPERATURE PROTECTION
- -20°C TO +50°C AMBIENT TEMP.



**RECOM**  
LIGHTING

[www.recom-lighting.com](http://www.recom-lighting.com)

## Lumileds Upgrades the LUXEON CoB Compact Range (Gen 2)

Lumileds has launched its second generation LUXEON CoB Compact Range LEDs, which feature an efficacy and output boost of up to 16% over its previous generation arrays. The new product line reinforces Lumileds' leading position in chip on board technology by enabling the most cost effective solid state PAR, GU-10 and MR-16 lamps for retail, hospitality and home lighting applications.



**Lumileds' LUXEON CoB Compact Range (Gen 2) reaches efficacy levels of up to 130 lm/W and delivers exceptional "punch" for spotlights and directional lamps**

Due to the common Light Emitting Surface (LES) of 6.5mm across the LUXEON CoB Compact Range Gen 2 LEDs, different power range directional lamps such as a 35 W equivalent and a 50 W equivalent MR-16 lamp can use the same optic, minimizing design and system cost. The upgraded arrays also achieve unsurpassed center beam candlepower (CBCP) or "punch." At 1,500 lumens, the LUXEON CoB 209 reaches 76,000 candelas at a 10° beam angle.

"Customers currently using first generation LUXEON CoB Compact Range are also particularly excited about this upgrade because they can replace a Gen 1 Compact Range 109 with a Gen 2 Compact Range 205 to attain the same performance at a significantly lower cost, or they can replace a Gen 1 Compact Range 105 with a Gen 2 Compact Range 205 and boost output by 16% in efficacy," said Ivan Tsoi, Product Manager for LUXEON CoB Compact Range at Lumileds. The performance boost, combined with the industry's lowest thermal resistance, leads to smaller heat sinks and more cost efficient lamps.

The LUXEON CoB Compact Range LEDs are offered in the industry's widest range of color temperatures (2200 K to 5700 K) and CRIs

(80 and 90). The range is also available with Lumileds' award-winning CrispWhite Technology designed for to be used in fashion retail lighting to reveal the richest whites, most vibrant reds and to make all colors pop. 100% of LUXEON CoB Compact Range arrays are hot tested at 85°. ■

## Adura LED Solutions Introduces Nichia 229 LED Based Modules

Adura LED Solutions, a company focused on LED lighting solutions, introduces a new product to its family of 2x2 MX and 2x6 LED lighting solutions with the new NICHIA 229 LED. Adura LED Solutions new N229 LED Module family provide high performance to help designers with best in class heat dissipation, longer life and better overall Luminaire performance.



**Adura LED Solutions' highly efficient new Nichia 229 LED based modules are offered at a CCT of 3000K, 4000K, 5000K and 70+ CRI**

### Key Specifications @ 5000K:

- 2500 - 7,500 lm
- 151 lpw (LEDiL 2x6 IP Compatible Lens)
- 70+ CRI

Modules continue to be a popular building block product for luminaire manufacturers that want to accelerate the product development cycle. With the new 229 product modules, Adura is delivering the light output required to enable a new level of performance in luminaires. The new 229 modules are compatible with LEDiL 2x6 & 2x2 MX Strada product family and is offered at a CCT of 3000 K, 4000 K, 5000 K and 70+ CRI.

Modules are geared toward a wide range of applications such as roadway, parking and industrial. Each module integrates 4 or 12 N229 LEDs compatible with LEDiL 2x2MX and 2x6-IP STRADA optic family. As a leading manufacturer of high-quality LED

modules, Adura LED Solutions (ALS) offers excellent quality products with a competitive price and exceptional customer service. ■

## Tridonic Introduces CLE Quadrant G2 ADV LED Module

The new generation of the LED modules CLE Quadrant G2 ADV (Advanced) now offers even greater flexibility for luminaire manufacturers for round ceiling and pendant luminaires. High efficiency and a high luminous flux are now not just available optionally but can be combined in a single module.

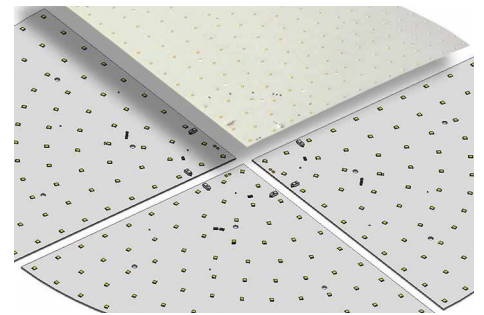

**Tridonic's new TALEXEngine CLE Quadrant G2 ADV is available in CCTs from 3,000 K, 3,500 K and 4,000 K offering a module efficiency of up to 185 lm/W**

### Main Features:

- Ideal for round shaped and flat ceiling and pendant luminaires
- The solution to realize XXL luminaires
- For uniform illumination of prestige areas or rooms designed to impress
- High Output and High Efficiency Mode enables more flexibility on luminaire design
- Narrow diffuser distances possible
- Small color tolerance (MacAdam 3) (1)
- Color temperatures 3,000 and 4,000 K
- Long life-time: 50,000 hours
- 5-year guarantee
- Perfect system solution with TALEXX PREMIUM Ip drivers

(1) Integral measurement over the complete module

The new generation of the LED modules CLE Quadrant G2 Advanced continues the tried and tested Quadrant concept for round ceiling and pendant luminaires, but now offers even greater flexibility. Three new sizes are available with diameters of 522 mm, 802 mm and 1082 mm so that very large luminaires can now be fitted with the

modules. One module consists of four segments that can be randomly combined and extended with additional ring segments for extra-large luminaires. The 2<sup>nd</sup> generation modules need no lenses, but nevertheless ensure a homogeneous illumination of the relevant luminaire with no shadow effects through the close-fit arrangement of numerous LEDs. This allows the realization of very flat luminaire designs with a high homogeneity.

The modules achieve a module efficiency of up to 185 lm/W. Various color temperatures of 3,000 K, 3,500 K and 4,000 K are available for a wide range of uses. A CRI 80 speaks for a good color rendering, the narrow color tolerances correspond to MacAdam3. Combined with the manufacturer's own Premium-LED Drivers, this provides an efficient system solution for dimmable luminaires with a homogeneous light emission that puts representative areas in retail and hospitality applications in the right light. ■

## Tridonic Introduces Robust LED Modules for Outdoor Applications

Tridonic's RLE EXC OTD 2x4/ 2x8 HP LED modules are resistant to overvoltage and are geared towards demanding outdoor and industrial applications. They can be combined with standard lenses and support modular luminaire design. Thanks to a variety of beam characteristics many different lighting scenarios can be created.

The robust TALEXXmodule RLE OTD EXCITE 2x4 / 2x8 HP high-performance modules stand for a durable lighting system which, thanks to an efficiency of up to 161 lm/W and 4 kV overvoltage protection, offers impressive performance both in outdoor and industrial applications in an extended temperature range from -40 to +105 °C. The modules have passed the test carried out in an environment of saltwater and fog according to IEC 60068-2-52 and are also resistant to hydrogen sulfide (GR-1217-CORE).



Tridonic's new RLE EXC OTD LED modules are robust high performance modules with up to 161 lm/W and 4 kV overvoltage protection

The associated optics can be freely selected so that the lighting can be adapted to a wide range of requirements, offering enormous flexibility. Depending on the beam characteristic, a symmetrical or asymmetrical distribution of light with wide or narrow beam angles is possible. This enables floodlight to be generated and rooms with particularly high ceilings such as the ones in factories and warehouses to be illuminated. A very long life of 100,000 h at an operating current of 700 mA (L80 B10 at 105 °C at the tc point, or L90 B10 at < 80 °C at the tc point)

## REEL TO REEL FLIP CHIP LED ASSEMBLY

SAVE UP TO 30% ON COST WITH MÜHLBAUER'S NEW HIGH SPEED LINE

 **Mühlbauer**  
High Tech International



- Produce LED light engines directly on flexible tape with final circuit layout → level 2 assembly
- Reel to Reel production mode in only one machine from Epoxy, to Flip Chip LED (CSP), incl. SMD component attach, curing and final test
- Profit from the latest technologies in Flip Chip LED, Direct Die Attach and Wafer-to-Wafer process
- Save up to 30 percent on production cost
- Multi chip bonding for super high resolution display application
- Super high speed panel or flex PCB bonding machine based on DDA technology
- Profit from our knowledge and long term experience in chip handling since 1986

Contact us today for more information on Mühlbauer's EL series!



[www.muehlbauer.de](http://www.muehlbauer.de)

reduces maintenance considerably. The manufacturer offers support for the thermal design of the components, ensuring long-term reliable operation in L90 B10. If a temperature sensor is required that allows power reduction to protect the technology, the modules are also available with external and internal logic. Both versions are protected against polarity reversal.

M3 screws can be used to install the LED modules in the luminaire together with the selected lens. By means of M4 connectors they can also be installed directly in the luminaire head, making assembly much easier.

In combination with a driver and ready2mains programmer, the LED modules can be easily programmed via the mains and can be adapted to changing lighting scenarios. In future, net4more, the new hardware and software platform, will open up even more possibilities for scalable and connected lighting thanks to its open interfaces. ■

## Cost and Performance Optimized Sensor-Based Control for LED Lighting Systems

Dialog Semiconductor plc, a provider of highly integrated power management, AC/DC power conversion, solid state lighting and Bluetooth® low energy technology, announced the addition of ambient light and color sensor controls to its smart lighting platform of advanced LED drivers and Bluetooth controllers. This represents another significant milestone in the recently announced joint venture with Dyna Image as both companies continue to combine their core technologies to provide complete platform solutions.



Sensor technology from Dyna Image joint venture with Dialog Semiconductor creates high growth opportunity in the emerging smart lighting market

In recent months, Dialog and Dyna Image successfully collaborated on a wearable reference design integrating Dyna Image's all-in-one optical heart rate monitor and MEMS (micro-electromechanical systems) accelerometer sensors with Dialog's SmartBond™ DA14580 Bluetooth® System-on-Chip (SoC) and sensor fusion software to provide a complete turn-key reference design for wearable fitness bands. Now, just a few months later, the two companies have brought their proven technologies in SSL and optical sensing together to deliver cost and performance optimized sensor-based control to LED lighting systems.

Integrating color sensing with Dialog's tunable-white driver allows lamps to automatically change their color temperature from cold (blue-white) to warm (amber) in tune with the ambient environment. One application is auto-tuning lamps, which work together with other lamps to provide a more consistent, pleasant light experience. This sensing feature also facilitates automatic compensation for normal variations in color temperature between LED light fixtures. Other applications include the ability to sense color temperature outdoors and replicate it indoors. This creates a natural light experience to help stimulate the human body's circadian rhythm, which is claimed to produce significant health and wellbeing benefits.

Dialog is already a leading supplier of driver integrated circuits in SSL. In smart lighting, its partnership with Dyna Image significantly increases the company's share of the bill-of-materials (BOM) in lighting fixtures: wireless Bluetooth control, optical sensor control, and advanced digital and TRIAC dimming drivers.

"As the SSL market goes mainstream with 60 watt equivalent lamps using Dialog drivers retailing at mass market prices, the lighting industry is looking for creative ways to add value and differentiate its products," said Mark Tyndall, SVP of Corporate Development and Strategy at Dialog. "Smart lighting is an emerging market where we see significant product innovation and huge growth opportunity. Adding Dyna Image's optical sensors to Dialog's smart lighting platform enables our customers to quickly deploy world-leading lighting products into this fast growing market." ■

## Power Integrations' LYTSwitch-1 Reduces Complexity in Bulbs, Tubes and Ballasts

Power Integrations announced its LYTSwitch™-1 single-stage, non-isolated, buck topology LED driver IC family. Featuring a very compact footprint, the IC enables the design of LED bulbs and tubes with high constant-current accuracy while using a minimum number of components. A novel driver algorithm ensures high power factor (PF) and low total harmonic distortion (THD) while maintaining very high efficiency.



Power Integrations' LYTSwitch-1 high PF, low THD LED driver ICs set a new standard in efficiency

Housed in a compact SO-8 package, LYTSwitch-1 ICs are greater than 93% efficient with a PF of over 0.9 and THD as low as 15%. Devices can be used in a low-side buck topology for reduced EMI or in a high-side buck topology which simplifies design. Delivering up to 22 W without a heatsink, the universal input (100 - 308 VAC) ICs incorporate a 725 V MOSFET for high reliability. Designers can make use of small, off-the-shelf inductors due to a unique peak current control algorithm. The new devices meet all applicable international standards including: DOE 6 (external power supply), CEC Title 20 and 24, ENERGY STAR® SSL, EN61000-3-2 (C) plus China and India standards.

Hubie Notohamiprodo, director of product marketing at Power Integrations commented, "Low system complexity and high performance make LYTSwitch-1 ICs ideal for both commercial and residential lighting applications. The low component count and compact size make these LED driver ICs easy to fit into space-challenged applications such as tube end caps, small form factor candles and GU10 bulbs, as well as low cost A19 and decorative-filament lamps."



In common with all Power Integrations products, LYTSwitch-1 LED driver ICs have a host of protection features including thermal foldback with end-stop shutdown, short circuit protection, input and output OVP, overcurrent and SOA protection. ■

## New 1,200/1,500 mA DC-DC CC LED Drivers from Mean Well

Mean Well has released LDD-L, LDD-H and LDB-L series into the DC-DC LED constant current driver market for years and has been widely adopted. In order to further meet the application demands, Mean Well pushes the output current of LDD-H series up to 1200/1500 mA and is pleased to unveil LDD-1200-1500H/HW models.

These two series are both constant current step-down mode power module with 9-52 VDC high voltage input and 2-46 VDC output. Having both the PIN style (H-Type)

and the wire style (HW-Type), the internally potted design makes them able to withstand water and dust. Both exploit non-isolated buck topology design that the highest working efficiency reaches 96%. The dimension of the whole LDD-H/HW family are all 31.8 x 20.3 x 12.2 mm; it is convenient for those lighting system designers who have already adopted products of Mean Well but require a higher output current to upgrade by using new drivers directly without changing the initial circuit design.

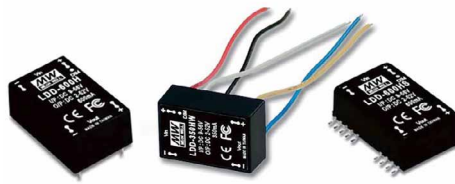

Mean Well's latest DC/DC LED drivers push the output current limits to 1200 mA and 1500 mA respectively

### Features:

- Constant current step-down mode
- Wide input (9-52 VDC) and output (2-46 VDC) range
- High working efficiency up to 96%
- Wide working temperature range: -40~+85°C
- Comply with EMI without any additional components (EN55015 and FCC part 15)
- Protections: Short circuit / Over temperature
- 94V-0 flame retardant plastic case
- Built-in PWM dimming and remote ON/OFF control functions
- FCC/CE approved
- Dimensions (LxWxH) 31.8 x 20.3 x 12.2 mm
- 3 years warranty

The typical applications of DC-DC LED constant current drivers is to connect them in back of the AC-DC constant voltage type LED drivers, providing a constant current to drive the LED luminaires that reach the stable constant current state and extend the life-span of the luminaires. These products are very suitable to be applied to the outdoor

## NEW! New AC Technology replaces powersupplies for LED!

### All (components) on ONE MODULE



This new AC technology replaces conventional power supplies by working without capacitors, inductors and all components which have limited lifetime. By newest IC technology the complete driver can be placed on a LED module for direct connection to 230 VAC.

This dramatically increases the reliability and lifetime! It saves space, reduces weight and is dimmable (symmetrical illumination). Modules from 3 Watt (30 mm dia) up to 40 W (54 mm dia) are standard products and samples are available ex works!

*You design the lamp – we supply the light!*

- » Custom designs are available on request
- » The driver circuit includes a bridge-rectifier fuse, varistor and NTC for internal temperature control (max + 85°C)
- » The modules can be operated in AC and DC!
- » CRI > 80 > 90, CCT 2700 K up to 5800 K
- » PF > 98, connecting to DALI is possible, THD > 20%
- » Isolation proof > 3 KV acc. IEC 61347, IEC 60598, IEC 60204
- » Expected lifetime > 50.000 h
- » EMI tested
- » Working temperature -40 ... + 85°C
- » CE / TÜV and UL certified

**euroLighting**

72202 Nagold · Tel.: 07452 6007-16  
www.eurolighting.de

or indoor LED lighting systems which utilize Mean Well's AC-DC LED drivers such as: street lighting, landscape lighting, tunnel lighting, household lighting, commercial lighting, and so on. ■

## High Power-Factor Buck LED Driver Meets Worldwide Retrofit Lamp Requirements

Diodes Inc., a leading global manufacturer and supplier of high-quality application specific standard products within the broad discrete, logic, analog and mixed-signal semiconductor markets, announced the AL1676. This universal AC-input LED driver is designed to meet or exceed worldwide power-factor regulations for non-dimmable retrofit LED bulbs and tube lighting, providing a design that also delivers high efficiency and a low BOM cost. Options for the integrated MOSFET allow for 300 V to 650 V drain voltages and 1 A to 4 A drain currents in order to suit most 3 W to 18 W bulb requirements.



Diodes' AL1676 universal AC-input LED driver IC is designed to reduce BOM and costs

High power-factor operation is achieved with a single-stage buck converter topology, which uses constant on-time control and a simple closed loop to ensure the AL1676 delivers an accurate constant LED output current with good line and load regulation. Operating in boundary conduction mode eases EMI/EMC design requirements while the ability to detect off-time helps eliminate the need for an auxiliary winding, contributing to the device's very low BOM count and cost.

The AL1676 includes multiple protection features such as under- and over-voltage, over-temperature and thermal fold-back that all help to increase system reliability within the high ambient temperatures encountered

in an LED bulb. The high level of integration coupled with a small 5 x 6 mm SO-7 package also enable a very compact solution size, reusing the same design footprint for different wattage bulbs by virtue of the MOSFET options. ■

## GlacialPower Launches Efficient and Reliable 100 Watt LED Driver

GlacialPower, a division of LED technology manufacturer GlacialTech Inc. is pleased to announce the GP-LS100P-36 1E, a 100 Watt LED driver with a 40V DC output. This rugged and reliable driver is suitable for demanding outdoor or indoor applications—including locations with challenging environmental conditions and fluctuating power supplies – thanks to its very wide input range of 90 to 305 VAC and 47 to 63 Hz, IP67 waterproofing and dustproofing, and full OVP, OCP, SCP, and OTP protection. The GP-LS100P-36 1E is compliant with tough new EU directives for power efficiency, and also offers constant current and constant voltage operation modes.



Glacial's new GP-LS100P-36 1E LED driver handles a wide range of environments, variable power conditions, and offers extensive safety features

### Key Features:

- Universal AC input, from 90 to 305 VAC
- Active Power Factor Correction is built in
- Safety protections include OVP, OCP, SCP, and OTP
- Constant current and constant voltage modes
- IP67 rated for protection from water and dust
- Compliant with the ErP (EU) No. 1194/2012, Stage 3 directives
- Consumes less than 0.5W when the unit has no load
- Takes less than 0.5 seconds to start up at 230VAC
- Waterproof connectors

GlacialPower focuses strongly on environmental protection and power cost reduction with this new LED driver. The driver is fully compliant with Stage 3 of the stringent ErP (EU) No. 1194/2012 directive which aims to greatly enhance the efficiency of energy-related products. The GP-LS100P-36 1E provides active power factor correction for highly efficient use of input power, as well as high power output efficiency. Power consumption is reduced to a very low 0.5 Watts when the unit has no load, in order to easily achieve a much greater energy saving during inactive periods.

The GP-LS100P-36 1E provides high output voltage quality to protect your LED lighting units from harm and also provides a pleasing lighting environment for your staff and customers. The driver's output voltage is clean and stable, with minimal ripple effects and very low noise (below 180 mV), ensuring a constant, flicker-free LED light or other adverse effects. This product provides a highly responsive setup time, under full load, of no more than 0.5 seconds at 230 VAC, and no more than one second at 115 VAC, ensuring extremely timely provision of attractive light on demand, whenever users require it.

In order to serve a very wide range of user applications and demands, this versatile LED driver can handle some of the most challenging lighting environments and weather conditions, indoors and out. It is protected from environmental threats by its IP67 rated enclosure, which is both waterproof and dustproof. Safety and long, maintenance-free life is further assured by a full range of electrical and thermal safety features including Over-Voltage Protection (OVP), Over-Current Protection (OCP), Short-Circuit Protection (SCP) and Over-Temperature Protection (OTP). ■

## Echelon Introduces BACnet Gateway for Echelon LumInsight™ Desktop

Echelon Corporation, a leading independent control networking company for the Industrial Internet of Things (IIoT), announced new capabilities for intelligently managing lighting, using popular Building Management Systems (BMS) via its new LumInsight BACnet gateway. Part of the Lumewave by Echelon™

solution, LumInsight Desktop software offers a BACnet gateway to address the growing desire of enterprise facilities managers to control, manage, and monitor all their lighting devices and sensors, indoor and outdoor, in an industry standard platform as well as support multiple building operations from a single dashboard.



Echelon's LumInsight BACnet gateway expands the opportunities to converge places like parking areas with the building ecosystem by integrating indoor and outdoor lighting onto one master building dashboard

"BMS integration is the next evolution of the built environment solution," said Jose M. Varona, Associate Director of Energy Management Systems, University of Miami. "The integration is where we gain not only a global view of the indoor and outdoor deployment, but benefit from maintenance cost reductions, faster response time for support issues, and access to a wider range of emerging smart applications."

Better energy and utilization efficiency, real-time consolidated performance data, and lower costs are key factors driving building owners to seek a system-wide integrated control solution. By using the Echelon BACnet gateway, multiple facility networks - from lighting to sensors - can converge into a single, unified energy management system for insight into and control of building and lighting systems. Then, as new requirements for advanced applications are needed, such as space utilization and security monitoring, or the

need to respond to emerging opportunities generated from Internet of Things (IoT), building proprietors will be ready to expand with the BACnet LumInsight Desktop solution.

"Converging lighting systems with building controls reduces cost and improves facility management, safety and customer satisfaction, which is an end-goal of today's facility leaders," said Dan DeLong, President, Architectural Lighting Designs, Inc. "When the facility management of a building, parking garage and exterior lighting converge into one system, facility managers have limitless control, and for the first time, can be proactive to any changes that may arise. Echelon's new BACnet gateway demonstrates how bridging building and lighting systems creates a more functional and overall smarter system. From what I've seen so far in this pilot, Echelon has created a solid solution based on its deep building automation knowledge and controls experience." ■



瑞豐光電

# 2216 series

Future optimal for light bar!



With smaller size;  
more flexible application;  
better color consistency;  
thinner thickness;  
simpler technology and lower cost.



SHENZHEN REFOND OPTOELECTRONICS CO.,LTD.

Add: Building #1, 10th Industrial Zone, Tian Liao Community, Gong Ming Area,  
Guang Ming New District, SHENZHEN, CHINA  
TEL: +86-755-66839118 FAX: +86-755-66839300 E-mail: konny@refond.com

Stock Code : 300241.SZ  
www.refond.com



## PolyOne UltraTuf™ LED Light-Diffusing Sheet

PolyOne announced the launch of UltraTuf™ LED, a premium light diffusing sheet that combines excellent light transmission and diffusion properties with toughness, chemical resistance and improved design flexibility. UltraTuf LED sheet is made using BPA-free Eastman Spectar™ Stratus copolyester, which has received UL Greenguard Certification for Indoor Air Quality (Spectar is a registered trademark of Eastman Chemical Company / Greenguard Certification Program is owned by UL Environment).

### Highlights:

- Outstanding diffusion
- Excellent light transmission
- Durability
- Design flexibility
- Chemical resistance
- Greenguard Indoor Air Quality Certified

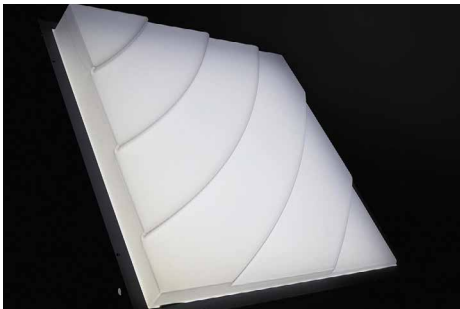

PolyOne's UltraTuf LED sheet is easy to fabricate, enabling ample creativity in design

UltraTuf™ LED sheet, manufactured using Eastman Spectar™ Stratus copolyester, is specially designed with optical properties that allow high levels of light transmission while effectively hiding hot spots in LED applications. This durable sheet also provides an excellent balance between toughness and ease of fabrication. It withstands the rigors of shipping and installation, yet allows creativity in design and forming.

"We developed new UltraTuf LED sheet with the ability to transmit up to 91% of light while still effectively diffusing the light across the lens," said Kendall Justiniano, marketing director, Designed Structures and Solutions at PolyOne. "And we also harnessed the design flexibility and exceptional durability inherent in the base material to deliver a complete solution to LED lighting system designers."

Because it offers deep draw thermoforming capabilities, UltraTuf LED sheet can be used to create visually stunning designs that allow OEMs to differentiate their lighting systems. It also has superior durability, withstanding direct impact in shipping or use of up to 15 times that of most traditional light diffuser materials for simpler handling and longer installed life. Good chemical resistance makes UltraTuf LED suitable for demanding environments, and ease of processing helps to improve operational efficiency during manufacture. ■

## Wacker Presents New Gap Filler for Electronics Applications

Wacker, the Munich-based chemical company, showcased a new heat-conducting silicone-based gap filler material for the electronics industry at the Power Conversion and Intelligent Motion electronics tradeshow PCIM Europe. Available under the tradename SEMICOSIL® 961 TC, the silicone rubber is ideal as an interface material for thermally connecting electronic circuits, ensuring effective heat management. The product is characterized by good flow and processing properties. Furthermore, wear of the mixing and metering equipment used in its application is low.

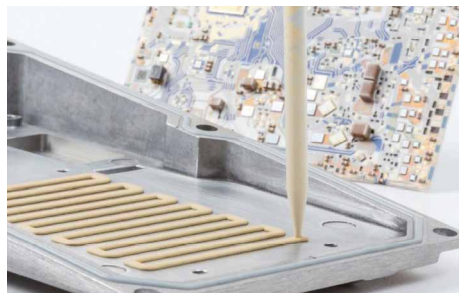

The heat-conducting SEMICOSIL® 961 TC silicone filler from Wacker is applied directly to the heat sink. Once the electrical circuit is pressed on, the gap filler cures to form a soft, cushioning silicone layer that optimally transfers heat to the heat sink

With the new silicone gap filler material, Wacker is expanding its portfolio of thermal interface materials. SEMICOSIL® 961 TC is a highly filled, two-part silicone rubber that cures at room temperature via a platinum-catalyzed addition reaction to form a soft silicone elastomer with a tacky surface. The cured rubber achieves a thermal conductivity of two watts per meter kelvin and, at the same time, is electrically insulating.

Before it cures, SEMICOSIL® 961 TC is a non-sag material. However, its viscosity decreases with increased shearing, for example during mixing and metering. Its shear-thinning property is adjusted so that the silicone rubber can easily be fed by machine and applied as a bead. Processors can achieve a high metering rate and very high dosing accuracy.

SEMICOSIL® 961 TC ensures optimum heat transfer from the electrical circuit to a heat sink. In practice, the gap filler is first applied to the heat sink. The circuit board is then pressed on or fitted by means of a vacuum process. During compression, a continuous film forms that conforms snugly to the surfaces of the two joining parts. In this way, surface irregularities and tolerances can be evened out perfectly. Furthermore, the film maximizes the contact area and thus promotes heat transfer.

The film cures to form a silicone layer between the joining parts. Thanks to its soft consistency, it ensures a reliable, tight fit even if there are frequent temperature changes and vibrations. In addition, the new silicone gap filler can be used over a wide temperature range. Its properties remain unchanged between -45 and +180 degrees Celsius. High thermal and thermal-shock resistance and the ability to absorb vibrations are important for applications in automotive electronics and electromobility, for example.

SEMICOSIL® 961 TC is a two-component system. Despite its high filler loading, it has a comparatively minor abrasive effect on the mixing and metering equipment used to apply it. This means that there is less abrasive damage to feed pumps, for example, than is usually the case with highly filled silicone rubber. Consequently, significantly longer service lives of mixing and metering equipment and major cost advantages in processing are possible.

The new gap filler contains hardly any volatile components. In terms of fire-safety properties, tests show that the silicone product meets the specifications for classification V-0 as per UL 94 of Underwriters Laboratories. SEMICOSIL® 961 TC is available in both Euro cartridges and 30-kilogram pails. ■

**NEW CREE® XLAMP® LEDs CAN:**

*IMPROVE RELIABILITY ::*

*REDUCE SYSTEM COST ::*

*REDEFINE LED LIGHTING ::*

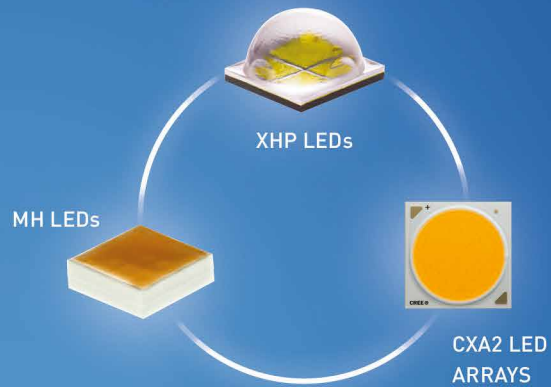

# GAME CHANGING IS GREAT. BOTTOM LINE CHANGING IS BETTER.

You can't change your bottom line by using the same LEDs that everyone else is using. Cree's Extreme High Power (XHP) LEDs deliver double the lumen output at high operating temperatures, while our MH LEDs combine the system advantages of our best arrays with the manufacturing ease of a discrete. And our CXA2 LED arrays are packed with lumens to offer system cost savings up to 60%.

**CREE** 

See how higher power equals lower cost.  
[cree.com/xhp](http://cree.com/xhp)

The new way to a better LED array.  
[cree.com/mh](http://cree.com/mh)

Even more lumens for savings up to 60%.  
[cree.com/cxa2](http://cree.com/cxa2)

## MD-SIG Launches LEDset Specifications for Interoperable LED Drivers and Modules

The Module-Driver Interface Special Interest Group (MD-SIG), a lighting-industry consortium, has published its LEDset specifications. LEDset provides the lighting market with a standardized, multi-vendor, electrical interface for LED systems, which simplifies the process of matching LED modules with suitable drivers.

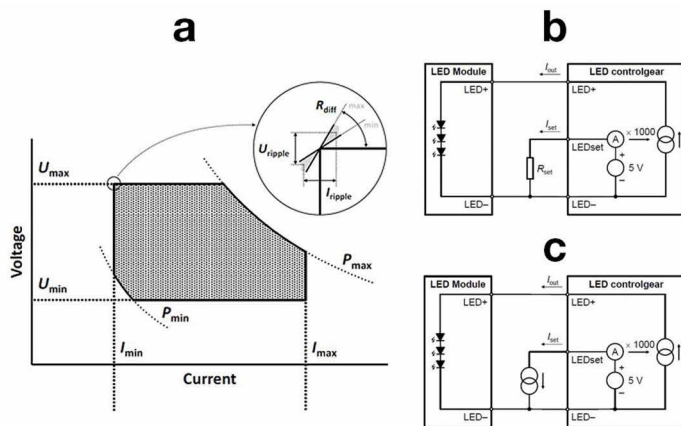

Some MD-SIG specification examples: (a) output range of a window driver (shaded), (b) a setting resistor  $R_{set}$  plus an arbitrary LED module, (c) a current source plus an arbitrary LED module

MD-SIG is an open, global consortium consisting of leading lighting and LED driver manufacturers: BAG electronics, BJB, Helvar, Osram, Panasonic/Vossloh-Schwabe, Philips Lighting, TCI and Zumtobel/Tridonic.

Today, there are many different options on the market for communication and power transmission between an LED control gear (driver) and one or more LED modules. This leads to increased complexity, availability issues and risk of incompatibility for fixture OEMs.

MD-SIG was formed with the aim of introducing a standardized electrical interface between LED control gear and LED modules. This "missing link" is an essential feature of a mature components business for solid-state lighting.

The LEDset interface created by MD-SIG meets the growing demand in the market for harmonization, and makes it much easier to match LED modules with configurable LED drivers.

### Specification Details:

MD-SIG has published two specification documents – the "LEDset Power Interface Specification" and the "LEDset1 Information Interface Specification" – which can also be downloaded from the MD-SIG website ([ledset-standard.org/specifications](http://ledset-standard.org/specifications)).

The LEDset Power Interface Specification describes the data-sheet information that should be provided for LED modules and LED drivers, in terms of the output current, voltage and power ranges.

With this standardized approach, luminaire makers can identify interoperable components without the risk of inaccurate matching

PEOPLE SEE LIGHT ...WE MEASURE IT

Spectral light measurement solutions for lab, production and field applications in accordance with CIE S 025/E:2015 and IES LM-79-08

[www.gloptic.com](http://www.gloptic.com)

2216 lumen  
842 lux  
x 0.376 y 0.374  
4097 kelvin

**GLOPTIC**  
Light measurement solutions

**LED SYMPOSIUM**  
professional + EXPO  
Sept 20<sup>th</sup> - 22<sup>nd</sup> | Booth #C5

due to poorly-defined specification parameters (e.g. temperature drift, forward-voltage tolerances and current-modulation effects). The specification also describes the testing conditions and measurement methods that should be used to verify the provided information.

The LEDset1 Information Interface Specification describes a setting method that uses a resistor to configure the output current of a window driver. The resistor is attached to the driver in the production line of the luminaire manufacturer. The LEDset1 interface can alternatively be used to automatically adapt the output current of a window driver according to an integrated coding resistor on the LED module(s). It also supports thermal de-rating of LED modules with integrated temperature sensors. Digital configuration methods are under consideration for future specifications.

The MD-SIG specifications are complementary to those developed by the Zhaga Consortium, another lighting-industry organization that is independent from MD-SIG. Zhaga defines various interfaces between LED components and LED luminaires, but it does not address the electrical interface between LED modules and drivers. Instead, several Zhaga Books already contain references to the new MD-SIG specifications. ■

### About MD-SIG:

The Module-Driver Interface Special Interest Group (MD-SIG) is a global lighting industry consortium open for all interested parties, aiming to introduce a standardized multi-vendor electrical interface. The smart electrical interface LEDset between LED control gear and modules is the missing link essential to the maturity of SSL components business. The LEDset interface created by the consortium allows communication and power transmission between an LED control gear and one or more LED modules. Today, many different options are available on the market, leading to increased complexity and shortened availability for fixture OEMs. MD-SIG meets the growing demand in the market for harmonization by introducing a standardized multi-vendor electrical interface for LED systems. Thus matching LED modules with LED window drivers becomes much easier.

## Perovskite Phosphor Provides High Quality White Light and Boosts VLC

Mark Peplow recently reported on the Chemical & Engineering News website about the latest encouraging research results from a research team from CEMSE and KAUST. The researchers found that a combination of solution-processed CsPbBr<sub>3</sub> perovskite nanocrystals (NCs) with a conventional red phosphor produces high quality white light when pumped with a blue LED or laser. Furthermore excited-state lifetime is short enough to provide record-breaking high bandwidth for visible light communication (VLC), aka LiFi.

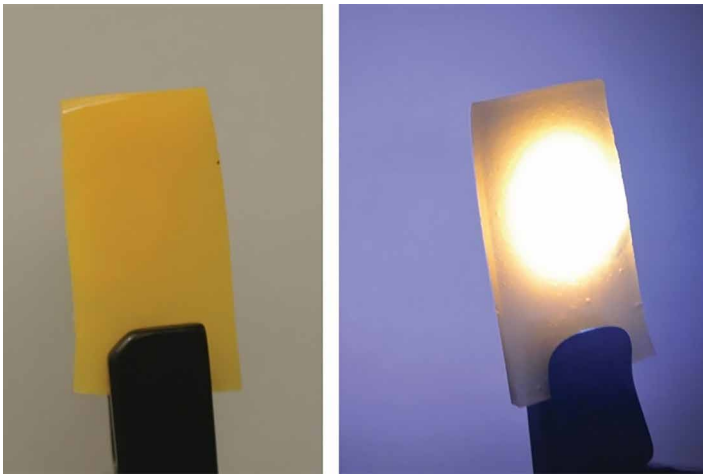

**A green-emitting perovskite nanocrystal phosphor mixed with a red-emitting nitride phosphor looks yellow under ambient light (left). When excited by blue laser light, the phosphor combination produces white light (right) - (Credit: Osman Bakr)**

Light-emitting diodes (LEDs) are increasingly used to illuminate homes and offices; the same lights could soon transmit data to your computer or smartphone in photon pulses so fast the eye can't see them. But this form of visible light communication faces two key challenges: The light must flicker fast enough to carry sizeable amounts of data; and at the same time it should provide the warm, balanced color tones needed for pleasant ambient lighting.

Nanocrystals of cesium lead bromide (CsPbBr<sub>3</sub>) could help to solve both problems, according to a team led by Boon S. Ooi and Osman M. Bakr at King Abdullah University of Science & Technology (KAUST). They have found that LEDs coated with the material can reach high data transmission rates of 2 gigabits per second, comparable to the fastest Wi-Fi, while producing a quality of light that matches commercial white-light LEDs (ACS Photonics 2016, DOI: 10.1021/acsphotonics.6b00187).

Visible light communication, sometimes called Li-Fi, is already finding real-world applications. Last year, for example, Dutch company Phillips installed a smart LED system in a French supermarket that uses Li-Fi to transmit discount offers to shoppers' cellphones, based on their location in the store. If data rates could be increased significantly, Li-Fi might add much-needed capacity to congested Wi-Fi networks that rely on radio waves.

And since the smart LEDs are doing double duty, by providing both lighting and communication, they offer an economical solution, says Bakr. Ooi adds that these systems do not even need a direct line of sight between LED and computer: "As long as your device can see light, you can detect a signal," he says.

White-light LEDs typically contain a blue LED coated with phosphors that turn some of the light into green and red. But most phosphors take too long to recover between excitation and emission, pulsing no more than a few million times per second. Last year, other researchers showed that polymer semiconductors could reach more than 200 MHz (ACS Photonics 2015, DOI: 10.1021/ph500451y).

The KAUST team instead turned to CsPbBr<sub>3</sub>, part of a family of materials known as perovskites that have become the darling of the photovoltaic research community. Perovskite solar cells have seen remarkable efficiency gains over the past seven years, and the materials are cheap and relatively easy to prepare in solution.

The team created nanocrystals of the perovskite, roughly 8 nm across, and found that their green emission faded in just seven nanoseconds. This allowed them to pulse reliably at almost 500 MHz, setting what the researchers believe is a new record for LED phosphors. "It is an extremely impressive and important achievement," says Ted Sargent of the University of Toronto, who works on optoelectronic materials and has collaborated with the KAUST group in the past.

The rapid response is partly due to the size of the crystals, Bakr explains. When blue light excites an electron in the material, it forms an electron-hole pair called an exciton. The confines of the tiny crystal change the exciton's energy levels, making the electron more likely to recombine with its hole and emit a photon.

When the researchers teamed the perovskite phosphor with a commercial red-emitting phosphor and a blue gallium nitride LED, the device produced a warm white light with a color rendering index of 89, as good as white LEDs already on the market (natural sunlight itself is rated at 100). "This quality makes this material ideal for low-power indoor illumination," Sargent says.

Jakoah Brgoch of the University of Houston, who develops novel phosphors for LED lighting, says that it is relatively easy to fine-tune the chemistry of perovskites by substituting different halides or metal ions. "That means there's a lot of potential to improve these properties," he says. ■

### Original news source:

<http://cen.acs.org/articles/94/web/2016/06/Perovskite-phosphor-boosts-visible-light.html>

### Original research publication:

DOI: 10.1021/acsphotonics.6b00187

<http://pubs.acs.org/doi/abs/10.1021/acsphotonics.6b00187>

<http://pubs.acs.org/doi/ipdf/10.1021/acsphotonics.6b00187>

<http://pubs.acs.org/doi/full/10.1021/acsphotonics.6b00187>

## New Phosphor Promises Cheaper and More Efficient Next-Generation LED Lighting

Researchers from KU Leuven (Belgium), the University of Strasbourg, and CNRS have discovered a new phosphor that could make next-generation fluorescent and LED lighting even cheaper and more efficient. The team used highly luminescent clusters of silver atoms and the porous framework of minerals known as zeolites.



A new phosphor could make next-generation fluorescent and LED lighting even cheaper and more efficient

Silver clusters consist of just a few silver atoms and have remarkable optical properties. However, current applications are limited, because the clusters tend to aggregate into larger particles, thus losing the interesting optical properties.

Professor Hofkens and his team from the Molecular Imaging and Photonics Unit have now found a way to keep the silver clusters apart by inserting them into the porous framework of zeolites. The result: stable silver clusters that maintain their unique optical properties.

Zeolites are minerals that are either found in nature or produced synthetically on an industrial scale. The minerals have a very rigid and well-defined framework of small molecular-sized channels, pores, and cages. They're commonly used in domestic and industrial applications such as washing detergent and water treatment.

Professor Maarten Roelfaers from the Centre for Surface Chemistry and Catalysis explains: "Zeolites contain sodium or potassium ions. We used ion exchange to replace these ions with silver ions. To obtain the clusters we wanted, we heated up the zeolites with the silver ions, so that the silver ions self-assembled into clusters."

In collaboration with Professor Peter Lievens's Laboratory for Solid State Physics and Magnetism, the researchers examined the properties of these heat-treated 'silver zeolites'. Using advanced techniques, they found that the structural, electronic, and optical properties of the zeolites were strongly influenced by the silver clusters. That's how they discovered that the shape of the silver clusters is essential to obtain the right fluorescence properties.

Professor Johan Hofkens explains: "Clusters of silver atoms can assemble into different shapes, including a line or a pyramid.

This pyramid shape is what we need to obtain the best fluorescence properties. Heating up the silver ions in the zeolite framework makes them adopt this shape. Because they are 'trapped', as it were, in the cages of the zeolites, they can only form a pyramid with up to four silver atoms. That is exactly the shape and size in which the silver cluster emits the largest amount of fluorescent light, with an efficiency close to 100%."

These findings have great potential for the development of next-generation fluorescent and LED lighting and for biological imaging. After all, the new phosphors not only emit a large amount of light, they are also cheap to produce. ■

### Acknowledgements:

This study was funded by the European Union: EU FP7-NMP-2012 SACS (Self-Assembly in Confined Space; GA-310651).

### References:

Click here to read the study in Nature Materials (doi: 10.1038/nmat4652). Copies can also be obtained from the authors.

## Research on OLEDs with Ultrathin Emissive Layers and a Spacer-Free Structure

Since C.W. Tang demonstrated the first organic light-emitting diodes (OLEDs) based on a double-layer structure of organic materials in 1987, flat-panel displays and lighting applications based on OLED technology have grown dramatically because of their attractive features such as ultra-thin structure, light-weight and flexibility. To achieve a desirable OLED performance, a host-dopant system is adopted. This not only leads to an increase in material cost and device processing time, but also makes it difficult to control dopant concentration accurately. Therefore, OLEDs with dopant-free and ultrathin emissive layers (UEMLs) have aroused much attention. Shengfan Wu, Sihua Li, Qi Sun, Chenchao Huang & Man-Keung Fung recently published the results of their research on such ultrathin emissive layers (UEMLs) of phosphorescent materials for OLED applications.

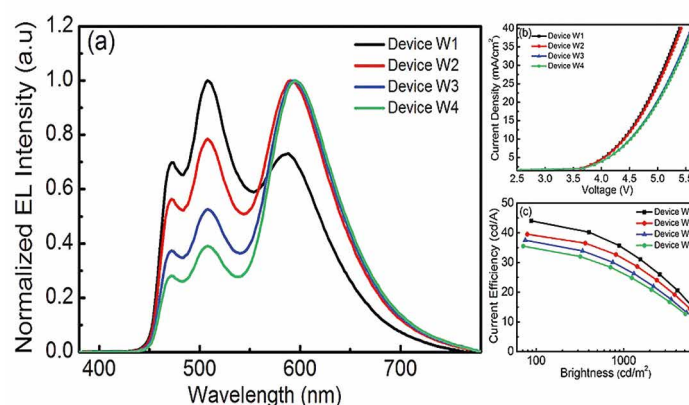

(a) EL spectra of the devices based on different thicknesses of Ir(MDQ)2(acac) varying from 0.02 nm (W1), 0.04 nm (W2), 0.06 nm (W3) and 0.08 nm (W4), (b) J-V curves, and (c) Current efficiency–brightness characteristics of the devices



**Abstract:**

Ultrathin emissive layers (UEMLs) of phosphorescent materials with a layer thickness of less than 0.3 nm were introduced for high-efficiency organic light-emitting diodes (OLEDs). All the UEMLs for white OLEDs can be prepared without the use of interlayers or spacers. Compared with devices fabricated with interlayers inserted in-between the UEMLs, our spacer-free structure not only significantly improves device efficiency, but also simplifies the fabrication process, thus it has a great potential in lowering the cost of OLED panels. In addition, its spacer-free structure decreases the number of interfaces which often introduce unnecessary energy barriers in these devices. In the present work, UEMLs of red, green and blue-emitting phosphorescent materials and yellow and blue phosphorescent emitters are utilized for the demonstration of spacer-free white OLEDs. Upon optimization of the device structure, we demonstrated spacer-free and simple-structured white-emitting OLEDs with a good device performance. The current and power efficiencies of our white-emitting devices are as high as 56.0 cd/A and 55.5 lm/W, respectively. These efficiencies are the highest ever reported for OLEDs fabricated with the UEML approach.

**Approach:**

In their paper, the authors first discuss high-efficiency red, green and blue-emitting OLEDs based on phosphorescent UEMLs, the efficiencies of which are comparable or even better than those fabricated using conventional host-guest systems. Simple and high-efficiency white OLEDs were also fabricated using phosphorescent UEMLs consisting of red, green and blue emitters as well as orange and blue emitting materials, without any interlayer. The color balance was actively tuned by the thickness of the UEMLs in a much simpler and more controllable way. Therefore, UEMLs with spacer-free

structures have a great potential in achieving power-efficient white OLEDs.

In order to express the promising potential of UEMLs, several green-emitting phosphorescent OLEDs (PHOLEDs) with different conventional host-guest systems were fabricated for comparison. It is remarkable that the performance of green OLED prepared by the UEML approach surpasses those fabricated by the conventional host-guest systems.

In view of the above remarkable results, two-color PHOLEDs based on green and blue UEMLs were fabricated. For those multi-color OLEDs currently prepared with the UEML approach, an interlayer is usually inserted in between two emissive layers. It can be speculated that the second UEML may fill the unoccupied sites randomly as an interstitial doping. Therefore, interlayer or spacer may not be necessary in multi-color UEML based devices. Consequently, simple and spacer-free UEML-based OLED devices were fabricated. Once the thickness of the phosphorescent UEMLs has been optimized, three-color white OLEDs based on red, green and blue UEMLs were explored.

**Conclusion:**

UEML based OLEDs show an excellent device performance. The red, green and blue OLEDs with UEML structures exhibit a current efficiency of 29.9 cd/A, 79.5 cd/A and 39.0 cd/A, respectively, which are comparable or even better than conventional OLEDs which use host-guest system. High-efficiency UEML based two-color and three-color white OLEDs have also been fabricated. It has been successfully demonstrated that interlayers or spacers are not needed, and the device structures of white OLEDs are significantly simplified. For three-color white OLEDs, current and power efficiencies of 39.5 cd/A and 38.9 lm/W could be obtained with CIE (x, y)

of (0.43, 0.44). If the white OLED has a warmer emission (two-color white), the current and power efficiencies could be increased to 56.0 cd/A and 55.5 lm/W, respectively. The device efficiencies of our two-color and three-color white OLEDs demonstrated here are so far the highest ever reported for devices with ultrathin emitting-layer structures. Therefore, OLEDs fabricated with UEMLs are very cost-effective and promising. ■

**References:**

This article is a short summary of the original paper. The original paper is published at <http://www.nature.com/articles/srep25821>

**Author information:**

Institute of Functional Nano & Soft Materials (FUNSOM), Jiangsu Key Laboratory for Carbon-Based Functional Materials & Devices, Soochow University, 199 Ren'ai Road, Suzhou, 215123, Jiangsu, PR China

Shengfan Wu, Sihua Li, Qi Sun, Chenchao Huang & Man-Keung Fung:

S.W. conceived the idea and designed the experiments. S.L. fabricated the devices and measured the device performance. Q.S. and C.H. participated in structure designing. M.F. analyzed most of the data and revised the manuscript. All authors reviewed the manuscript and contributed to this work.

**License Information:**

This work is licensed under a Creative Commons Attribution 4.0 International License. The images or other third party material in this article are included in the article's Creative Commons license, unless indicated otherwise in the credit line; if the material is not included under the Creative Commons license, users will need to obtain permission from the license holder to reproduce the material. To view a copy of this license, visit <http://creativecommons.org/licenses/by/4.0/>

## WEBINARS



### Faster to Light with Simpler Design: A New Multimode Flyback LED Solution

Infineon's LED lighting solutions will be presented with a focus on the new IRS2982S IC - The right solution for mid-range to high-end LED drivers.

## Register to view the webinar!

[www.led-professional.com/Infineon-Webinar-0316](http://www.led-professional.com/Infineon-Webinar-0316)



# Photometry Radiometry

The science of light measurement



## Handheld light meter & optometer ILT 2400

- 8 Decade dynamic range of optical analysis
- Internal memory
- 4.3" touch screen
- Meter & sensors with NIST traceable ISO17025 accredited calibration
- DataLight II software for Windows 7, 8 and 10

## Illuminance spectrophotometer ILT 350

- Measures Lux, CCT, CRI and CIE1931 color spectrum
- Measurement range from 380 to 780 nm
- NIST traceable ISO17025 accredited calibration
- Data storage



lot-qd.com

Visit us at the LPS 2016 in Bregenz, booth A10

## LUGER RESEARCH Organizes electronica SSL Forum 2016

The Electronica SSL Forum will communicate an outline of technologies applied in Solid-State-Lighting systems. Selected state-of-the-art samples will be displayed and relations and obstructions between utilized technologies will be presented. The forum addresses electronic design engineers, system designers, project managers, production engineers and supply chain managers involved in SSL product development.

Developing efficient, optimized LED-systems requires usage of several technologies that have to correlate with each other. On the one hand, technologies that generate light with high efficiency and high light quality in the semiconductor are needed and on the other hand, suitable power electronics and good thermal management for cooling the LED are required. In the course of the forum these technologies and their interdependencies will be discussed. In respect to the current state of technology, LED lighting technologies will be focused on. In addition, OLED and its future prospects will be discussed in detail. A separate lecture will address lighting control of SSL systems, smart lighting and the Internet of Things (IoT). The mainly technical content of the lectures will be rounded off by an observation of the SSL market and LED applications.

The Solid State Lighting Forum will be comprised of a keynote and six lectures. It will end with a tech panel discussion on trends and future perspectives of SSL. ■

### Electronica 2016 Forum Program Overview - Nov. 8<sup>th</sup> - 11<sup>th</sup>, 2016

Forum	Location		
<b>Automotive Forum</b>	Hall A6	<b>Electronica Forum</b>	Hall A3
<ul style="list-style-type: none"> <li>• Consumer Components in automotive</li> <li>• Applications Security in automotive</li> <li>• Products functional safety ISO 26262</li> <li>• Connectivity</li> <li>• Automotive Lighting</li> <li>• Exterior and Interior Technologies for Semi-/ Autonomous Driving</li> </ul>		<ul style="list-style-type: none"> <li>• CEO Round Table: Connected Worlds – Safe and secure!</li> <li>• Sector forums:               <ul style="list-style-type: none"> <li>◦ Cyber-Security</li> <li>◦ Industrial IoT</li> <li>◦ Solid State Lighting</li> <li>◦ Wearables and Healthcare</li> </ul> </li> <li>• Student Day</li> </ul>	
<b>Embedded Forum</b>	Hall A6	<b>PCB &amp; Components Marketplace</b>	Hall A2
<ul style="list-style-type: none"> <li>• Internet of Things: Smart factory, smart energy, smart buildings, etc.</li> <li>• Security and IoT: Challenges and solutions</li> <li>• Technical trends with microcontrollers and microprocessors</li> <li>• Motor control solutions</li> <li>• Tools and software for embedded systems</li> <li>• Embedded computing: Boards, modules and more</li> <li>• Technical trends with analog and power</li> <li>• Embedded solutions for industrial and automation</li> </ul>			

**LpS 2016**  
**LED SYMPOSIUM**  
professional +EXPO

POST WITH   
**#LEDpro**  
SOCIAL MEDIA WALL

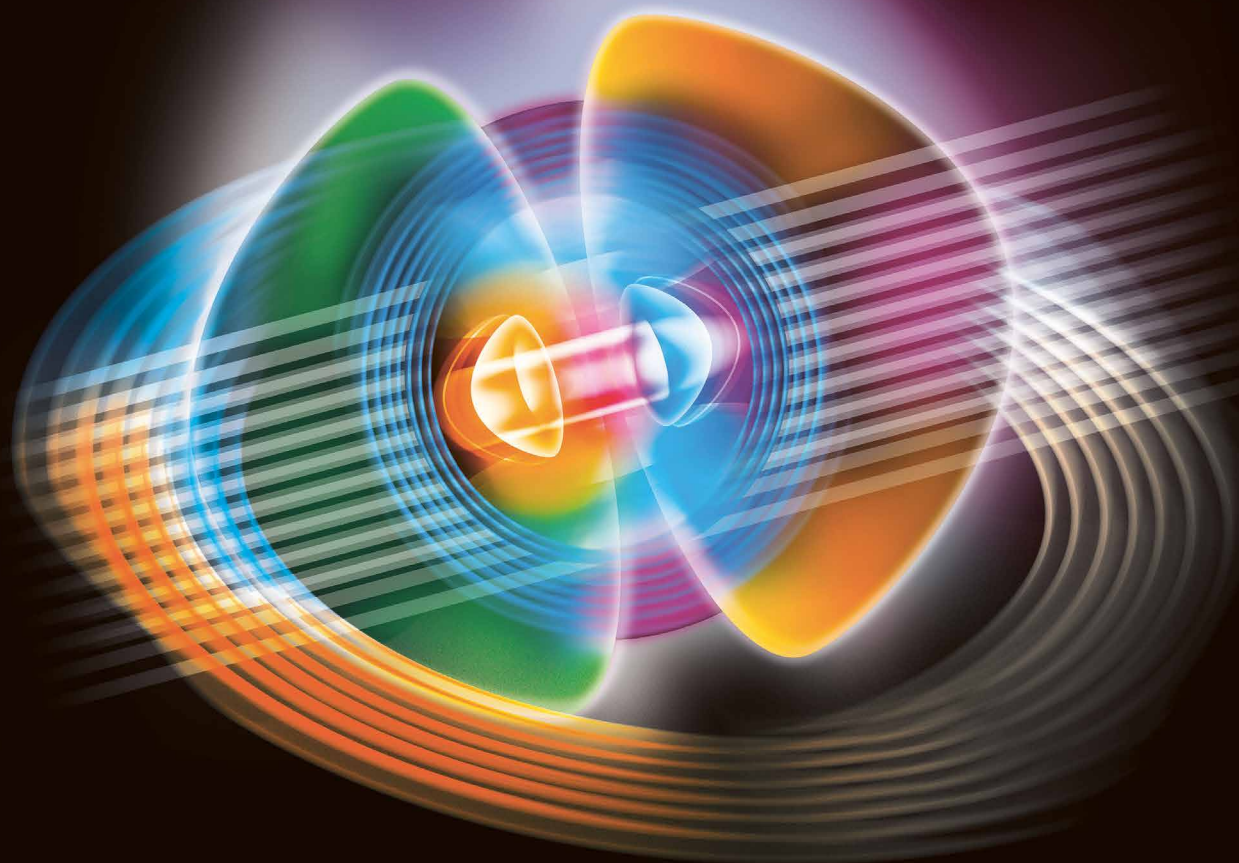

## 6<sup>TH</sup> LED professional Symposium +Expo

Smart Technologies for Lighting Innovations

Sept 20<sup>th</sup> -22<sup>nd</sup> 2016 | Bregenz | Austria

[www.lps2016.com](http://www.lps2016.com)





# LED professional Symposium +Expo 2016

The LpS 2016 is Europe's foremost solid-state lighting technology event for experts in industry, entrepreneurs, engineers, technicians and scientific researchers in the fields of general, industrial and architectural lighting.

The event covers the building blocks for smart lighting designs of luminaires, lamps, controls, modules and components. It focuses on trends and technologies for future lighting solutions incorporating human centric lighting, Internet of Things, connected lighting and smart controls. The combination of a three-day multi-disciplinary symposium, workshops, international exhibition and networking possibilities is a perfect platform to explore sophisticated semiconductor lighting in the fields of general, automotive and special lighting applications.



## International Conference on Lighting Trends & Technologies

- Latest insights from research and industry leaders
- Nobel prize laureate Prof. Shuji Nakamura
- 100+ lectures in 4 conference tracks
- 1500+ professionals from more than 50 countries

## International Exhibition for Lighting Technologies & Applications

- State-of-the art showcases for R&D and design engineers
- Cutting-edge products, equipment and services
- Highly-focused B2B sourcing and collaboration platform
- 100+ international exhibitors including the top leaders

## Lectures from Renowned Organizations

EU Commission, LightingEurope, Zhaga, EPIC, IBM, NXP, Infineon, Silvair, DALI, Bartenbach, GE, Zumtobel, UniBright, Glamox, Nichia, Lumileds, Cree, Osram, Fraunhofer, Yole, Holst Center, Joanneum, CSEM

## Interactive Workshops & Forums

- Tunable lighting workshop by HI-LED
- Design-meets-technology forum by APIL
- Horticultural lighting workshop by EPIC
- ISA and Photonics cluster forums
- IoT & AI workshop by Jakajima

## Innovation Platforms

- Technical innovations presented by start-up innovators
- Light-Art-Designs by lighting designers and students
- Product launches presented by industry leaders

## Social Networking Opportunities

- Opening ceremony and expo reception
- Get-Together boat cruise on Lake Constance
- International press conference with more than 25 media partners

# Workshops

Saal Bodensee | SEPT 21, 14.00-18.00

## Hi-LED Intelligent Lighting Workshop

Spectrally and tunable LED and OLED lighting - This workshop, organized by the EU FP7 HI-LED project, aims to attract the participation of lighting professionals, photonics researchers, lighting manufacturers, end users from European museums, horticulture growers, health care centers, ICT research organizations as well as analysts and investors interested in smart lighting sector.

- Human centric lighting
- Horticultural lighting
- Art work and museum lighting

Saal Panorama | SEPT 22, 08.30-14.00

## Internet of Things (IoT) & Artificial Intelligence Workshop

With Jakajima, organizer of the annual IoT Event in Eindhoven and Matchmaker for Innovators.

- IoT and machine learning (AI & IoT)
- Design of IoT & AI solutions
- New business models

Saal Bodensee | SEPT 22, 08.30-14.00

## EPIC Horticultural Lighting Workshop

EPIC is the industry association that promotes the sustainable development of organisations working in the field of photonics in Europe.

- Market and technology overview of horticultural lighting
- Latest research, case studies and key drivers of horticultural lighting
- Practical experiences and technology outlook

Seefoyer | SEPT 22, 12.30-14.00

## Solid-State Lighting Measurement Workshop

Solid-state lighting measurements from basics to recent developments by Instrument Systems GmbH and TÜV SÜD.

- New standard CIE S025
- Measurements with Goniophotometers and Integrating Spheres
- Regulation (EU) 1428/2015
- Application insights to SSL measurements

# Forums

Saal Bodensee | SEPT 20, 14.00-18.30

## ISA Lighting Forum

Forum with the leading Chinese based SSL organization. ISA members representing 70% of the global SSL industry output.

- ISA industry report 2016 - emerging markets and their developments
- Innovative application of LEDs in different fields and beyond lighting
- Introduction of ISA and its activities
- SSL development in ASIA and the cooperation model
- LEDs insure & LED performance insurance

Saal Bodensee | SEPT 21, 08.30-13.00

## Design meets Technology Forum

Design forum with APIL, the leading association of Italian independent lighting designers.

- Understanding design and technology requirements
- Key and common design criteria in applications
- Practical examples, cornerstones and lessons learned

Saal Panorama | SEPT 20, 14:00-18.30

## Photonics Cluster Forum

Photonics Clusters presenting and discussing new approaches in light sources.

- Overview of alternative light sources
- Technologies and market potentials
- Laser light sources

# Social & Special Events

Opening Grosser Saal | SEPT 20, 10.00-10.30

Scientific Award Ceremony Grosser Saal | SEPT 20, 10.00-10.30

Keynotes Grosser Saal | SEPT 20, 10.30-12.00

Exhibition Reception Werkstattbühne | SEPT 20, 12.00-12.30

Press-Conference Parkstudio | SEPT 20, 18.30-19.00

Get-Together Boat Cruise Lake Constance | SEPT 21, 18.30-23.00



# EVENT OVERVIEW

## DAY 1 STRATEGY

SEPT. 20<sup>TH</sup>  
TUESDAY

### Opening

- 10.00 - 10.30** **Opening & Scientific Award Ceremony** | Grosser Saal
- 10.30 - 12.00** **Keynotes** | Grosser Saal
- 12.00 - 13.00** **Exhibition Reception / Opening** | Werkstattbühne & Seitenbühne

### Parallel Sessions

- 14.00 - 18.30** **Lighting Trends** | Seestudio
- 14.00 - 18.30** **Lighting Intelligence** | Seefoyer
- 14.00 - 18.30** **Lighting Design** | Propter Homines

### Forums

- 14.00 - 18.30** **ISA Forum** | Saal Bodensee
- 14.00 - 18.30** **Photonics Cluster Forum** | Saal Panorama

### Evening Event

- 18.30 - 19.00** **Press Conference** | Parkstudio

## DAY 2 TECHNOLOGY & DESIGN

SEPT. 21<sup>ST</sup>  
WEDNESDAY

### Parallel Sessions

- 09.00 - 18.00** **Light Sources** | Seestudio
- 08.30 - 18.00** **Smart Lighting Connectivity** | Seefoyer
- 08.30 - 18.00** **Engineering** | Propter Homines

### Forum

- 08.30 - 13.00** **Design meets Technology Forum** | Saal Bodensee

### Workshop

- 14.00 - 18.00** **Workshop Hi-LED** | Saal Bodensee

### Evening Event

- 18.30 - 23.00** **Get-Together Evening** | Boat trip on Lake Constance

## DAY 3 SOLUTION

SEPT. 22<sup>ND</sup>  
THURSDAY

### Parallel Sessions

- 09.00 - 14.00** **System Quality** | Seestudio
- 08.30 - 10.30** **System Qualification** | Seefoyer
- 08.30 - 14.00** **Applications** | Propter Homines

### Workshops

- 08.30 - 14.00** **Workshop EPIC** | Saal Bodensee
- 08.30 - 14.00** **Internet of Things (IoT) & Artificial Intelligence Workshop** | Saal Panorama
- 12.30 - 14.00** **Solid State Lighting Measurement** | Seefoyer

LOS 2016 - PROGRAM

# STRATEGY DAY SEPT TUE 20<sup>TH</sup>

Time	Lighting Trends	Lighting Intelligence	Lighting Design	Forums
10.00	Grosser Saal <b>Opening &amp; Scientific Award Ceremony</b>			
10.30	Keynote   Grosser Saal <b>Solid-State Lighting in the Framework of Horizon 2020</b> <i>Dr. Ronan Burgess European Commission, Belgium</i>			
11.00	Keynote   Grosser Saal <b>LightingEurope Roadmap 2025: The Smart Lighting Strategy</b> <i>Diederik de Stoppelaar LightingEurope, The Netherlands</i>			
11.30	Keynote   Grosser Saal <b>The Future of LED and LD Lighting Technologies</b> <i>Prof. Shuji Nakamura University of California, USA</i>			
12.00	Werkstattbühne & Seitenbühne <b>Expo Reception / Opening</b>			
13.00	Seitenbühne <b>Lunch</b>			
14.00	Seestudio <b>Overview of the Global LED Market and Key Technologies</b> <i>Emmanuel Dieppedalle Lumileds, USA</i>	Seefoyer <b>IoT Lighting Businesses and Technologies for Cloud Service Providers</b> <i>Niklaus Waser IBM, IoT Watson, Germany</i>	Propter Homines <b>High Quality Lighting Designs with SSL - Practical Examples and the New Role of Lighting Designers</b> <i>Ruari O'Brien, FILD, Germany</i>	Saal Bodensee <b>International Solid-State Lighting Alliance (ISA) Forum, China</b>
14.30	Seestudio <b>LED Lighting Modules - The Next Growth Opportunity in the Lighting Industry</b> <i>Pars Mukish Yole Développement, France</i>	Seefoyer <b>Scenarios and Use Cases for Smart Lighting Management Systems</b> <i>M.Eng. John Sayer Johnson Controls, UK</i>	Propter Homines <b>Light and Health - Newest Research Findings and Its Applications</b> <i>Mag. Wilfried Pohl Bartenbach, Austria</i>	Saal Panorama <b>Photonics Cluster Forum About Alternative Light Sources</b>
15.00	Seestudio <b>The LED-Disruption</b> <i>Dr. Stefan Kreidler onlog, Kreidler Mgt., Switzerland</i>	Seefoyer <b>Individual Resistance to the Adoption of Intelligent and Connected Lighting Products</b> <i>Prof. Jörg Lindenmeier University of Freiburg, Germany</i>	Propter Homines <b>Gender and Age Specific Preferences Regarding Lighting Conditions in Activity and Recovery</b> <i>Dr. Susanne Schweitzer Joanneum Research, Austria</i>	
15.30	Expo Area <b>Coffee</b>			
17.00	Seestudio <b>Zhaga: Addressing Smart Lighting and Standardized LED Components</b> <i>Dee Denteneer Zhaga Consortium, The Netherlands</i>	Seefoyer <b>IoT Architecture for Future Building Management Embedded Lighting Controls</b> <i>Dr. Walter Werner Werner Management Services, Austria</i>	Propter Homines <b>Cultural Aspects in Lighting Design with LEDs - Case Study Guzhen Town China</b> <i>Arch., Prof. Roberto Corradini, Marco Palandella, Roberto Corradini, Italy</i>	Saal Bodensee <b>International Solid-State Lighting Alliance (ISA) Forum, China</b>
17.30	Seestudio <b>Standards for Smart Outdoor Lighting will Futureproof Smart Cities</b> <i>MSc. Brian McGuigan TALQ Consortium, USA</i>	Seefoyer <b>Integrated Controls - Creating the Beach-head for the IoT Invasion</b> <i>MA Tom Griffiths ams AG, USA</i>	Propter Homines <b>Color Quality of LED Illumination: Metrics and Experimental Data</b> <i>Dr. Peter Bodrogi Technische Universität Darmstadt, Germany</i>	Saal Panorama <b>Photonics Cluster Forum About Alternative Light Sources</b>
18.00	Seestudio <b>LED Recycling for Circular Economy</b> <i>Dr. Jörg Zimmermann Fraunhofer, Germany</i>	Seefoyer <b>Enabling Smart Buildings Through the Internet of Light</b> <i>Dr. Christian Moormann Tridonic, Austria</i>	Propter Homines <b>Vertical and Horizontal Light Distribution Effects for Human Centric Lighting</b> <i>Volker Neu Vossloh-Schwabe, Germany</i>	
18.30	Parkstudio <b>Press Conference</b>			

# TECHNOLOGY & DESIGN DAY SEPT WED 21<sup>ST</sup>

Time	Light Sources	Smart Lighting Connectivity	Engineering	Forum Workshop
08.30	<b>Seestudio</b> <b>Latest Developments in LED Light Sources: Multi-functional Emitters Delivering Tunable White</b> <i>Wojtek Cieplik, LED Engin, USA</i>	<b>Seefoyer</b> <b>Lighting Fixtures as IoT Devices</b> <i>Justin Jiang UniBrite Technology, Taiwan</i>	<b>Propter Homines</b> <b>Beyond Distribution: Application Marketing, Engineering and Value-Added Services</b> <i>Sebastian Hülck, EBV Elektronik, Germany</i>	<b>Saal Bodensee</b> <b>Design Forum with the Leading Association of Italian Independent Lighting Designers, Italy</b> <small>APIL</small>
09.00	<b>Seestudio</b> <b>Monocrystalline Garnet Based Lumino-phores in High Power Light Sources</b> <i>Tomáš Fidler Crytur, Czech Republic</i>	<b>Seefoyer</b> <b>Intelligent Control System for Tuneable Light Spectra and Study of the Impact on Humans</b> <i>Prof. Blas Garrido, University of Barcelona, Spain</i>	<b>Propter Homines</b> <b>Maskless Laser Lithography Based Manufacturing and Replication of Freeform Micro-optical Elements</b> <i>Dr. Ladislav Kuna, Joanneum Research, Austria</i>	
09.30	<b>Seestudio</b> <b>New Glass-Based Phosphors for White LEDs</b> <i>Dr. Franziska Steudel, Fraunhofer, Germany</i>	<b>Seefoyer</b> <b>Overview and Trends in Wireless Communication Technologies for SSL</b> <i>Luco Lo Coco, NXP, Italy</i>	<b>Propter Homines</b> <b>Ultrathin Direct-lit LED Module with Beam Shaping Thin-film Optics</b> <i>Dr. Oscar Fernandez, CSEM, Switzerland</i>	
10.00	<b>Expo Area Coffee</b>			
11.30	<b>Seestudio</b> <b>Direct Mountable Chip, Chip-Scale-Packaging</b> <i>Daniel Doxsee, Nichia, Germany</i>	<b>Seefoyer</b> <b>DALI 2 - Smart Lighting and Color Control</b> <i>Dr. Scott Wade DALI, UK</i>	<b>Propter Homines</b> <b>Highly Reflective Diffuse and Specular Coatings for Lamps and Luminaires</b> <i>Dr. Francois de Buyt, Dow Corning, Belgium</i>	
12.00	<b>Seestudio</b> <b>Efficiencies and Color Quality of Latest LED Technologies</b> <i>M.Sc.Eng Mauro Ceresa Cree, Italy</i>	<b>Seefoyer</b> <b>Bluetooth Mesh and the Role of Standards in Widespread Adoption of Commercial Smart Lighting Systems</b> <i>MSc.Eng. Szymon Slupik, Silvair, Poland</i>	<b>Propter Homines</b> <b>Glass Optics with Micro Structures</b> <i>Dr. Ulf Geyer Auer Lighting, Germany</i>	
12.30	<b>Seestudio</b> <b>Lifetime and Reliability: Design Parameters of Mid-Power LEDs</b> <i>Dipl.-Ing. Ingolf Sischka, Lumileds, Germany</i>	<b>Seefoyer</b> <b>Security for Lighting in IoT - Group Communication</b> <i>Dr. Abhinav Somaraju, Tridonic, Austria</i>	<b>Propter Homines</b> <b>Enhancing Freeform Optics with Tailored Materials</b> <i>Dr. Angelika Hofmann, kdq Opticomp, Germany</i>	
13.00	<b>Seitenbühne Lunch</b>			
14.00	<b>Seestudio</b> <b>A New Binning Approach for White LEDs and Color Space Considerations</b> <i>Dipl.-Ing. (FH) Alexander Wilm Osram Opto Semiconductors, Germany</i>	<b>Seefoyer</b> <b>Enhanced Visible Light Communications</b> <i>Dr. Majid Safari University of Edinburgh, UK</i>	<b>Propter Homines</b> <b>Customized LED and Optical Device Packaging</b> <i>Dr.Ir. MBA Marco Koelink APC, The Netherlands</i>	<b>Saal Bodensee</b> <b>Spectrally and Tunable LED and OLED Lighting. EU FP7 Project Workshop</b> <small>Hi-LED</small>
14.30	<b>Seestudio</b> <b>Achieving Next Generation LED Lighting with Quantum Dots</b> <i>Steve Reinhard Nanoco Group, UK</i>	<b>Seefoyer</b> <b>Digital Power, a Shortcut to Intelligent &amp; Efficient Lighting</b> <i>Dipl.-Ing Kurt Marquardt Infineon Technologies, Germany</i>	<b>Propter Homines</b> <b>Thermal Challenges In SSL Automotive Lighting Applications</b> <i>Prof. Mehmet Arik Ozyegin University, Turkey</i>	
15.00	<b>Seestudio</b> <b>Bio-Inspired White Hybrid Light-Emitting Diodes</b> <i>Dr. Ruben D. Costa Friedrich-Alexander-Universität Erlangen, Germany</i>	<b>Seefoyer</b> <b>Near-zero Flicker, High Power Factor and Deep-Dimming - Eliminating the Supposed Conflict</b> <i>M.Sc. Dave Bannister, AccurlC, UK</i>	<b>Propter Homines</b> <b>Thermoelectrically Cooled High Power LEDs for Automotive Applications</b> <i>Dr. Roman Dekhtiaruk SmartThermoelectrics, Russia</i>	
15.30	<b>Expo Area Coffee</b>			
17.00	<b>Seestudio</b> <b>OLED Lighting: Technology Status and Manufacturing Capacity</b> <i>Dr. James Norman Bardsley Bardsley Consulting, USA</i>	<b>Seefoyer</b> <b>Advantages and Concepts of SSL Applications Utilizing Advanced Digital LED Drivers</b> <i>Mikael Pettersson SwitchTech AB, Sweden</i>	<b>Propter Homines</b> <b>State of the Art of Thermal Management</b> <i>Eduardo Benmayor Aismalbar, Spain</i>	
17.30	<b>Seestudio</b> <b>Latest Innovations and Breakthroughs in OLED Lighting</b> <i>Prof. W.A. Groen (Pim) Holst Centre, TNO, The Netherlands</i>	<b>Seefoyer</b> <b>LED-Retrofit based on AlGaIn/GaN-on-Si Field-Effect Transistor Drivers</b> <i>M.Sc. Andreas Zibold Fraunhofer, Germany</i>	<b>Propter Homines</b> <b>Al Oxide Technology for Device Cooling</b> <i>Dr. Michael Naish RUSALOX, Russia</i>	
18.00				
18.30	<b>Boat trip on Lake Constance</b>			
23.00	<b>Get Together Evening</b>			



# SOLUTION DAY SEPT THU 22<sup>ND</sup>

Time	System Quality	System Qualification	Applications	Workshops
08.30	<b>Seestudio</b> <b>Theory and Practical Measurement Results of Modulated Light</b> <i>Peter Erwin</i> <i>Lichtpeter, Germany</i>	<b>Seefoyer</b> <b>Photobiological Safety of SSL: Refining the New Approach</b> <i>Leslie Lyons</i> <i>Bentham Instruments, UK</i>	<b>Propter Homines</b> <b>The Light Pen - LED Direct Write Photolithography</b> <i>Dr. Nick Shepherd</i> <i>LEDesign, Austria</i>	<b>Saal Bodensee</b> <b>SSL Technologies for Horticultural Applications Workshop</b> <i>EPIC</i>
09.00	<b>Seestudio</b> <b>Flicker of LED Light Sources</b> <i>Dipl.-Ing. Margret Hedrich-Goeppert</i> <i>Neumüller Elektronik, Germany</i>	<b>Seefoyer</b> <b>Measurement of Spectral Rayfiles with Conventional Nearfield Goniophotometers</b> <i>M.Sc. Ingo Rotscholl</i> <i>Karlsruhe Institute of Technology, Germany</i>	<b>Propter Homines</b> <b>An Innovative Lighting Control System to Allow Parametric Relations with the Natural Environment</b> <i>Dr. Nicola Trivellin</i> <i>LightCube &amp; Artemide, Italy</i>	<b>Saal Panorama</b> <b>Internet of Things (IoT) &amp; Artificial Intelligence Workshop</b> <i>Jakajima</i>
09.30	<b>Seestudio</b> <b>Electrical Overstress Robustness of Latest Generation LEDs for General Lighting</b> <i>Dr. Matteo Buffolo, University of Padova, Italy</i>	<b>Seefoyer</b> <b>A Photometric Test System for LED Luminaires Based on Solar Panels</b> <i>Dr. Efi Rotem</i> <i>Ophir Photonics, Israel</i>	<b>Propter Homines</b> <b>Software Architecture Implementation for Street Lighting Management</b> <i>DI Juan José González Méndez</i> <i>ELT, Spain</i>	
10.00	<b>Seestudio</b> <b>Life-time Calculation of White HP-LEDs from 16,000 Hours Aging Data</b> <i>Dipl.-Phys. Max Wagner</i> <i>Technische Universität Darmstadt, Germany</i>	<b>Seefoyer</b> <b>Practical Guidelines for Sphere and Goniometer Measurements in View of CIE S 025/E:2015</b> <i>MA Mikolaj Przybyla</i> <i>GL Optic, Germany</i>	<b>Propter Homines</b> <b>Comparison of Reflective and Refractive Optics for LED Light Sources in Outdoor Lighting Applications</b> <i>Peter Almosdi, GE, Hungary</i>	
10.30	<b>Expo Area</b> <b>Coffee</b>			
11.30	<b>Seitenbühne</b> <b>Lunch</b>			
12.30	<b>Seestudio</b> <b>Exact Control of Spatial Light Distribution in High Power LED Applications by Silicone Lenses</b> <i>Dipl.-Ing. Christoph Baum</i> <i>Polyscale &amp; Fraunhofer, Germany</i>	<b>Seefoyer</b> <b>Solid-State Lighting Measurements - From Basics to Recent Developments Workshop</b> <i>Dr. Denan Konjhodzic</i> <i>Instrument Systems, TÜV, Germany</i>	<b>Propter Homines</b> <b>Optimization of Roadway Lighting Optics for Environment Adaptive Spatial Light Distribution with Two Channel Independent Dimming Control Capability</b> <i>Viktor Zsellér, Budapest University &amp; Arrow Electronics, Hungary</i>	
13.00	<b>Seestudio</b> <b>Material Selection for LED Modules in Harsh Environments, Outdoor and Industry</b> <i>Dr. Martin Pfeiler-Deutschmann</i> <i>Tridonic Jennersdorf, Austria</i>		<b>Propter Homines</b> <b>Beam Shaping System for Outdoor Applications</b> <i>Dr. Oon Chin Hin</i> <i>Temasek Polytechnic, Taiwan</i>	
13.30	<b>Seestudio</b> <b>Comparison of Luminaire Ageing with LED Lifetime Test Data</b> <i>Dr. Wolfgang Scheuerpflug</i> <i>Diehl Aerospace, Germany</i>		<b>Propter Homines</b> <b>Compact &amp; Cost Effective Luminaire Designs with On-Board Driver Modules</b> <i>Dave van Amelsfoort</i> <i>Viapaq Lighting, The Netherlands</i>	
14.00	<b>Closing</b>			

LpS 2016

LED  
professional

## GET SOCIAL!

Post your impressions or announcements on our  
**LpS 2016 & LED professional Social Media Wall.**



#LEDpro

# Tech-Talks BREGENZ - Francis Wong, AVP Lighting Business Unit, Lextar



## Francis Wong

Francis Wong is Associate Vice President of the Lighting Business Unit at Lextar Electronics. Mr. Wong received his Master's Degree in optics and photonics from the National Central University. He started working in the LED industry in 2002 and joined Lextar in 2013. Francis Wong is responsible for sales, marketing, product design, R&D and the supply chain of Lextar's LED lighting business. He has more than 14 years of experience in the LED domain, and is familiar with LED technologies, worldwide LED standards and regulations, and marketing.

Francis Wong, Associate Vice President Lighting Business Unit at Lextar, visited the LED professional team for a Tech Talk in Bregenz after Light & Building 2016. Siegfried Luger, Arno Grabher-Meyer and Dr. Guenther Sejkora could discuss Lextar's history, current position, future orientation and strategies. Further exciting topics were the ongoing technology developments, the requirements on modern lighting systems, the latest lighting trends from Light & Building and the relevance of OLED and IoT technology for the company.

**LED professional:** Thank you very much, Mr. Wong, to you and your team for coming to the Festspielhaus for this TechTalk Bregenz. We really appreciate the effort you made to come here. This is a great opportunity to sum up your impressions of the Light + Building and also to answer some questions about Lextar, the LED business and lighting. Could you please give as a short company description for a start?

**Mr. Wong:** Actually, Lextar was founded in 2008 and the headquarters is in Taiwan. Our mother company is AUO - one of the largest TFT-LCD suppliers in the world - and the largest in Taiwan. We have a chip foundry in Taiwan and a packaging house in Taiwan and in China. We also have a lighting assembly line in Suzhou, which is near Shanghai.

In 2007 Apple launched a new notebook, the MacBook Air, where LED was used for backlighting instead of CCFL. This was the moment when AUO decided that LED would be a good strategy for the LCD industry. So they started up Lextar in 2008.

**LED professional:** So Lextar is 100% a daughter of AUO?

**Mr. Wong:** At the very beginning Lextar was set up as an epitaxial and chip factory. Soon AUO started to consolidate all the related subsidiaries, so Lextar became an LED chipmaker, a package house and also a lighting and luminaire maker. In 2014 Lextar's revenue was about \$500 million (US), and kept flat in 2015 because the LED prices have gone down and the shipping costs have increased by 20%-25%.

**LED professional:** And there was a shift from backlighting to lighting as well, wasn't there?

**Mr. Wong:** Yes, you're right. By 2015 about 40% of our revenue came from lighting. So there was a big application shift from backlighting to lighting. If you look at the

end application for something like a mobile phone or a notebook or TV - actually the notebook has increased very quickly from 100 million to 170 million devices a year. And also LCD TVs ramped up very fast during the last three to four years. Right now it is very rare to see CRT based TV - maybe in a very old hotel. But what I want to say is that the percentage of LCD is very high - maybe 95% or even more. Adoption rates for Notebooks are already 100% and for TVs are at least 80%. So I would say that there aren't much more LEDs to be sold for the backlight industry. That's why we moved our focus from backlighting to lighting.

**LED professional:** If you look forward to the year 2020, what do you think the ratio would be for backlighting and lighting for Lextar?

**Mr. Wong:** We still have a very big customer base for backlighting through AUO. So we will be able to maintain the portion. If you check the prices for backlighting, you will see that it isn't dropping as fast as it is for lighting.

**LED professional:** So it will still be a 40/60 ratio?

**Mr. Wong:** No - lighting will grow. We will keep the volume of backlighting but lighting will grow. We also have a new business unit, which is related to automotive LED. We believe the LED market in automotive applications will also grow very quickly within the next three to four years. The new business unit also includes UV and IR solutions.

**LED professional:** Can you please explain your strategy for vertical integration?

**Mr. Wong:** It is quite unique and we are the only company in Taiwan that does vertical integration for lighting. This means we produce the chip, we do the packaging for LED, we also make the module or replacement lamp and we produce lighting fixtures. And now we are also

doing connected lighting, which means, in fact, software for lighting.

The major backlighting business provides LEDs for small portable devices. For mid-size LCD for TVs we provide a module because in this way we can still maintain very good profits in backlighting.

In lighting it's a similar situation. Of course, we are still selling the LED to the customer. But we have more value added products like LED modules. We try to enhance our value added service to the customer by providing fittings, which, in turn, improves the margin.

Our new business is automotive and UV applications. This is a very special application. In automotive, our product already qualifies for the certification AEC-Q101 which is a certification for car components. The 101 means that we can supply a single replacement device for the next 10 years. This is a requirement from the automotive industry and it's very difficult for the LED industry to maintain the performance of an LED for 10 years!

**LED professional:** So you are present in all stages of the value chain - how big is your turnover with components compared to higher integrated products?

**Mr. Wong:** Like I mentioned for the backlight, 80% should be module based and for lighting there are about 50% module or luminaire based. So Lextar sells about 70% module based or luminaire based and 30% is component business. We are a company that is very rare - selling more modules than LEDs.

Other companies are profit centre oriented. One profit centre is running chips, the other does packaging and the third does luminaires - and each is accountable for his profits and losses. So the chip maker doesn't target the luminaire maker, but rather, other big companies. He does a lot of things

Lextar is set up as an innovation focused company with fast-growing patent numbers

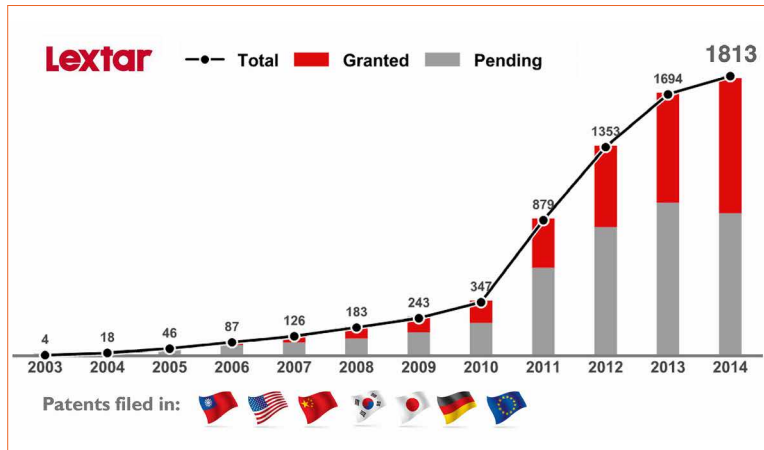

for them but the lighting team probably has a better idea of what he could provide in terms of profit for the corporation.

At Lextar it is totally different. We handle everything from the chip to the luminaire. We can have our own strategy. For example, if we think there is a very good "LED idea" for the luminaire we will implement it into our lighting luminaire first.

**LED professional:** That sounds very logical. You can drive innovations in all areas. But what about the market itself? What about your clients? On a higher level, you are competing with your clients on the component level - so how do you deal with that on the market?

**Mr. Wong:** That's a very good question. In the supply chain for the module and luminaire business, we only do ODM. Our core business is still LED chip and LED packaging. Our company sells LEDs but we never sell luminaires under our own brand. We bring the idea to a luminaire company and we produce our products for them under their brand. So this is how we make a differentiation and different strategy in different sections. Therefore we are not competing with the module or luminaire manufacturers.

**LED professional:** In that case, you sell your customer components and if they want, you will also sell them the module or even the complete luminaire?

**Mr. Wong:** That's correct.

**LED professional:** Some companies try to become technology leaders or cost or price leaders. Where do you want to be the leader?

**Mr. Wong:** Although Lextar is not small we are not a manufacturing or capacity oriented company. We like to do new technology, innovations.

**LED professional:** What does this mean in terms of intellectual property and patents?

**Mr. Wong:** If you follow the Lextar IP portfolio we are probably the biggest one in Taiwan. In 2015 we were have approx. 2,000 IPs filed and granted. This is the highest number in Taiwan's LED industry. This is covering chip technology and package technology and also applications.

**LED professional:** Are your patents equally spread over the value chain or are they more in the chip and component sectors?

**Mr. Wong:** It's probably about 60% to 70% in chip and components. But we work in the entire field and do research in the whole value chain.

Driver for innovation is a combination of different things. As a technology driven company, I think the first driver is technology and of course the next thing would be quality. We are trying to make a quality product, not a low cost product. But the most important driver, I would say, is technology.

**LED professional:** To generate these technology driven innovations and IP - what percentage of your revenue goes into research?

**Mr. Wong:** Around 15%. I will explain how we see the contribution of new technologies to the evolution of light: Around 50 to 80 years after Edison created the light bulb, people started thinking about saving costs. This led to the invention of the halogen lamp. After the annual saving was fulfilled, people were thinking what else light could be. As a consequence, ambient lighting technologies were invented. Not only in places like the opera or restaurants, but also in residential lighting. They wanted to create mood lights for people.

And now we are moving to the next stage - IoT, the internet of things. Saving energy can be done because of better efficiency of the light source or the control gear. But IoT offers a better way - lighting can't only be controlled by humans, it can also be controlled by AI - artificial intelligence. So this will be a revolution for the lighting industry. Just controlling a lighting device is ok, but it's not smart. We will bring smart ideas to the control system.

To make it smart we need sensors, just like robots have sensors. A robot has to hear the voice, see the people. It is the same with lighting devices. So we have a new business unit that is working on a new opto sensor. We just buy it and embed it into the luminaire. For street lighting or public lighting you can embed a surveillance camera and monitor for safety reasons. Or we can embed an infrared sensor to sense occupation. Finally we also create the system or software platform that is behind the lighting device.

**LED professional:** Another topic seen as a driver for innovation is human centric lighting. Do you also do research in this direction?

**Mr. Wong:** We have to ask the simple question: why do people

### Colour temperature changes sequentially for improved circadia

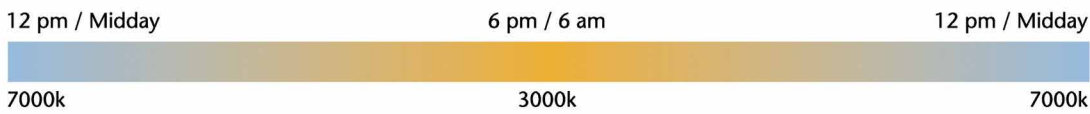

Lextar's goal, when it comes to human centric lighting, is to match the light quality of the sun as closely as possible - no easy task

#### Fit-in BBL

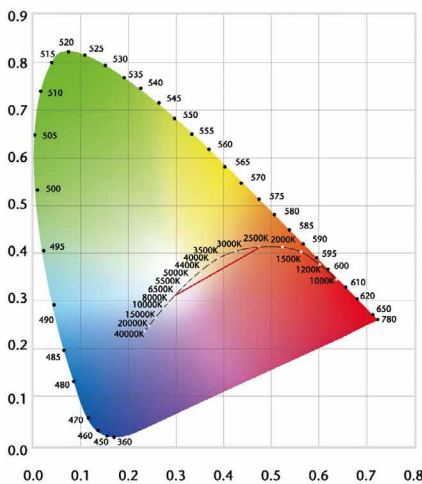

#### Simulate Sun Light

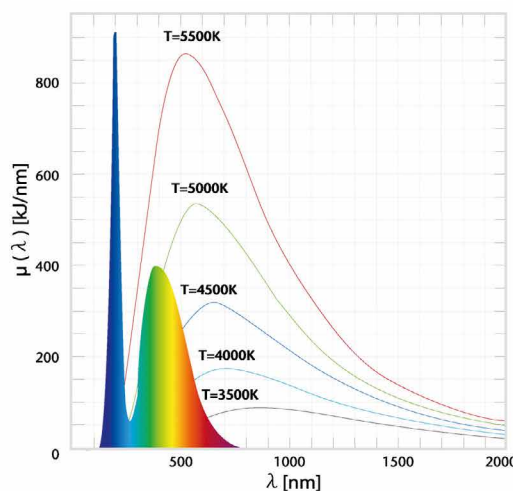

Francis Wong sees two big challenges for human centric lighting. One is fitting the black body line properly when tuning CCT and an exact reproduction of the spectral distribution of sunlight with LEDs

need light. Most of the time we have the sun for about 12 hours a day and you can see everything, you can work, you can walk. You feel safe under the sun. So actually lighting should simply recreate the sunlight and not just light up people. We shouldn't use only LEDs. LEDs are cheating people. I say cheating because there isn't white. There is only blue and yellow, green and red that makes you feel like there is white. But actually it's not white at all. So we are thinking about how to recreate a sunlight spectrum.

When we talk about human centric lighting we are talking about how light can affect people biologically. For example, if you see sunlight in a

cold color temperature you will feel energized and may go for a walk. But if the color temperature is that of a sunset, you would feel that it's time to go home. So there are two challenges in human centric lighting.

The first is how to create light close to the BBL - the black body line. The BBL represents the colors that you receive from the sun. In artificial lighting people often just take one 2700 K LED and one 6000 K LED and change the ratio between these two. Actually, there will be a color shift between the sunlight color and the artificial light color. You can feel this color difference, so it's still not human centric lighting.

Another challenge is how to create a continuous spectrum close to the sun light spectrum. Right now LED spectra have a very high peak in blue a little bit of intensity in the green and yellow and nothing else. Probably you are saying - oh we do the CRI 95. Yes, a little more in red but still not enough. So it's different to sunlight. This is another thing we need to develop, that's why technology is so important.

We use many kinds of technologies trying to do this - we have three R&D teams working on the different technologies to generate a continuous spectrum, similar to sunlight. We don't know what will be the best solution at this moment.

Lextar sees IoT as one of the major future topics and is well prepared with their connected lighting concept that provides a location based service

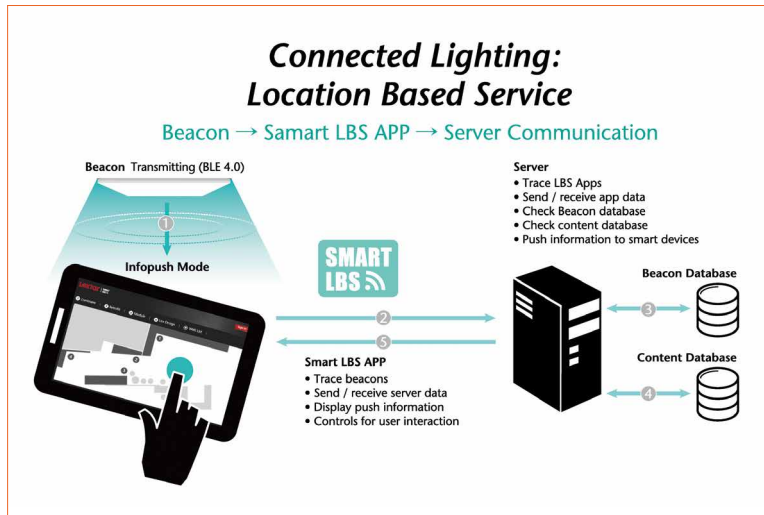

**LED professional:** So maybe we should now come to the Light & Building. I think it was a very interesting show last week, and I wanted to ask you - what was new from Lextar?

**Mr. Wong:** Actually at the Light & Building we demonstrated a lot of small, connected lighting devices. Most of our customers received a pad when they entered our booth so that they could use the pad when they walked around the booth to see what they were looking at. So if the customer saw something interesting they could click it on the pad and then they got a quote or specifications.

So that was one thing we were showing but we also showed a lot of connected lighting devices. But I think the most interesting product that we showed was the lighting fitting with the automatic ambient light sensor. Another interesting product is a consumer lighting product that can create ambient light in your room. We tried to make it very simple - for example we take a photo - and upload it to the device and the device will read the color tone from the picture and the ambient light will create a color tone similar to it.

**LED professional:** So in theory you could take a photo from your last holidays and get back into your holiday mood! And if you look at

the Light + Building in general, what were the most important trends you could identify?

**Mr. Wong:** I think IoT based controlling. That's the thing that everybody is talking about and also Human Centric Lighting.

**LED professional:** Were people only talking about it or did they already show products that can really be used for the market?

**Mr. Wong:** I think everybody showed products that could be used on the market. Most of the products are for home applications, a lot of them controls lighting by the smart phone. It's probably ok for the home applications but if you look at the history for adopting LED lighting, you can see the first implementation will always be commercial. The second implementation will be for consumer application. We believe this is same for the IoT. You have to create something for commercial applications first because they have money.

So at Lextar we spend more resources in commercial applications IoT. We believe IoT will be used in commercial lighting before customer lighting.

**LED professional:** At the Light + Building in 2014 almost every second booth showed applications

with OLED and everybody said that OLED was the lighting of the future. But in 2016 there was much less attention paid to it. How do you see the future development of the OLED?

**Mr. Wong:** I'm not a fortune-teller but in my point of view there is still a gap between OLED and LED in terms of cost and in terms of efficiency. I think that OLED efficiency is certainly at a level that people can accept. But LED also improved a lot. Three years ago if I told you that I could make a luminaire at 100 lumens per watt you would have said that it's good enough. Today people are talking about 120 to 150 lumens per watt at system level. OLED right now is just about 100. So there is still a gap between them. But the OLED is a flexible light source. So for decorative lighting they are quite unique.

**LED professional:** Does Lextar drive its own OLED research?

**Mr. Wong:** AUO has its own because AUO manufactures them for small devices. But it's not for lighting or backlighting, it's display technology.

**LED professional:** If you look ahead and think about Light & Building 2018 - what do you think your position will be? What products will you be showing?

**Mr. Wong:** This year we just demonstrated a few IoT based controls for LED lighting devices. I think in 2018 this will be Lextar's main product line. But not just Lextar. I believe it will be the main product for everybody. I also believe that by 2018 human centric lighting will make a breakthrough.

**LED professional:** Thank you very much for the interview and for being so open with us.

**Mr. Wong:** You're very welcome. ■



## Explore the full spectrum!

### High-precision LED/SSL measurement solutions from Instrument Systems

- ▲ Leading test equipment for standard & high-power LEDs & OLEDs
- ▲ Proven solutions for production, R&D and quality control applications
- ▲ Complies with all International and European standards like CIE S025 or EN 13032-4
- ▲ Engineered and made in Germany

**Opt for our expertise!**

LGS 1000  
Goniophotometer  
with new features



**We bring quality to light.**

# Quality and Health Aspects of LED Lamps for the European Residential Lighting Market

Because of shortfalls in regards to consumer information about high quality, energy efficient, substitute products for incandescent lamps, there has been a significant amount of irritation on the side of the consumer. As part of the Intelligent Energy Europe Program of the European Union, Prof. Dr. Georges Zissis from the Paul Sabatier - University Toulouse and his team investigated 370 LED lamps. All relevant parameters of 95 different lamp types from store shelves in 12 European countries were measured and evaluated regarding quality and health issues.

Solid State Lighting (SSL) is currently revolutionizing the field of lighting and its practices. In the long term, inorganic and organic light emitting diodes (LEDs), will become the most widely used light sources. White LEDs have shown a steady growth of their luminous efficacy for more than fifteen years; promising to make significant energy savings as they replace older lighting technologies. The EU-regulations on Eco-design and Labeling for lighting provide an essential framework for supporting energy efficient lighting solutions in the domestic sector. The Eco-design regulation defines the phase-out of inefficient incandescent lamp technology while the Labeling regulation supports the demand for highly efficient light sources. However, due to shortfalls regarding guidance of consumers to high quality energy efficient substitute products for incandescent lamps significant irritation has occurred among buyers and a negative attitude against substitution technologies, namely CFLs and LEDs, has been enforced. This negative perception of the energy efficient technologies has been further

amplified by the fact that for both CFL and LED lamps many low quality products are still flooding the market, and by some announcements concerning health issues for such products. A smooth transition from old inefficient lighting technology to highly efficient lighting requires further supportive measures and information services for the consumer. Making good energy efficient products for residential lighting visible for the consumer by product testing can prevent this. To this end, comprehensive testing of LED high efficiency products has been done and will be presented in the first part of this paper. The second part of the paper will deal with some health issues related to LED lighting, namely blue light hazard and light flickering.

## LED Lamp Quality Evaluation Campaigns

To support the promotion of high quality LED lamps for residential lighting the IEE-project PremiumLight implemented a broad market-oriented action in twelve EU countries which was focused, among other things, on selecting high quality LED lamps from each participating country market and systematically testing them in a laboratory. The geographic region of the action covered 12 countries represented by the Austrian Energy Agency (Austria), Berlin Energy Agency (Germany), SEVEN (Czech Republic), Politecnico Milano (Italy), Energy Saving Trust (UK), Energy Plano (Denmark), Motiva (Finland), University Toulouse 3 (France), EKODOMA (Latvia), ISR-University Coimbra (Portugal), Ecoserveis (Spain), TEM (Sweden) [i].

PremiumLight, however, focused on the lamp performance of two product classes; namely LED omnidirectional lamps and LED spots. Testing results provide concrete essential consumer information on good products comprehensively fulfilling consumer needs in terms of quality, energy efficiency, environmental aspects



etc. Testing results were included in all dissemination activities in the consortium and via key actors.

The PremiumLight project focused on high quality lighting products that were commonly available in the EU markets where they were purchased. For this purpose, the project developed criteria to define an efficient, high-quality lamp. The criteria were designed to cover the main product characteristics that are relevant and observable by the consumer. Several of these criteria were defined earlier as, for example, by the Quality Charter for Solid-State Lighting [1] or the tier scheme proposed by the International Energy Agency 4E-SSL Annex [2]. Additionally, the eco-design regulations 244/2009 and 1194/2012 [3] [4] also recently established minimum standards. These minimum standards define the minimum requirements that must be met by any lamp that is sold on the EU-market today.

The following aspects were considered for establishing PremiumLight criteria.

#### Lamp efficacy:

The lamp efficacy describes how much light the lamp produces per watt of electric power. It is expressed in lumen per watt (lm/W). In the early days of LED technology efficacy was often measured for cold lamps under laboratory conditions. However, the efficacy of a lamp at 25°C is much higher than for lamps at typical operating temperatures. The PremiumLight criteria established for LEDs for the purpose of the project were efficiency class A+ following EU Directive 92/75/EC calculation method based on the value of Energy Efficiency Index (EEI). If today, the most efficient LED lamps can reach more than 100 lm/W under real-life use conditions, it is not possible to give a single value in terms of associated luminous efficacy in lumens per watt because the EEI value differs for the various product classes.

#### Average lifetime and lumen maintenance:

For LEDs intended for domestic lighting purposes, manufacturer declared lifespan ranges between 10,000 and 50,000 hours. It would take one or more years to test lamps to determine whether such declared lifespans are accurate. Therefore, this kind of testing is not helpful for the consumer, since lamp models are typically replaced every few years. However, the useful lifetime of LEDs is not only defined by the total time until lamp failure but by the decrease of lumen output over time as well. When lamp lumen output has declined to 70% of the declared value the effectively useful lamp lifetime has been reached. Thus the lamp lifetime of LEDs is often declared by "L70B50" values, respectively the number of hours that it takes for at least 50% of the lamps to experience an at least 70% decline from the initial lumen output. Testing shall follow IEC/PAS 62612 Ed.1 [5] including a temperature cycling shock test and a supply voltage switching test with a number of cycles equal to half or all of the rated lamp life hours. The PremiumLight quality suggests a lifetime of least 20,000 h for premium-quality LEDs. A shorter lifetime of e.g. 15,000 hours might therefore be acceptable for LEDs in case they are sold at comparably low prices. The drawback of this is the fact that a low (15,000 h) lifespan determined by L70B50 may include a sample where 25% of the sample fails at 5,000 h and this of course is not acceptable for high quality products.

#### Color rendering:

The Color Rendering Index (CRI) indicates how well the human eye can identify specific colors when illuminated by a specific lamp. A CRI value of 100 is achieved by standardized daylight or by a standard lamps (incandescent lamps are used as standards). Other light sources typically have lower CRI values. The eco-design regulation requires a minimum CRI of 80. The UK EST LED program required CRI

> 85 in 2011 and CRI > 90 in 2012. Today there are already LED lamps available with a CRI between 90 and 95. PremiumLight set a minimum CRI selection criterion at 80.

#### Correlated color temperature:

The color temperature of a lamp indicates the appearance of white light that may range from yellowish warm white to bluish cold white. With reference to IEC/PAS 62612 Ed.1 [5], the Quality Charter [1] for Solid-State Lighting requires CCT (Correlated Color Temperature) ratings for lamps for domestic use should be between F2700 (CCT=2,720 K, x=0,463 and y=0,420), F3000 (CCT=2,940 K, x=0.440 and y=0.403) or F3500 (CCT=3,450 K, x=0.409 and y=0.394). However, color temperature is not a quality criterion properly speaking, it is linked to the ambiance that the lamp will create and it directly influences the consumer's satisfaction. The selection of a specific color temperature depends primarily on consumer preference. For household lighting in northern European countries warm white light with CCTs ranging from 2,700 K to 3,000 K is preferred. However, it has been reported that in southern European countries, in particular, more neutral to cool white lamps with CCTs of 5,000 K and above are requested. A quality criterion, however, is the uniformity of the color temperature for a specific lamp model, thus the deviation of the color temperature from the declared values should be small. This is important to avoid visible color variation in a multi-LED spots, lamps, or even luminaires.

#### Other issues:

Another criterion that has been addressed by PremiumLight is the dimmability of LEDs. Dimmability is not a quality criterion and there are dimmable and non-dimmable lamp models on the market. Dimmability is also dependent on the type of dimmer used. Additional criteria that have partly been tested in the

**Table 1:**  
“PremiumLight Quality  
Criteria”

Parameter	LED bulb	LED spot	Comments
Min. luminous efficacy [lm/W]	60	50	These values have been selected following previous market survey studies in Europe and USA (2011-12) and correspond to 10% best products
Min. wattage [W]	8	4	When looking for LED-bulbs replacing GLS and halogens the lumen output value should be privileged (minimum 470 lm). For LED spots the luminous flux is not a discriminant criterion and beam aperture has to be taken into account. Beam angle is given by manufacturer and not tested in our laboratories
Min. luminous flux [lm]	470	-	
Min. beam angle (°)	-	20	
Min. Energy Class	A+	A+	Calculation based on EEL value by using experimental luminous flux et input power values
Min. Color Rendering Index	80	80	The actual definition of CRI is not fully applicable to LEDs
Color temperature range [K]	2,500 - 4,000	2,500 - 4,000	For domestic GLS replacement (warm white) a color temperature of CCT<3000 K is appropriate, however, for southern countries also CCT<4000 K is acceptable
Min. Life span L70B50 [h]	20,000	20,000	As given by manufacturer and not tested in our laboratories at this stage of the project. Ageing measurements are underway
Min. number of switching cycles	50,000	50,000	

PremiumLight project are flicker and power factor. These aspects are less easily checked by consumers since the relevant information is normally not provided on lamp packaging. LEDs may differ considerably regarding these two criteria. Thus some lamp models show strong flicker and low power factor whereas other lamps perform quite well.

Table 1 shows all criteria used for the anonymous selection of PremiumLight quality lamps for testing.

The PremiumLight project measured the following properties / quantities and compared them to manufacturers' declarations.

- RMS Voltage (V) and Current (A)
- Electrical input power (W)
- Power factor - PF and  $\cos\phi$
- Total luminous flux (lm)
- Luminous efficacy (lm/W)
- Correlated Color Temperature - CCT (K)
- Color Rendering Index - CRI
- Chromaticity difference -  $\Delta u'v'$
- Light Flicker percentage (%)

Power factor, chromaticity difference and Light Flicker Percentage were included as an option for all products as they were defined to be important for Europe. Manufacturers do not usually declare these values.

All laboratories involved in the project used the IEA 4E SSL Annex Test Method version 1.0 [6]. This Test Method includes the strictest requirements of many SSL test methods imposed by various national and regional metrology standards. The Annex Test Method encompasses all the requirements contained in the SSL test methods already available in the USA, Japan, China, and also including the draft of the SSL test method being developed jointly by International Commission on Illumination (CIE) and Comité Européen de Normalisation (CEN). The terms used in this section follow definitions in CIE S017 [7], IEC 62504 [8], IEC 60050 [9] and LM-79:08 [10]. Product conformity was tested in the three laboratories that have all the necessary, certified equipment for these types of measurements: Toulouse University - LAPLACE laboratory (France), Swedish Technical Research Institute (Sweden) and the Laboratory of City of Vienna (Austria). The three laboratories compared their performance in a round-robin campaign on three test-lamps previously defined according to the project needs: Each laboratory measured the luminous flux, Correlated Color Temperature and Color Rendering Index for all three test-lamps. The results from 3 laboratories were collected and

analysed. These results showed that (1) values for Luminous flux in lumens deviated at maximum of  $\pm 6,0\%$ ; (2) values for Correlated Color Temperature in kelvin deviated at maximum of  $\pm 4,0\%$ ; (3) values for Color Rendering Index deviated at maximum of  $\pm 1,5\%$ .

The following paragraphs summarize the most important features of the testing protocol and the key definitions.

#### Ambient Conditions:

The ambient temperature during the measurement of the product shall be maintained at  $(25\pm 1)^\circ\text{C}$ . The temperature sensor shall be placed at the same height and within 1 m of the LED lamp under test. Airflow around the tested lamp shall be maintained at less than 0,2 m/s such that normal convective airflow induced by device under test is not affected.

#### Position & Stabilization:

The operating position of lamps shall be specified according to the normal use conditions of the product. Prior to taking measurements, the product under test shall be operated at the rated condition and allowed to stabilize so that the changes in electrical power and total luminous flux are less than

0,5% over a 30-minute window, based on one-minute monitoring. If necessary, longer stabilization time can be considered and in the case that the lamp is not stabilized the measures are taken 2 h after the switch-on time.

#### Electrical measurement conditions:

The lamps under test have been operated at the rated voltage (230 V AC) and frequency (50 Hz). The tolerance of the test voltage for AC-input is  $\pm 0,2\%$  of the rated value and the tolerance of frequency is  $\pm 0,2\%$ . AC power supplies used for this testing shall have a sinusoidal voltage wave shape at the prescribed frequency with the total harmonic distortion not exceeding 3% under a resistive load. If the product has dimming capability, measurements shall be performed at the maximum input power condition. The RMS voltage (V), current (A), power (W), and power factor, shall be measured at the time photometric measurements are taken. The AC power meters used for this testing shall have a sampling rate that is capable of resolving the current wave for the tested product: 61000-3-2 [11] states that the electrical characteristics of lighting products should be analyzed in a frequency range covering the fundamental (50 Hz) and up the 40<sup>th</sup> order (2 kHz). EN/IEC 61000-4-7 [12] indicates that power measurement equipment should be able to analyze components up to 9 kHz.

#### Photo-colorimetric measurement conditions:

For the measurement of total luminous flux, CCT, chromaticity tolerance ( $\Delta u'v'$ ) and CRI a sphere-spectroradiometer shall be used at each testing laboratory. These devices shall be calibrated with a total spectral radiant flux standard traceable to a National Metrology Institute (NMI). The spectroradiometer used shall cover the wavelength range of at least 380 nm to 780 nm, and the bandwidth (full width half maximum) and scanning interval no greater than 5 nm. Wavelength scale uncertainty shall be within 0.3 nm. Color quantities measured for tested products include correlated color temperature (CCT), and general Color Rendering Index (CRI).

#### Useful luminous flux definition:

This quantity is used only for directional lamps, other than filament lamps, and it is defined by EU regulation No 1194/2012 [13] as follows: directional lamps with a beam angle  $\geq 90^\circ$  and carrying a warning on their packaging in accordance with point 3.1.2(j) of the above cited EU regulation Annex: rated luminous flux in a  $120^\circ$  cone, other directional lamps: rated luminous flux in a  $90^\circ$  cone.

#### Luminous efficacy definition:

The luminous efficacy,  $\eta$ , is expressed in lumens per watt (lm/W) of the product under test.

Luminous efficacy is determined by the following relation:

$$\eta = \frac{\Phi}{P}$$

where  $P$  and  $\Phi$  are respectively the electrical input power and the total luminous flux, measured following the above described methodology.

#### Power Factor definition:

The power factor ( $PF$ ) and  $\cos \phi$  are defined as follows:

$$PF = \frac{P}{VI} \quad \text{and} \quad \cos \phi = \frac{P}{V_0 I_0}$$

where  $P$ ,  $I$  and  $V$  are respectively the RMS electrical input power, current and voltage;  $I_0$  and  $V_0$  are the voltage and current sinusoidal terms at 50 Hz.

### Results from Testing Campaigns

Comprehensive testing of the high efficiency lamp products is now complete. More than 330 lamps of 85 different types were tested during the project. For each model a sample of three to five lamps were tested. For each brand the sample size can be considered as relatively small but for products like lamps manufactured at large batches by industrial machines it can be considered as representative. Increasing the sample size implies larger testing times and higher

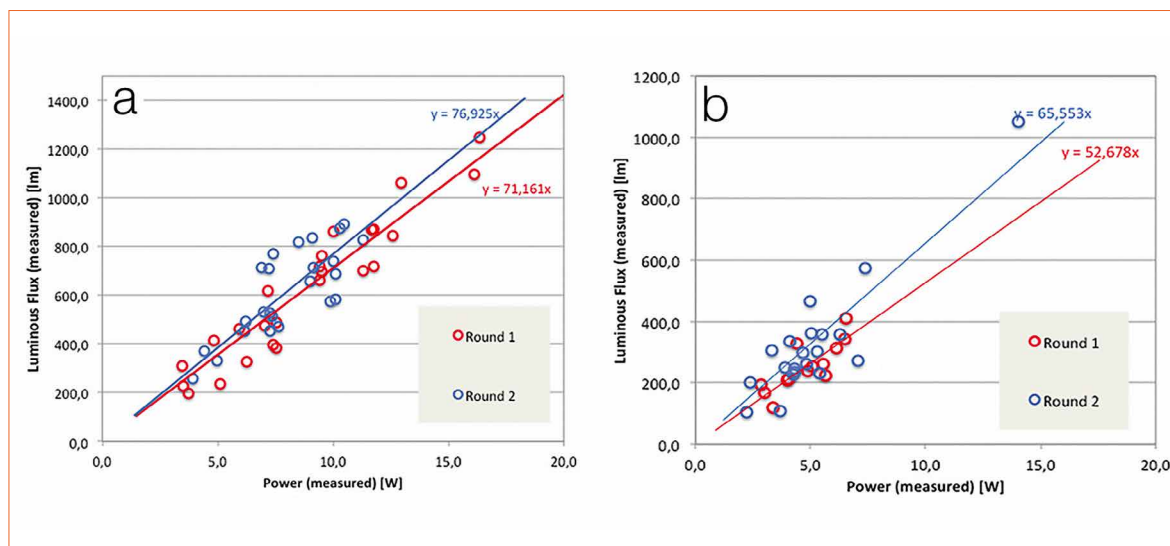

**Figure 1a&b:**  
(a) Measured luminous flux (lm) vs measured electrical power (W) for LED omnidirectional lamps (each point is the average of 3 to 5 measured lamps)  
(b) Measured luminous flux (lm) vs measured electrical power (W) for LED spots (each point is the average of 3 to 5 measured lamps)

testing cost. Our results shown that for all lamps of the same brand the standard deviation for each studied quantity stayed at acceptable low level (<5%).

**Lamp types included:**

- 49 types of LED omnidirectional and candle-type lamps (sockets E27, E14, B22d and B15d)
- 35 types of LED spots (sockets: E27, E14, GU10, GU5.3, GU5 and GU4) and 1 model of AR111 downlight

the measured input power for omnidirectional LED lamps and LED spots. For spots the maximum luminous efficacy was found to be 94 lm/W and the minimum value was 30 lm/W. In the case of omnidirectional lamps these values were 104 lm/W and 47 lm/W respectively. We also saw that some omnidirectional LED lamps offered a luminous flux equivalent to a 75 W GLS lamp (1,000 lm). Furthermore, the AR111 downlight produce a flux of more than 1,000 lumens.

observed luminous efficacy for LED bulbs passed from 71 lm/W to 77 lm/W and thus increased by 8% within the year lapse between the 2 testing rounds. For LED directional lights this passed from 53 lm/W to 66 lm/W corresponding to improvement of more that 30% in a year.

Figures 1a and 1b show the measured total luminous flux versus

Based on the above measurements, we found that globally, the average

**Figure 2:** Distribution of measured luminous efficacies (lm/W) for LED bulbs (blue bars) and LED spots (red bars)

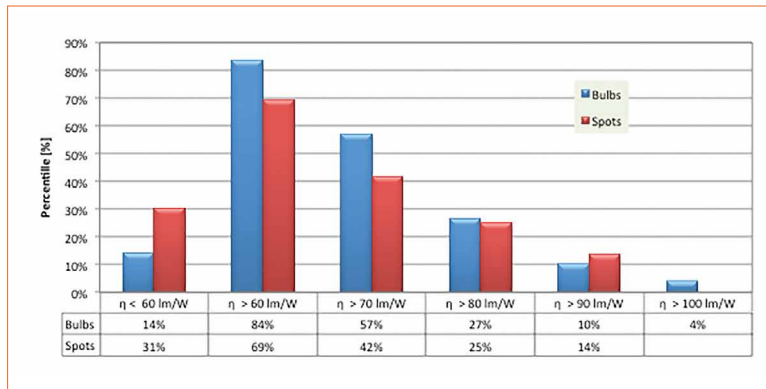

Figure 2 shows that for LED omnidirectional lamps 15% of the batch had an efficacy lower 60 lm/W and for LED spots 31% of the batch had efficacy lower than 50 lm/W.

As shown in Figure 3a and 3b, input power declarations by manufacturers were found to conform generally to measurements within a  $\pm 10\%$  commonly accepted confidence interval. For instance, we found one model of LED omnidirectional lamp that showed a 21% deviation for input power. However, almost 33% of the LED spots were outside of this interval.

The situation is different for total luminous flux values: 63% of the

**Figures 3a&b:** (a) Observed deviations between declared and measured for input power, luminous flux and luminous efficacy values for LED bulbs (b) Observed deviations between declared and measured for input power, luminous flux and luminous efficacy values for LED spots



omnidirectional LED lamps and only 39% of LED spots were within a  $\pm 10\%$  interval of manufacturer declared values as imposed by EU directive 2009/125/EC [14]. For one LED spot model this deviation goes up to 109% (that leads to 123% deviation on luminous efficacy).

Figure 4 compares the EU Directive 92/75/EC [15] EEI values declared for omnidirectional LED lamps to our measurements. Significant deviations are detected but only 6 models are labeled incorrectly (four models are declared to be A class, but we found them to be A+ class, and two models were declared to be A+ and we found them to be A). The majority of studied lamps are A+ products (70,8% of the batch) and no B energy classes were found in the full batch. However 29,2% of the models are class A and don't fulfill PremiumLight quality requirements.

Concerning light color characteristics, all tested lamp types, but one, were warm white

(CCT < 3,100 K). Only minor deviations between declared and measured values were observed. Color temperature only varied within  $\pm 5\%$  confidence interval.

Figures 5a and 5b show the results concerning correlated color temperature for LED bulbs and LED spots. It can be seen that if for LED

bulbs the declarations are rather conform, the situation is worse for LED spots.

Finally, figure 6 shows the declaration errors for the colorimetric characteristics (CCT and CRI) for LED spots. Deviations higher than  $\pm 5\%$  are not acceptable. It is evident that compliance CRI

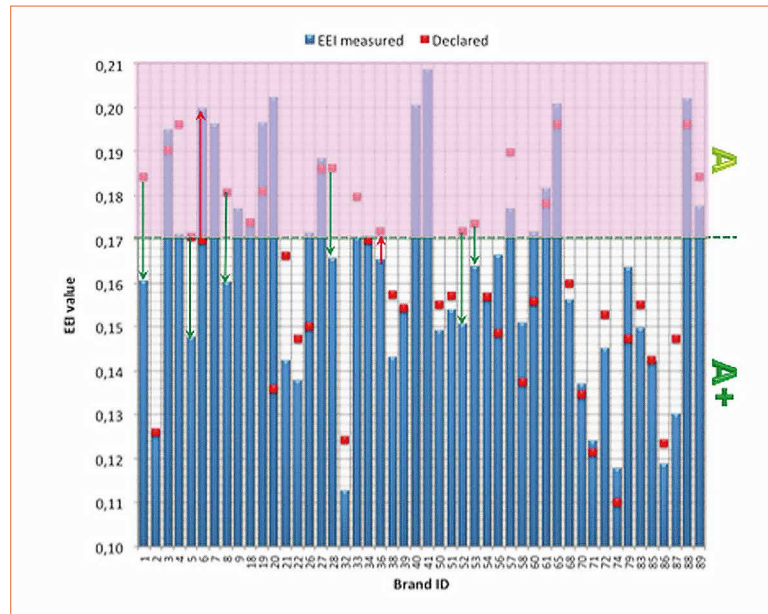
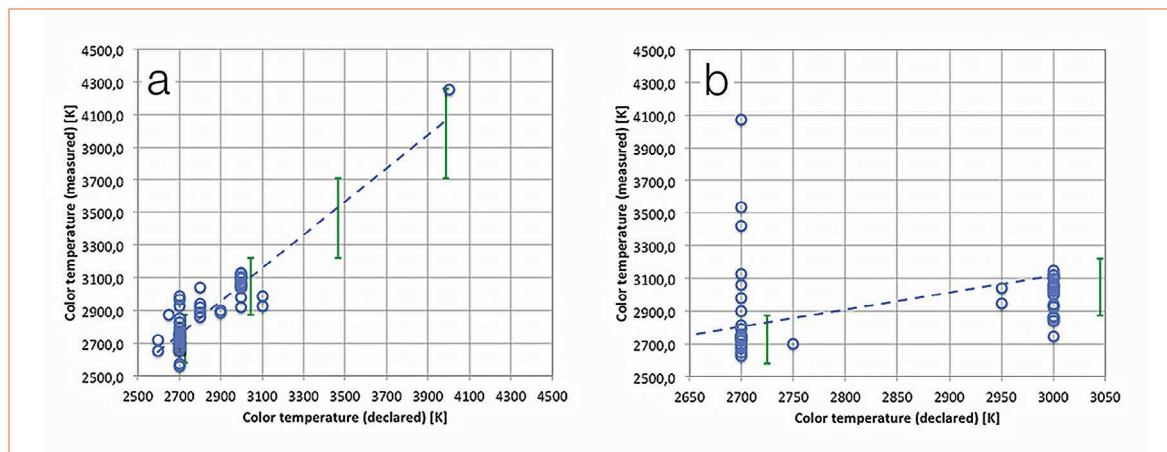

Figure 4: EEI value and energy class measured (blue bars) and declared (red dots)



Figures 5a&b: (a) Declared and measured correlated color temperatures for LED bulbs. The green error bars represent the ANSI acceptable deviation (b) Declared and measured correlated color temperatures for LED spots. The green error bars represent the ANSI acceptable deviation

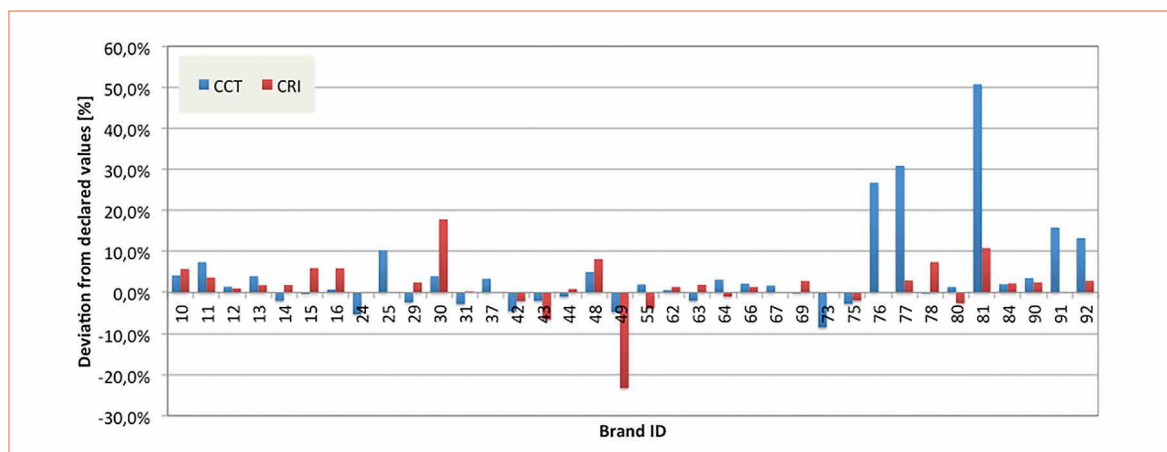

Figure 6: Observed deviations between declared and measured for correlated color temperature (CCT) and color rendering index (CRI) for LED spots

requirements, with a maximum observed deviation 25,4%, is much more difficult for manufacturers than consistency with CCT declarations (maximum observed deviation 10,5%).

Concerning Color Rendering Index, most tested lamps showed a measured CRI of around 80, therefore above the minimum level currently required by the eco-design regulation. Thus the CRI of most of the LEDs tested is at a standard level and not particularly high. However, in the studied batch lamp models available with a CRI around or above 90, we found were significantly better.

### Health Issues for LED Lighting Systems

As any new or emerging technologies, LED lighting products should be proven to be at least as safe as the products they intend to replace. In new lighting applications where older technologies could not be employed, the safety of LED products should be assessed considering new or unusual conditions of usage.

The potential risks posed by LEDs to human health can be classified in the following categories:

- Electrical safety
- Potential risks due to exposure to electromagnetic fields
- Potential risks due to the emitted optical radiations: interactions of the optical radiations with the skin and the eye (photobiological safety), undesired effects of optical radiations on vision (glare and flickering effects in particular), effects of optical radiations on circadian rhythms

The first two points are due to the specific spectral characteristics of white LEDs as compared to other artificial light sources. This section of the paper focuses on the last point of the above stated list, and more especially on the blue light hazard and flickering.

### Blue light hazard

Photobiological hazards are related to the effects of optical radiation on the eye. LEDs currently used have the advantage of emitting a negligible amount of ultraviolet and infrared radiations. Therefore, only the effects of the visible light have to be considered. Blue light is recognized as being harmful to the retina, as a result of cellular oxidative stress. Due to the high brightness of LEDs, the retinal illuminance levels are potentially high and must be carefully considered. Blue light is also suspected to be a risk factor in age-related macular degeneration. For all LEDs and products using LEDs, a photobiological blue light risk assessment must be carried out to determine whether or not the MPEs can be exceeded in the conditions of usage. The IEC 62471 standard [16] defines two different criteria to determine the viewing distance. Light sources used in general lighting should be assessed at the distance corresponding to an illuminance of 500 lx. Other types of light sources should be assessed at a fixed distance of 200 mm. The choice of the viewing distance in IEC 62471 is discussed in this paper, as it is sometimes ambiguous and not always realistic in the context of the real usage conditions.

Based on IEC 62471, lamps and lamp systems are classified into risk groups for various photobiological hazards. The risk group depends on the maximum permissible exposure time (MPE time) assessed at a given viewing distance.

### IEC 62471 risk groups:

- Exempt Group (RG0: no risk): MPE not exceeded within 104 s
- Risk Group 1 (RG1: low risk): MPE not exceeded within 102 s
- Risk Group 2 (RG2: moderate risk): MPE not exceeded within  $2,5 \times 10^{-1}$  s (eye blink time)
- Risk Group 3 (RG3: high risk): MPE exceeded even for momentary or brief exposure (less than  $2,5 \times 10^{-1}$  s)

For the past few years, blue light exposure data have been provided by LED manufacturers, professional lighting associations, independent laboratories, and governmental agencies. It was found that the retinal blue light exposure levels produced at a distance of 200 mm from the user by blue and cold-white LEDs (bare LEDs and LEDs equipped with a focusing lens) exceed the MPEs limits set by ICNIRP after an exposure time comprised between a few seconds for high power blue LEDs to a few tens of seconds for high power cold-white LEDs.

Figure 7 shows blue-light weighted radiance LB as defined by ICNIRP [17] or the six blue LEDs chosen by the ANSES working group [18] and published in [19]. In this example, the LEDs were operated such that they emitted a radiant flux of 0.5 W, which is about half the rated maximum value.

For this study, we used various single LEDs under conditions of constant luminous flux. When

**Figure 7:** Variation of blue-light weighted radiance LB with the exposure time determined for six types of blue LEDs (as function of the position of blue peak wavelength). The red curve is the exposure limit value. The intersect point corresponds to the maximum permissible exposure time. It can be used to determine the risk group

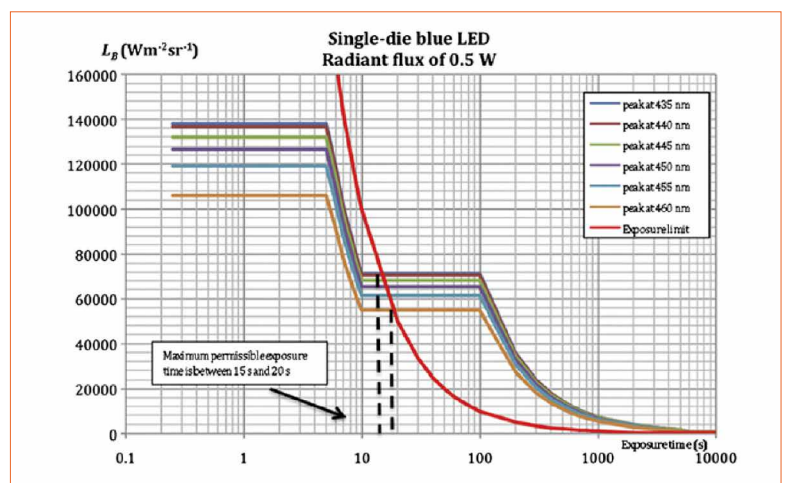

cold-white LEDs were operated such as to provide a luminous flux of 100 lm, the exposure limit value was never reached and the risk group was always 0 (no risk). By increasing the luminous flux to 200 lm, all the cold-white LEDs fell into risk group 2 (moderate risk) with maximum permissible exposure times comprised between 40s and 100s. Similarly, neutral-white LEDs operated at a luminous flux of 100 lm all fell in risk group 2 (moderate risk) with maximum permissible exposure times comprised between 40s and 100s. Similarly, neutral-white LEDs operated at a luminous flux of 100 lm all fell in risk group 0. When operated at 200 lm, the exposure limit value was reached at an exposure time of about 100 s, thus the studied products fell into the risk group 1 (low risk). Warm-white LEDs never exceeded the exposure limit value and were always in risk group 0 (no risk), even when they were operated at a flux of 200 lm. In fact these warm-white LEDs should reach a luminous flux of at least 500 lm to belong to risk group 1 (low risk). Table 2 recapitulates these results.

None of the studied single-die LEDs presented a high risk (risk group 3). Blue LEDs and cold-white LEDs may belong to risk group 2, according to their color temperature and their operating point. Likewise, neutral-white LEDs may belong to risk group 1. On the contrary, all warm-white LEDs belonged to risk group 0.

**Light Flicker**

Flicker is the modulation of the light output that can be induced by fluctuations of the mains voltage supply, residual ripples in the DC current powering, or deliberate modulations of the LED input current such as the pulse-width modulation (PWM) used for dimming applications.

It is known that exposure to light flicker (in particular at frequencies between 3 Hz and 55 Hz) can cause photosensitive epileptic seizures in various forms, depending on the individual and his visual pathology, the contrast, the wavelength and the viewing angle or distance [20].

LED type	Luminous flux (lm)	Risk Group	No Risk	Max exposure time (s)
Cold White	100	RG0	No Risk	-
	200	RG2	Moderate Risk	40-100
Neutral White	100	RG0	No Risk	-
	200	RG1	Low risk	100
Warm White	100	RG0	No Risk	-
	200	RG0	No Risk	-
	500	RG1	Low risk	100

**Table 2:** Risk groups and maximum exposure times for various LED lamps as measured by CSTB in the frame of ANSES working group



**Figure 8:** Some experimental percentage flicker values of various lamp technologies as obtained in LAPLACE laboratory and EU-PremiumLight project

According to literature, light flicker is not usually perceptible at frequencies higher than 70 Hz, but it can still affect people. For example, people suffering from migraines are more likely to be sensitive to flicker at high frequencies [21]. Also, for people suffering from specific medical conditions, flicker may have some serious consequences.

Light flicker combined to rotating motion or spatial patterns may be responsible for stroboscopic effects. Stroboscopic effects might induce hazards to workers in proximity to rotating machines and tools.

Commercially available LED lamps may have serious light flickering behavior at twice the mains frequency (in Europe mains frequency is 50 Hz thus the observed residual flicker frequency is equal to 100 Hz). This light flicker is mainly due to the residual voltage fluctuation after the AC/DC rectifier in the lamp power supply. The measurements presented in this work show that there are a few commercial LED lamps without any flicker. However, a significant number of products demonstrated abnormally high flicker. Some products have fluctuations of about

100% of the luminous flux, corresponding to a light output varying from zero to the maximum value.

Our set of test lamps included LEDs as well as CFLs and incandescent lamps used as references. Figure 8 shows the experimental percentage flicker values for some tested lamps. It should be noted that a 100 W incandescent lamp has a flicker percentage of 10% due to the filament temperature variation that follows the power waveform. Good quality CFLs may reach a percentage flicker of 20%. The highest Flicker Index value for tested CFL lamps was found to be 0.14, a value rather compatible with US recommendations. The situation is completely different for LEDs. As can be seen in Figure 8, LEDs had completely arbitrary behaviors. Some of them feature high quality power supplies that include reliable AC/DC rectifiers and filters. They

displayed very low flicker, close to zero (not measurable). Other devices had percentage flicker values up to 100%. In this case, the light output goes off every 10ms. Eight LED lamps were found to fully respect the conditions imposed by the Energy Star requirements (Flickering Index < 0,1), whereas all examined CFLs fulfilled that condition.

### Conclusions

Overall, PremiumLight's extensive lamp testing showed that very efficient, high-quality, LED lamps are available today with efficacy levels up to 104 lm/W (for an omnidirectional LED bulb), CRI up to 95 and up to 1040 lm output for an AR111. Many LED bulbs were confirmed to be A+ class and to have Power Factors higher than 0,5. Our measurements showed that many tested products had a Color Rendering Index of 90 and even higher. Thus the light quality offered

by the lamps tested, at least in terms of color rendering, is already approaching levels close to halogen lamps and the standard incandescent lamp. The performance of the LED products tested conform, in large part to the manufacturers' declarations, but some singular cases of significant deviations from declared performance were found. Although the majority of the tested lamps showed high quality and efficacy, our results also indicated that some brands do not provide the quality and efficacy claimed by manufacturers. Such products showed problems regarding efficacy, luminous flux, color rendering and other quality aspects.

Concerning the blue-light hazard, and more particularly, in consumer applications (retrofit LED lamps for instance), we strongly support the adoption of a regulation to limit the risk group to RG1 at the minimum

- LED Lighting
- LED Display

- LED Illuminant
- LED Packaging

- LED Chips
- LED Equipment .....



# LED CHINA 2016



The World's Preeminent LED Trade Platform  
**19 - 22 September 2016**  
Shanghai New International Expo Centre (SNIEC)



Organizer  
UBM Trust Co Ltd  
Tel: 86 20 3810 6261, 3810 6263  
Email: led-trust@ubm.com  
Website: www.LEDChina-sh.com

Shanghai Office  
Tel: 86 21 6157 3921  
Email: info-trust@ubm.com

Our Network  
Japan  
Tel: 81 3 5296 1034  
Email: ubmcanonjapan@ubm.com

Taiwan  
Tel: 886 2 2738 3898  
Email: info-tw@ubm.com

Korea  
Tel: 82 2 6715 5406  
Email: jamesh.lee@ubm.com

USA  
Tel: 1 516 562 7855  
Email: cecilia.wun@ubm.com



viewing distance encountered at home, which is 200 mm. The measurement campaigns carried out by the authors, as well as by several other independent laboratories, showed that most indoor LED lamps and luminaires already comply with this requirement. It is not a critical issue for the LED industry. However, the notion of a safety distance would actually be more appropriate to communicate to the installers and to the users, especially to the general public. The safety distance of an LED based product would be the minimum distance for which the

blue light hazard risk group does not exceed RG1 and this value must be indicated on the package. For LED products handled exclusively by professionals, all necessary measures to limit the final risk group to RG1 have to be taken and guaranteed by the installers.

Concerning light flicker, we tested more than fifty different lamps for flickering. Our samples included LED lamps as well as some CFLs and incandescent lamps as benchmarks. The highest Flicker Index value for tested CFL lamps was found to be of 0.14. LED lamps

had completely arbitrary behaviors. Some of them, built with high quality power supply, displayed zero flicker (not measurable) while some other devices reached per cent flicker values of up to 100%. In fact, only eight LED lamps have been found to fully respect the US recommendations (Flicker Index < 0.1), while all the tested CFLs fulfilled that condition. Consumers should be vigilant about that fact. In this paper, we described a rapid method to detect flicker using a smart phone camera. ■

#### Acknowledgements:

The project PremiumLight is co-funded by the Intelligent Energy Europe Program of the European Union (Grant n° IEE/11/941/SI2.615944). The authors wish to express their gratitude for this financial support.

#### Notes:

For more information on the IEE-project PremiumLight project see: [www.premiumlight.eu](http://www.premiumlight.eu)

#### References:

- [1] [http://iet.jrc.ec.europa.eu/energyefficiency/sites/energyefficiency/files/files/documents/eu\\_led\\_qc\\_background\\_report\\_10\\_feb\\_2011\\_final.pdf](http://iet.jrc.ec.europa.eu/energyefficiency/sites/energyefficiency/files/files/documents/eu_led_qc_background_report_10_feb_2011_final.pdf)
- [2] International Energy Agency Annex 4E-Solid State Lighting, <http://ssl.iea-4e.org/>
- [3] <http://eur-lex.europa.eu/LexUriServ/LexUriServ.do?uri=OJ:L:2009:076:0003:0016:en:PDF>
- [4] <http://eur-lex.europa.eu/LexUriServ/LexUriServ.do?uri=OJ:L:2012:342:0001:0022:EN:PDF>
- [5] IEC/PAS 62612 Ed.1 "Self-ballasted LED lamps for general lighting services with supply voltages > 50 V - Performance requirements", IEC, 2013
- [6] IEA 4E SSL Annex: Interlaboratory Comparison Test Method 1.0, 2013, [http://ssl.iea-4e.org/files/otherfiles/0000/0059/SSL\\_Annex\\_2013\\_IC\\_Test\\_Method\\_v.1.0.pdf](http://ssl.iea-4e.org/files/otherfiles/0000/0059/SSL_Annex_2013_IC_Test_Method_v.1.0.pdf)
- [7] International Lighting Vocabulary, Standard CIE S 017/E, 2011
- [8] IEC 62504 "General lighting - Light emitting diode (LED) products and related equipment - Terms and definitions", 2014
- [9] Electropedia: The World's Online Electrotechnical Vocabulary, <http://www.electropedia.org/>
- [10] LM-79 Approved Method: Electrical and Photometric Measurements of Solid-State Lighting Products, IES, 2008
- [11] IEC 61000-3-2 ed4.0 "Electromagnetic compatibility (EMC) - Part 3-2: Limits - Limits for harmonic current emissions (equipment input current ≤ 16 A per phase)" is an international standard concerning the harmonics emitted by electric equipment, 2014
- [12] EN/IEC 61000-4-7 "Electromagnetic compatibility (EMC) -Part 4-7: Testing an measurement techniques - General guide on harmonics and interharmonics measurements and instrumentation, for power supply systems and equipment connected thereto", IEC, 2002
- [13] <http://eur-lex.europa.eu/LexUriServ/LexUriServ.do?uri=OJ:L:2012:342:0001:0022:en:PDF>
- [14] <http://eur-lex.europa.eu/legal-content/EN/TXT/PDF/?uri=CELEX:32009L0125>
- [15] <http://eur-lex.europa.eu/legal-content/EN/TXT/PDF/?uri=CELEX:31992L0075>
- [16] CIE/IEC 62471, "Photobiological safety of lamps and lamp systems", First Edition 2006-07
- [17] Guidelines on Limiting Exposures to Non-ionizing Radiation, ICNIRP 7/99 (2006).
- [18] Effets sanitaires des systèmes d'éclairage utilisant des diodes électroluminescentes (LED), Saisine n°2008-SA-0408, Rapport d'expertise collective de l'Agence Nationale de Sécurité Sanitaire de l'Alimentation, de l'Environnement et du Travail (ANSES), 2010
- [19] Behar-Cohen F., Martinsons C., Viénot F., Zissis G., Barlier-Salsi A., Cesarini J.P., Enouf O., Garcia M., Picaud S., Attia D., Progress in Retinal and Eye Research 30(4): 239-257 (2011)
- [20] [http://en.wikipedia.org/wiki/Photosensitive\\_epilepsy](http://en.wikipedia.org/wiki/Photosensitive_epilepsy)

# Flicker Beyond Perception Limits - A Summary of Lesser Known Research Results

Since the introduction of fluorescent lamps, the lighting industry knows about flicker issues. However, many aspects are still unclear. Especially effects beyond the flicker fusion threshold are mostly ignored, and sometimes even denied. Dr. Walter Werner, CEO of Werner Consulting, gives a summary of research results indicating that further research is needed and that for high quality lighting very likely a much higher PWM modulation frequency is required.

For the most part, light flicker has not been a topic of conversation when talking about lighting except, perhaps, during the 1980's when research was being done on fluorescent and discharge lamps. Simple solutions and electronic ballasts seemed to solve the issues then and the subject was forgotten again. However, LED lighting has

changed the situation once more and light flicker is a very popular topic of conversation now, raising the questions of: Why should we care about flicker at all? What does flicker fusion really mean? Is there a safe threshold for flicker? Should we care about flicker beyond the visible experience? Do we understand flicker and do we know enough about its effects?

## A Short History of Flicker

Flicker in lighting is a relatively young phenomenon. Our biology has adapted to changes in the light provided by the sun, the moon, fire and candles. But all these changes are "slow" and "irregular" compared to the flicker created by technical effects. The same applies to the old thermal artificial light sources like gas light or incandescent electric lighting:

Figure 1:

Human vision has evolved and adapted to irregular and slow fluctuations in light intensity like what we get from sunlight filtering through the leaves of a tree or a campfire at night



The thermal inertia of the hot filament makes the changes in light output slow and with the mains frequency high enough, small and invisible. Only incandescent lamps on the 16.67 Hz circuits the railway system used in the early days of electrification in some areas had some visible flicker.

The first time flicker was an issue was with movies. The main question was how continuous movement could be created by a series of still frames shown rapidly one after the other. There are two aspects to this: How many frames per second are needed for a smooth impression, and how is it possible to avoid the flicker impression created by the short dark interval needed for the transport of the celluloid between the frames. Experiments showed that smooth movement impressions can be achieved with 15-18 frames per second, and a professional smooth impression at 24 frames per second (the number of frames needed directly affects the cost of a movie, therefore low frame rates are favored). But when those movies were shown to a wider community, some of the audience experienced severe health issues. When investigated further it was clear that the health issues were not connected to the content of the movies but rather the 18-24 Hz flicker was identified as the source of the problem. Today this is known as photosensitive epilepsy, a severe condition caused by flicker mainly in the range between 8 and 30 Hz, and decreasing above. To avoid the 8-30 Hz frequency range without tripling the cost of the films the movie industry tripled the shutter frequency and showed the same frame three times before moving to the next. Now they operate with flicker in the 60-80 Hz range which has been proved to circumvent photosensitive epilepsy. It also made the overall flicker impression that was experienced when not directly staring at the screen much better. Experiments showed that the flicker impression for most of the audience went away completely above approx. 120 Hz.

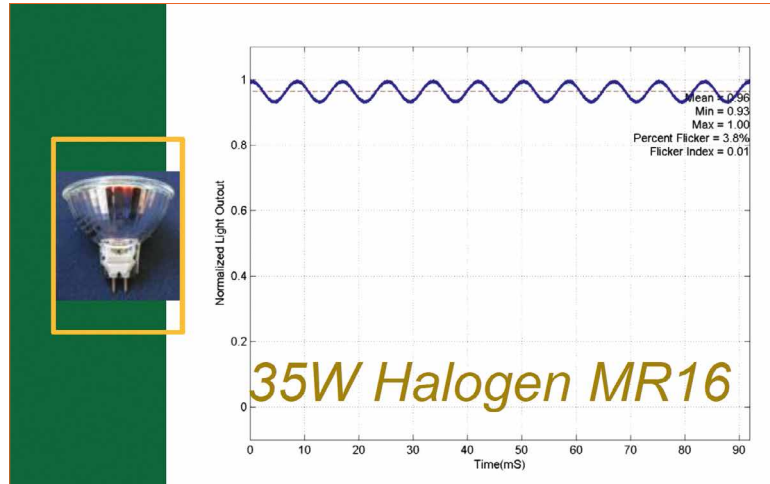

**Figure 2:** Even incandescent and halogen lamps flicker but virtually no flicker is visible due to them being an artificial light source at a grid frequency of 50-60 Hz (Credit: Naomi J. Miller, Brad Lehman; DoE & Pacific Northwest National Laboratory)



**Figure 3:** Photos from CRT TV monitors show the 25/50 Hz flicker as banding. An effect that appears very similar when taking pictures or videos using flickering LED lamps

### Flicker and Television

The development of the TV screen and the fluorescent lamp right after World-War-Two brought flicker back into focus and new attempts to understand flicker better were made.

To keep transmission bandwidth in a reasonable range, the TV screens could handle just 25 (Europe) or 30 (US) frames per second at a reasonable number of lines. To stay out of the flicker frequency range and get into a 50/60 Hz frame rate on the screen, broadcasting was organized in half-frames with interlacing lines: A really tricky way to get out of the flicker frequencies that caused photosensitive epilepsy. But in any case TV sets were known for the visual flicker impression they caused and in some areas they were called a "flicker box" (german: "Flimmerkiste").

The TV exploited the fusion issue to its maximum: It was actually a single spot that rapidly moved line by line over the screen, relying on the eyes to fuse it into a full image.

The flicker integration by the eye was believed to be caused by the bio-chemical process of the detection that has a substantial relaxation, the experience of a full screen view written by a fast moving single spot, supported this believe.

For photographers, the TV added a challenge that had not been known up until then: Making a "screenshot" with a reasonably short exposure delivered a single bright dot with a short tail and with longer exposures, a section of the screen stayed grey (there were no black screens in those days) instead of a nice picture. Also, TV or movie cam shots from TV screens ended up with vertical moving bars caused by interference if no special precautions were made.

### Flicker and Lighting

Like the TV exposed us to flicker in our living rooms, the fluorescent lamp took it to the work place. The flicker issues caused by the early fluorescent lamp were not experienced as an issue as in most

Figure 4:

With the introduction of FL lamps and the use of magnetic ballasts, flicker issues became apparent and critical in lighting. The issues were solved by using multiple lamps operated on differently shifted phases (Credit: Naomi J. Miller, Brad Lehman; DoE & Pacific Northwest National Laboratory)

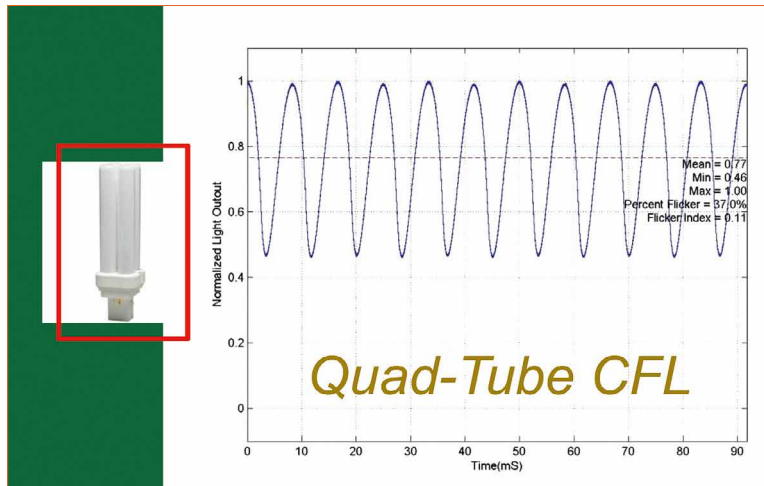
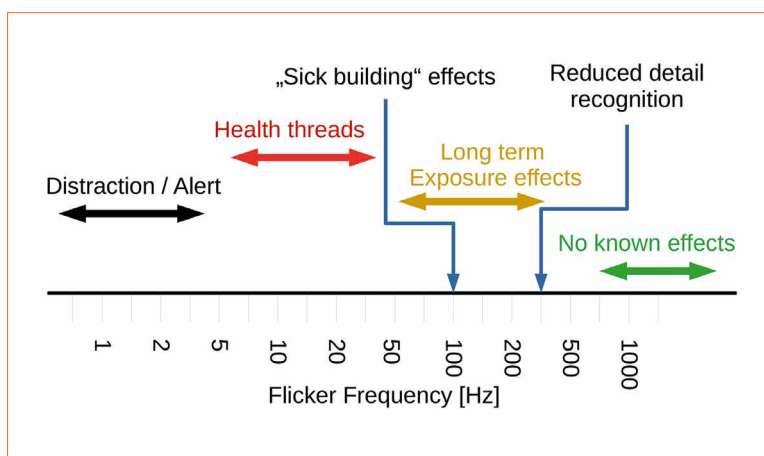

Figure 5:

Various flicker frequencies have different effects on health or visual and cognitive performance



applications it was substantially reduced by having multiple lamps per luminaire on differently shifted phases, substantially reducing the depth of the dark phase and adding to the flicker frequency which stayed well above 100 Hz.

Finally, in 3-phase connected environments with multiple lamps per luminaire and each lamp on either an inductive or capacitive ballast with the corresponding phase-shift, opaque white covered luminaires and little to no direction, the residual flicker in larger rooms (like production sports spaces) ended up above 600 Hz with a flicker depth of << 25% of the intensity! This was creating a practical kind of "no flicker" experience. The setting also allowed for TV shots without disturbing stroboscopic effects.

With the upcoming higher efficiency of the now thinner fluorescent lamps, the use of phosphors with lower relaxation time, and the highly

directional anodized louvers where each lamp illuminated a specific area, the lighting industry started creating noticeable flicker without noticing it. Technically, a single fluorescent lamp creates flicker of 100 /120 Hz, and a full dark phase that covers some 25% of the time (the dark time depends very much on the line voltage applied).

With the flicker of discharge lamps in traffic lighting a new aspect of flicker was on the edge of being noticed: the stroboscopic effects of lights that pass by at higher angular speed.

In the mid 1980's modern offices were found to make people sick in the long run (sick days rose, the number of respiratory infections increased, and there were a higher number of eye strain issues), and all kinds of root causes were thoroughly researched. Besides air flow issues, including wrong humidity management and exposure to germs by those early ventilation

and heating systems, the "sick building syndrome" identified eye strain as being caused by long (multiple months/working hours) exposure to flicker at 100 Hz as being part of the issue [1].

This result was not smiled upon. In fact, many believed that the cause was poor lighting design, improper computer screens and the like. It was difficult to believe that there could be biological health effects when no flicker features were visible at all, especially with literature expounding the fact that the retinal cell was not able to follow that flicker frequency.

All the experience with older installations were in contradiction to that research, and in addition the lighting industry was accused of using influential arguments to push sales of the new "electronic ballast" technology that was able to dramatically reduce flicker. It is the destiny of most long-term-exposition-effects that they will be ignored for the long-term.

## Bio-Medical Issues of Flicker

In the meantime, bio-medical research revealed additional features of the eye: besides the well visible movement that is caused by scanning the environment (looking around), a continuous and rapid but small movement was detected: The position of the eye jitters minimally around the actual focus of sight in all directions at an astonishing speed: It jitters at a rate of 80-100 position changes per second. (Individually different, and somehow rising with age).

This led to wide speculation and hefty discussions, especially as the movement was so fast that it outdid the fusion frequency, creating a contradiction: Why should the eye move faster than the receptors are able to create signals? At this time it was believed that the fusion frequency is caused by the limited response time of the retina cell. The full evolutionary reason for this



kdg  
**OPTICOMP**  
High End Optical Moulding



## optics are king

That's why we are in service  
of High End Optical Development  
and Production. kdg OPTICOMP

Meet us at **LpS 2016, Booth A5**  
September 20 - 22, 2016, Bregenz



# kdg

kdg OPTICOMP, c/o kdg mediatech GmbH  
A-6652 Elbigenalp 91, Tel. +43 5634 500 700  
opticom@kdg.at, www.kdg-opticomp.com

[www.kdg-opticomp.com](http://www.kdg-opticomp.com)

**Figure 6:**

With LEDs inertia in the light emission, poorly designed drivers (left) and PWM dimming (right: e.g. on approx. 80% level) brought flicker back to lighting (Credit: Naomi J. Miller, Brad Lehman; DoE & Pacific Northwest National Laboratory)

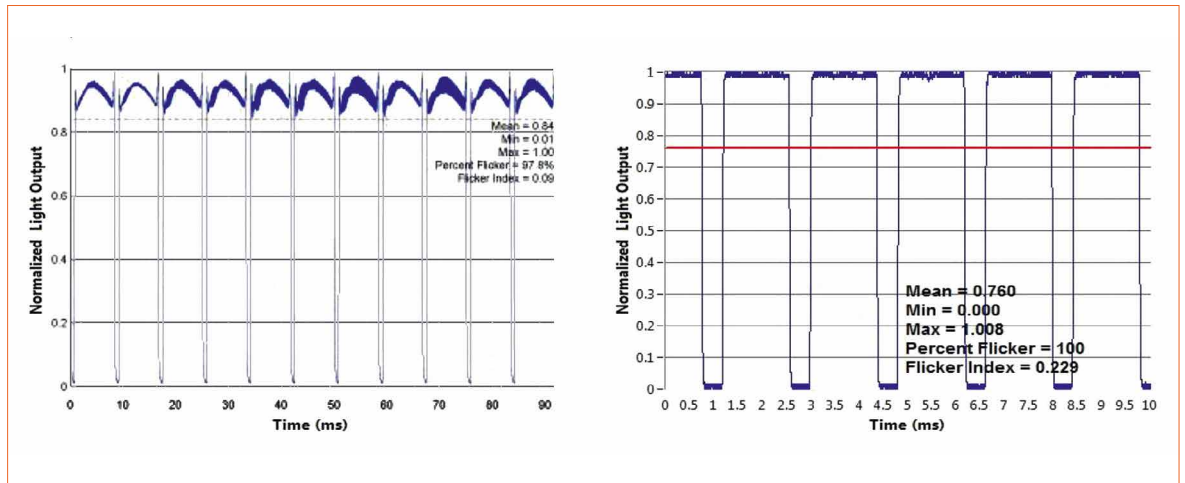

effect, now called "ocular micro tremor (OMT)", and the full bundle of purposes this bio-medical flicker generator possibly serves is still an object of research today.

In the meantime it became clear that the fusion frequency is caused by the brain handling the data stream, the eye apparatus has been shown to be able follow optical signals up to at least 200 Hz.

The linear fluorescent lamp moved away from flicker with the T5 lamp that was used on electronic circuits only. Quality vendors showed "residual ripple" figures in the single digit or below percentage range as a quality feature of their product. Contrary to that, the compact fluorescent lamps brought flicker back to lighting, especially to the home environment, with the deployment (and finally legal push) of the "energy saver" replacement lamps that were also for private use, where designers cared more about the cost and less about the light quality achieved. Most of them feature substantial flicker at double the mains frequency.

With the high-pressure discharge lamps used in street lighting, flicker was reduced as the lamp also emits a substantial portion of light during the change of polarity.

The flicker of TV sets and computer screens was attacked by the quality industry when it was understood that it is connected to eye strain related health issues. TFT screen

technology, fast micro- and display controllers together with cheap RAM technology allowed for low flicker at higher frequencies with the screens (e.g. "100 Hz TV" was a quality sales argument for a while).

### The Return of the Flicker

When LED's first came into TV sets they were usually driven by some internal circuitry with no need for dimming, and therefore no flicker was applied. But when the LED's came into lighting, dimming and color change (by dimming the color components relatively) became easily accessible, and the PWM technology mainly used to dim brought flicker back into the main area of lighting. The LED follows the electric current applied without any inertia in the light emission. As higher PWM frequencies cause higher cost and losses, flicker at comparatively low frequencies was back, the "flicker knowledge" of the early 1990's and the drive to avoid flicker above the photopic epilepsy range in the lighting environment was not accessible (or less prioritized) to the new generation of engineers providing the driver circuits for a new technology. This went unnoticed until the first camera shots of a PWM lit environment caused troubles, leading (history repeats itself) to special equipment for medical and sports lighting and areas where high end camera application (especially moving camera application) was a requirement.

Now, again, the flicker discussion ended up in "120 Hz is acceptable", as, for example, George Zisses showed in his excellent article in LpR 53, Jan/Feb 2016, based on published, commonly accepted and applicable standards. Doing so gets the flicker out of the well perceivable range for most of the individuals. However, the main research and argumentation, not just in this article, is focused on visible perception, ignoring the known facts about OMT and the eyestrain health issues connected to long-term exposure to flickering light.

Most of the used material is based on the implicit assumption that what cannot be perceived should not cause any harm. Science needed to readjust more than once from an assumption of this kind, just look at x-rays and radioactivity.

**With lighting, the assumption made by the standards sounds correct in the first place, but this is possibly not sufficient for responsible persons and organizations:**

- There is no proof available that flicker above the said 120 Hz is harmless
- Only a little research is available concerning long term effects, and what is available was performed specifically with fluorescent lights, that have a totally different, and possibly less harmful, flicker characteristics than today's LED lighting uses

## Poor Research Coverage and Poor Results Reception

Regarding the poor research coverage of long term effects, there is one prominent investigation concerning mid to longer term effects available, that was part of the sick building research in the late 1980's, conducted by Wilkinson et al. It was focused on 100 Hz modulation [1]. It showed that a switch from a longer exposure (multiple month) with substantially modulated light (60% modulation) to low modulated light (6% @100 Hz) reduces headaches and eyestrain immediately (within a few weeks). These results are statistically significant. Most of the lighting industry ignored the results, as the opposite effect (increased eyestrain and headaches), could not be shown within four weeks of exposure that the research campaign allowed for.

On top of the limited knowledge that eases the notion "there is no effect where there is no proof of an effect", there are some hints that flicker with higher frequencies has immediate effects on some embedded mechanisms of our eye.

### Hints of Flicker Effects on Visual Performance:

- The focusing of the eye changes slightly with the frequency applied up to 300 Hz [4]
- The ability to separate fine structures is reduced with flicker up to above 300 [3]
- The visual nerve follows intensity frequencies applied up to 200 Hz
- Transitional effects of flicker have been claimed to be detectable up to 800 Hz

This seems to be very high given the bio-chemical nature of the sensors, and the relatively low fusion frequency of our visual system. This raises the question of if there is any plausibility or understanding how a non-visible modulation of higher frequencies may interfere with our perception system.

Therefore it is necessary to understand our visual system that is following a layered approach. The retina cells deliver the actual "reading" to a first layer of neuronal structure, the results are delivered to a second layer, and the overall result is then passed to the brain. Now doing a little speculative work, one could expect that OMT serves a minimum of two purposes.

### Two possible purposes of OMT:

- Cross-adjusting the attenuation of the cells by scanning over the same spatial position with two adjacent cells
- Adding to the resolution by covering the space between the cells, e.g. scanning for the exact position of a transition

The trouble is that both rely on a short-term constant intensity of the light source. The relative calibration fails if the reference source changes when switching between the cells, and the detected sharp transition during the movement is superimposed by a light source that does sharp transitions by purpose. So there is a possible conflict, but it is complex in nature and the research on this has not yet developed very far.

## Searching the Safe Side

The simple question of where the edge frequency is, leads to a difficult and multidimensional answer, and possibly needs to be split

further regarding the different types of retina cells.

### Basic Conditions:

- The edge frequency of the retina cell could well be as high as 800 Hz or slightly above (that is the maximum that has been claimed to be visible in experiments)
- The receptors in our retina never work alone; they are always networked within a complex neuronal setting. So maybe the actual edge frequency is higher but basic network layer stops faster signals from propagating to the optic nerve: the edge frequency of the signals delivered to the optic nerve seems to be in the 200 Hz range, but most likely all effects above 120 Hz are locked by the underlying network from being propagated to the optic nerve
- The edge frequency for the visual cortex of the brain seems to be around 25 Hz, called fusion frequency
- The edge frequency for other parts of the brain affected by the signals from the optic nerve seems to be at or below 30 Hz, the threshold for photosensitive epilepsy

This is again proof that the eye is a fantastic optical instrument, and uses various technologies to enhance the view (some of these technologies can also backfire when it comes to visual illusions, but this is a different story).



**Figure 7:** More stringent flicker regulations are already in discussion. At Lightfair 2015, Naomi J. Miller and Brad Lehman showed in their lecture "FLICKER: Understanding the New IEEE Recommended Practice" some applications that are recognized to be very critical. However, research results that allow to determine clear limits for being on the safe side are still missing

### Two example tasks the eye performs in an astonishing way:

- Humans are able to resolve structures that are in (and seem to be somehow below) the range of the distance of the receptor cells: The performance is better than the pixilation caused by the receptor cell array imposes. This could well be related to enhancement using the micro-tremor
- Humans are able to detect structures that are based on very low luminosity differences. This is possible only if neighborhood receptor cells are exactly calibrated (and continuously recalibrated) against each other, a difficult task for biochemical photoreceptors, and also a difficult task for technical cameras: Luminosity transition structures on the edge of visibility need really advanced apparatus to be able to photograph them

Both achievements need (relatively) steady lighting situations during the scan. Changing light affects the scan results. The higher the modulation, the more they are jeopardized.

Humans are used to "looking closely" to perform specific tasks, e.g. resolving fine structures or close-to-nothing luminosity

transitions, and that technically translates to concentrating on the point, or in other words, allowing for a longer integration time of the sensor results to get rid of sensor noise, etc. But modulated light, and especially deep modulation will ruin the attempts to get reasonable results out of the OMT enhancement, and may well be a source of stress to the eye and to the brain, especially when applied for a longer time or with difficult visual tasks.

Research in the Project Prakash on blind persons that regained their sight as adults [2] showed, that the visual apparatus and object recognition ability also adopts to a quite normal view after a while as adults, but does not gain some of the more advanced abilities. This could point to the fact, that the complex analysis ability shown above is a trained one, acquired during childhood.

### Conclusions & Prospects

Short term exposure to higher frequency flicker seems to be no trouble for adults, as long as no advanced visual tasks need to be performed. There are no suggestions that frequencies above 800 Hz affect humans, but there is enough evidence that flicker up to

400 Hz is not harmless with long-term exposure. The results suggest strongly that there are negative effects like stress or wear-out to the visual apparatus. HD movie Cameras (e.g. as found in high end smartphones) show severe interference issues with flickering light at lower frequencies, very much like the old TV screens had. Pets and especially birds may suffer from flicker that is not visible to humans, but this is a different issue.

While research cannot give clear evidence about safe lower thresholds, longer term exposure to higher frequency flicker should be avoided, and especially wherever (younger) children stay for longer periods of time to make sure the possibility of interference with their later visual abilities is minimized. To stay safe, responsible manufacturers should avoid flicker below at least 400Hz for lighting that is intended to be used in offices, working zones, baby and children's rooms, kindergarten installations and screen illumination of children's toys.

The existing research is poor and many aspects of flicker are still not clear today, such as the influence of the flicker shape. More research is definitely needed to understand where the safe zone really is. ■

### References:

- [1] Wilkins A.J., I.M. Nimmo-Smith, A. Slater and L. Bedocs: Fluorescent lighting, headaches and eye-strain, *Lighting Research and Technology*, 21(1), 11-18, 1989
- [2] Pawan Sinha: Es werde Licht, *Spektrum der Wissenschaft* 18.7.2014 (partly based on Held, R. et al: The Newly Sighted Fail to Match Seen with Felt, *Nature Neuroscience* 14, p 551-553, 2011)
- [3] Lindner, Heinrich: Untersuchungen zur zeitlichen Gleichmässigkeit der Beleuchtung unter besonderer Berücksichtigung von Lichtwelligkeit, Flimmerempfindlichkeit und Sehbeschwerden bei Beleuchtung mit Gasentladungslampen, 1989, Thesis, TU Ilmenau, Germany
- [4] Jaschinski, W.: Belastungen des Sehorgans bei Bildschirmarbeit aus physiologischer Sicht. (1996) *Optometrie*, 2, S. 60-67



### LIFUD DALI, 0-10V, PWM Dimmable LED Drivers

LIFUD DALI LED driver LF-GDExxxYF(S) series and 0-10 V and PWM dimmable LF-GDExxxYF series cover the output power range 15 - 63 W, and they are ENEC, CE, GS, CB, RCM/SAA certified. And these two series are hot selling since they hit the market.

As a leading global LED driver manufacturer, LIFUD also has ZigBee, RF LED drivers available. We commit ourselves to providing customers with the most complete portfolio LED driver solutions of guaranteed reliability.

For more details please visit [www.lifud.com](http://www.lifud.com)

**LIFUD**

sales@ledfriend.com



# interlight

MOSCOW

powered by light+building

International Trade Fair for Decorative and Technical Lighting,  
Electrical Engineering, Home and Building Automation

**8 — 11 November 2016**

IEC «Expocentre», Moscow

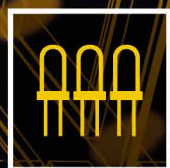

**LED Technology**

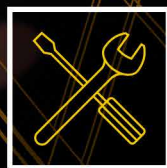
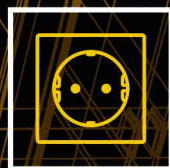
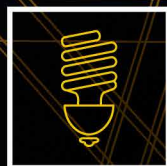
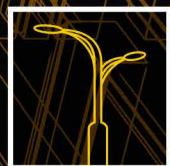

**NEW!** Business Matching

Direct negotiations with your  
potential partners in Russia



**messe frankfurt**

[www.interlight-moscow.ru](http://www.interlight-moscow.ru)

# Concepts to Overcome Lifetime Issues of LED Drivers

Lighting technology has changed significantly in recent years after a century of little to modest advancements. LED luminaires offer advancement in lower power consumption and expected life. Maggie Nadjmi, EE Product Manager at SL Power Electronics, explains why this new technology will probably not meet the life and reliability expectations if no attention is paid to the drivers and power supplies used to power LEDs. She discusses the main components affecting lifetime and how to eliminate them or design a product to still achieve the desired lifetime.

The life of an LED driver can be defined as the length of time it can operate and continue to meet its specifications. The limitation of useful life is often due to two types of components that are known and well-documented wear-out mechanisms. These components are aluminum electrolytic capacitors used for filtering/energy storage and the optocoupler for high-voltage isolation and electrical noise rejection between different voltage potentials. In this article, we will examine the essential requirements for a proper thermal design of an LED driver and selection of highly reliable electrolytic capacitors. We will also review high-performance optocouplers with photo-IC output that have employed the long life-emitting light technology.

## Aluminum Electrolytic Capacitors

Aluminum electrolytic capacitors slowly lose their electrolytes due to deterioration of the rubber seal and diffusion of the electrolyte. The loss of electrolyte causes a decrease in capacitance and an increase in ESR (Equivalent Series Resistance). This results in a decrease of holdup time and an increase of output voltage ripple and noise. Sometimes it also results in malfunction or no-start conditions of the control circuits.

The electrolyte loss depends on the temperature of the capacitor. Every 10°C reduction increases the life by a factor of 2, according to the Arrhenius Law (Figure 1). The graph shown is for 10,000 hour,

105°C rated capacitors. Capacitors are available with rated life up to 12,000 hours at 105°C and 5,000 hours rated life at 125°C, which equals 20,000 hours at 105°C. However, capacitor manufacturers do put an upper limit of 15 years (130,000 hrs) on the capacitor's life.

The temperature of the capacitor is the sum of the system's ambient operating conditions and the temperature rise of the power supply itself. This raises the temperature near the capacitors and the capacitor's internal heating due to ripple current. The system's ambient operating conditions are determined by the particular application. The temperature rise of the power supply can be derived

**Figure 1:**  
Capacitor life vs.  
temperature

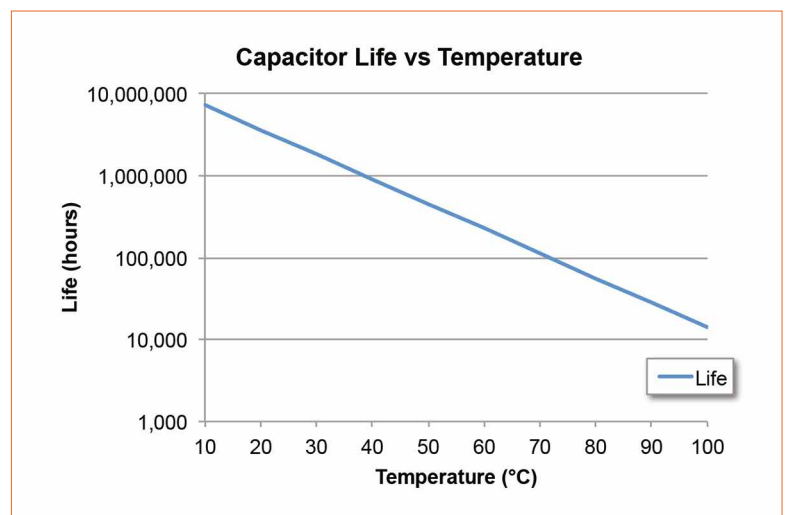

from the power supply's efficiency curve and the surface area of the power supply. The capacitor's rated ripple current is already factored into the capacitor's life specification. For that reason, as long as the capacitor is operated at the same or lower than the rated ripple current, it can be ignored.

### Design Measures to Improve E-Cap Lifetime

Design measures can mitigate the effects of temperature by prudent thermal management. One important measure is the location of the capacitor to reduce the impact of heat from surrounding components by radiation. Another important design consideration is providing a suitable path for thermal conduction, including applying appropriate thermal interface material of high thermal conductivity and heat sink at appropriate locations. It is also important to avoid placing heat

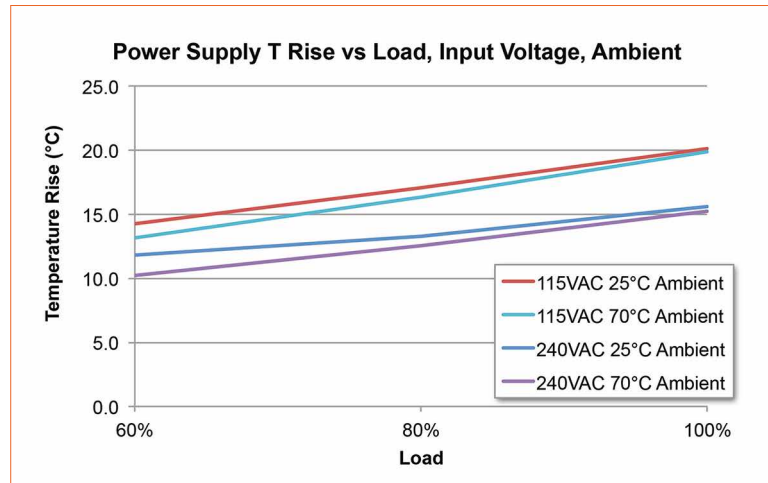

Figure 2: Power supply  $T_{Rise}$  vs. load, input voltage, ambient

components on the reverse side of the circuit board (under the capacitor).

The temperature rise of a typical 130 W power supply that measures 5x3x1.5 inches with convection cooling is shown in Figure 2. Offering some form of conduction cooling to a base plate or a fan to provide airflow can reduce the temperature rise of the power supply.

The life of a fan is often stated in terms of the L10 life expectancy. L10 specifically refers to the amount of time it takes for 10% of a group of fans to fail. The L10 life is often in the 60-80,000-hour range and is almost entirely based on the bearing system, the lubrication used, and on the ambient temperature. However, the temperature effect is less pronounced than that of aluminum electrolytic capacitors [1].

## FACT BOX

### Constructive Measures to Improve Lifetime of LED Drivers:

- Change the slotted heat-sinks to solid ones to provide more contact area between the heat-sinks and the cold plate (Figure I)
- Use thermally conducted material to bond the large magnetic parts, such as the transformer and the PFC inductor, to the solid heat-sinks. This cools them and lowers the temperature of the surrounding components
- Change all the electrolytic caps to 105°C or a higher rating, in some cases to 125°C
- Attach a cold plate to maximize the heat transfer from the cold plate to the customer chassis (Figure II)
- Submit this information to the appropriate regulatory agency to register the conduction cooling as a part of the LED fixture



Figure I: Use solid heat-sinks to add more contact area with cold plate

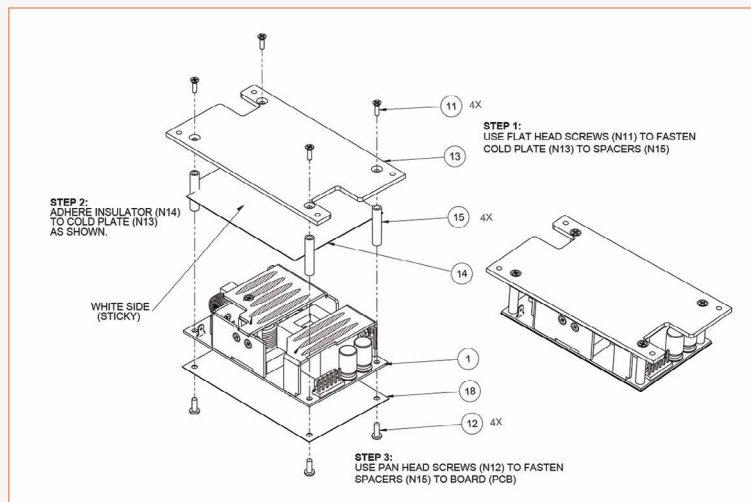

Figure II: How to attach cold plate to maximize heat transfer

When the power supply uses 10,000 hour life-rated 105°C capacitors, the capacitor life exceeds the life of any available fan. This eliminates the need for a fan. SL Power's LB240 power supply family with 130 watts of conduction power at 70C is an example of such a power supply with e-caps rated at a minimum of 10,000 hours at 105°C. The power supply is packaged in industry standard 3x5 size and has an on-board filter to meet the EN55015 EMI class B.

If fan or convection cooling is not possible and the lighting fixture has a metal chassis, the better alternative is conduction. In order to convert a convection-cooled power supply to a conduction-cooled one, the required minimum to provide a functional and safe alternative is to transfer the heat from the power supply to a metal chassis. These steps are highly recommended and if not followed, the outcome will result in a short life of components, especially for electrolytic capacitors.

## Optocouplers

Optocouplers are commonly employed in a number of different applications, including power supplies and LED drivers. However, there are still concerns regarding the optocoupler operating lifetime since LED light output power decreases over time. To understand the steps that are taken to mitigate this concern, it is important to examine the process that one industry leader in optocouplers uses to predict the LED reliability stress data under accelerated conditions.

To project expected LED lifetime performance, the Black Model, (a generally accepted empirical model developed at the end of the 1960s by J.R. Black) is used to estimate the mean-time-to-failure (MTTF) of wire associated with electro-migration. This analysis provides designers with greater confidence and design flexibility so they can specify the most appropriate LED forward input

current for their applications. An Acceleration Factor (AF) based on the Black Model can be used to correlate the actual HTOL stress test data points. These are taken at elevated temperatures and stress levels in short periods of time to the expected lifetime, according to the actual application and operating conditions of the optocoupler.

To understand the elements of optocouplers, let's review the structure of such a component. It uses an LED to transmit digital or analog information across an isolation (or insulation) barrier (often just an air gap). On the other side of the barrier is a light-sensing detector that converts the optical signal back into an electrical signal. Designers can set an input current-limiting resistor that defines a recommended input drive current (IF) to the LED to produce the desired light output. However, the optocoupler's LED quantum efficiency (total photons per electron of input current) decreases over time due to thermal and electrical stressing of the LED PN junction. A stress testing is performed to determine LED reliability for periods of continuous operation up to 10,000 hours for the various LED types used in different models of their optocouplers.

One of the stress tests, a High Temperature Operating Life (HTOL) test, is performed with the LED operating at 125°C and a continuous  $I_f$  of 20 mA. The Current Transfer Ratio (CTR) is an electrical parameter usually specified for an optocoupler. CTR is defined as the ratio of the output collector current (IC) caused by the light detected by the photodiode to the forward LED input current (IF) that generates the light, and is denoted as a percentage. Designers can use the change in CTR over time to gauge the degree of LED reliability.

### Current Transfer Ratio:

$$CTR = (IC/IF) \times 100\%$$

The input current and temperature cause heat stress in the LED crystalline structure. Thus, even though IF stays constant, the light output from the LED decreases over time. The photodiode's IC and CTR will thus decrease. At each pre-determined point of stress test hours (168, 500, 1000 hours, etc.), IC is measured, and the CTR is calculated. Then, LED lifetime performance is plotted using this collection of data points to show the change in CTR versus the number of hours that the stress test runs.

## LED Types in Optocouplers

The LEDs in optocouplers are fabricated from either Aluminum Gallium Arsenide (AlGaAs) type 1 and type 2, or Gallium Arsenide Phosphide (GaAsP). Type 1 AlGaAs LEDs are mainly used in optocoupler product families of wide-body 400 mil DIP-8 and 500 mil DIP-10 packages that house digital optocouplers, isolation amplifiers, gate drivers and IPM drivers. Type 2 AlGaAs LEDs are mainly used in optocoupler families that handle high-speed digital signals and low-power 10 Mbit/s digital optocouplers. Lastly, the GaAsP LEDs are used in a broad range of optocouplers, from digital optocouplers, analog optocouplers, gate drivers for intelligent power management and many other applications.

Each LED type employs a different manufacturing process (diffusion type or epitaxial growth), and different doping content concentration. This allows the LED designer to customize the LED light output power versus current flow to address the different speed and power performance requirements of the optocoupler. Among the three different LED types, GaAsP-based LEDs are the most mature, but have the lowest light output power, while AlGaAs type 1 offers the highest light output power. This allows AlGaAs type 1 LEDs to be used in the more stringent isolation applications that require high creepage/clearance distances

inside the optocoupler package. An AlGaAs type 2 LED has a performance level that falls between the other two LED types and can be used in a wide range of applications that require speed or power performance. All three LED types have similar characteristics, with < 10% loss from the original CTR value after 30 field years of typical operation conditions.

In general, there are three basic factors to consider to maximize the optocoupler LED operating lifetime:

- Operate the LED at a lower IF
- Operate at lower duty cycle (less than 100%)
- Operate at a temperature of less than 125°C

## Conclusions

Electrolytic capacitors and high-performance optocouplers are critical components in LED driver design and because of this, their reliability can have an outsized impact on the overall product lifetime. By managing the complete thermal characteristics of the design, optimizing the selected cooling mode (convection or conduction) of the power supply based on end use requirements, and reviewing stress test data to select optocouplers compatible with given parameters to assure the highest MTTF, designers can maximize LED reliability and the long life for their products. ■

## References:

- [1] [http://www.nmbtc.com/fans/white-papers/fans\\_ball\\_vs\\_sleeve.html](http://www.nmbtc.com/fans/white-papers/fans_ball_vs_sleeve.html)

RUSALOX
COOL SOLUTION FOR HOT APPLICATIONS

HIGH THERMAL CONDUCTIVITY  
ALUMINIUM OXIDE PCB

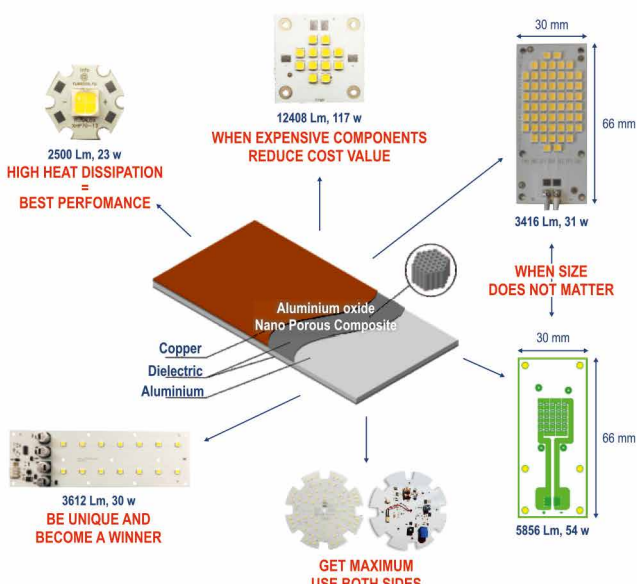



LLC. "RUSALOX" 125124, Moscow, Russia, 1st street Yamskogo polya, 9/13, office 304  
 Phone: +7(499) 557-0065; Mob.: +7(964) 587-1110; +7(968) 642-7328; mao@rusalox.ru mmn@rusalox.ru



Visit us at LpS in Bregenz booth A16  
[www.topsilglobal.com](http://www.topsilglobal.com)

## TOPSILGLOBAL

Excellence in processing of silicone & TPE

Did you know that silicone is the most durable of all optical materials, when it comes to light transmittance stability? Other advantages of optical silicone are:

- Outstanding heat aging and UV resistance
- Very accurate mould surface reproduction
- Possibility of combining a lens with a sealing in one part
- and many more...

Topsil Global has more than 25 years of experience in silicone processing

- Long lasting cooperation with world leading lighting companies
- Unique experience in optical silicone processing, since 2012
- Support at every stage of product development

# TM-30 or the Quest for New Metrics to Measure Light Color Quality

As the lighting industry's need for an unambiguous measure of lighting color quality becomes more urgent, the TM-30 test method put forward by the Illumination Engineering Society of America (IES) is one approach that could offer a solution. Arno Grabher-Meyer, Editor in Chief at LED professional gives a quick status overview.

The emergence of energy-saving lighting has galvanized debates about methods of expressing color-quality. LED lighting is the latest and arguably most disruptive of the new technologies to enter general use, offering users tremendously expanded selections of effects and tones.

The Color Rendering Index (CRI Ra), calculated using a method defined by the International Committee on Illumination (CIE), has been the lighting industry's reference for many years. But although it is easy to understand, it can give confusing results. It is possible for some lamps to gain a high CRI after testing yet deliver illumination that is well below expectations. The need for a new standard test method capable of generating an unambiguous expression of color quality has become urgent.

## The Limits of CRI

The standard method for calculating CRI uses eight sample colors. These are deemed to be representative of most objects, but in fact are medium-chroma pastel colors (Figure 1). To perform the test, the Correlated Color Temperature (CCT) of the test source is first determined. A reference source of the same CCT is then calculated. The eight standard samples are then illuminated by the test source and the reference source, and their coordinates are found on the CIE Y-U-V color space. The distance between the pairs of coordinates for each sample ( $E_i$ ) is then calculated and used to generate eight results ( $R_i$ ) expressing the fidelity for each sample. The arithmetic mean of these values is then calculated to generate the CRI as the average color rendering index (Ra).

One of the strengths of the CRI is its simplicity. As a one-number metric that expresses the quality of a lamp in terms of its closeness to daylight, it is relatively easy to measure and easy for end users to understand.

On the other hand, its simplicity can lead to ambiguity. Because the index is an average with reference to only eight colors, it is possible for a high-scoring lamp to give poor results with other colors; particularly saturated colors (red, yellow, green, blue), as these are not included in the test samples. Accurate rendering of saturated colors, and red in particular, can be important in situations where vibrant effects are desirable, such as merchandising clothes or produce. Faithful rendition of red colors is also important for accurate representation of skin tones and for lighting in health centers and hospitals.

Some LED-lighting manufacturers publish the red-rendering (R9) performance of their products in addition to CRI, and indeed, Energy Star requires qualifying products to achieve a minimum R9 greater than zero and CRI of 80 although the R9 value is often not communicated.

More accurate is the CRI according to DIN 6169. It adds four saturated colors, and two colors are representatives of well-known

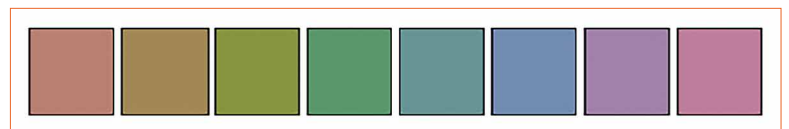

**Figure 1:**  
CRI test color samples  
are pastel shades only

objects. These are usually not part of the CRI value and provide supplementary information.

Another big disadvantage of the CRI metrics is the use of the “2° standard observer” method instead of the 10° observer. In SSL products, the same CRI and CCT can lead to a completely different appearance when the 2° observer is used, even for 1SDCM binning. This becomes better when the 10° observer method is applied. Therefore Osram recently proposed to use the 10° observer system for critical applications [1, 2].

The CIE as well as the industry are well aware of the deficiencies of the CRI metrics. Several attempts to improve this system were undertaken from the beginning on. Until now, all were unsuccessful. Even for the most promising predecessor, the R96a method, no consensus could be found and the committee was dissolved in 1999.

### LED Lighting Demands Better Metrics

To win customer acceptance for new lighting technologies, vendors have had to justify the quality of the light generated by the new sources and explain how and why the effects differ from those delivered by incandescent lamps. Drawing attention to CRI has helped customers understand how to select lamps that are best suited to their needs.

As a wider variety of end users become familiar with CRI, its shortcomings are becoming more widely appreciated. LED lighting, in particular, has increased the need for urgent agreement on a more robust color-quality metric.

A wide variety of criteria influence the characteristics of light from white LEDs. These include differences between fabrication technologies, as well as various techniques for mixing RGB sources or applying phosphor correction. Moreover, these are subject to

ongoing development seeking to reduce costs and optimize productivity. As a result, the white LEDs in the market offer many different versions of “white” light. They can also be engineered to produce favorable results under simple tests such as CRI.

### CQS, GAI, TLCI - The Better Choice?

Besides the CRI, more than 25 indices [3] were proposed over time, but most of them did not become serious candidates for replacing CRI; not the Flattery Index (Judd, 1967), the Color Preference Index (Thornton, 1974), the Color Discrimination Index (Thornton, 1972) nor the Cone Surface Area (Fotios, 1997), just to name a few. However, there are also three indices that are sometimes used and published by some US and Japanese SSL manufacturers: CQS, GAI and TLCI.

The CQS method seeks to improve on CRI by standardizing a larger set of test samples including the saturated colors as well as earth colors and a standardized Skin Tone. Moreover, the CQS calculations are structured to prevent lamps that achieve very high fidelity with some colors but give poor results with others from scoring an average good enough to qualify for a high overall index. However, CQS still only tests fidelity. Its capability to describe color rendition accuracy is limited while its strength is in being a measure for color preferences.

The Gamut Area Index (GAI) is calculated by dividing the gamut area formed by the light source with the gamut area formed by the reference source using the same set of colors (R1 - R8) that are used for the color rendering index in the CIE 1976 color space. By definition, any light source with CRI of 100 will have a corresponding GAI. GAI gives information about vibrancy but not about color rendering accuracy. Like CRI, GAI on its own is no indicator of

visual preference, and a high GAI does not mean that any color is rendered more vibrant.

Sometimes, but not very often, product information includes TLCI, the Television Lighting Consistency Index. This index has been developed because with the introduction of LED, the television and film production industry recognized huge issues. While CRI and GAI are related to the “human standard observer” and the human visual apparatus continually adjusts to make colors look correct independent of the CCT, this is not the case with cameras. Therefore, TLCI refers to a kind of “standard camera” model including the knowledge about the production process and display. This renders TLCI useless as replacement for CRI.

While these metrics might be slightly better than the current CRI, any proposal has clear weaknesses. None cover all the necessary aspects to become the perfect candidate to replace CRI. No wonder that CIE hasn't found common understanding for a substitute up until now.

### TM-30 - The Way Forward?

The Illumination Engineering Society of America (IES) has suggested the new TM-30 test method, which has been designed to overcome the limitations of fidelity-based metrics such as CRI and CQS. TM-30 addresses perceived shortcomings associated with the color space, test samples, and characteristics of the reference illumination, and generates more detailed metrics that describe not only fidelity but also gamut and a color-vector graphic that helps end users anticipate the lamp's performance in their intended application.

TM-30 uses a more up-to-date color space than the well-known CIE U-V-W two-dimensional space. IES argues that U-V-W does not provide an accurate, uniform representation of three-dimensional color in terms of lightness, chroma and hue.

**Figure 2:**  
The TM-30 Color Evaluation Samples (CES) consists of 99 different colors

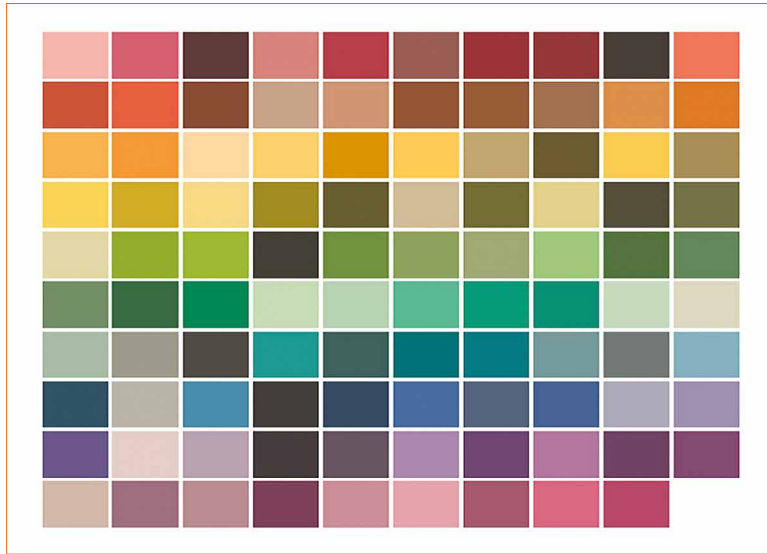

**Figure 3:**  
TM-30 smooths the reference source continuum by blending between 4500 K to 5500 K

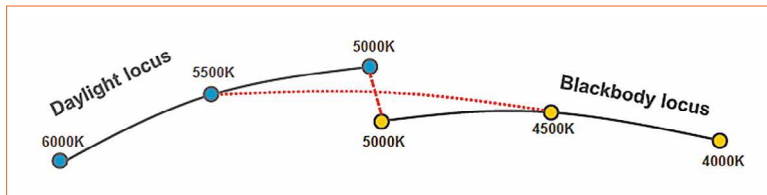

Instead, the TM-30 test method uses the three-dimensional CIE-CAM02-UCS uniform color space. This is a state-of-the-art color space that has more uniform characteristics than the older U-V-W color space, and is better suited to calculating color differences.

**Extra color samples**

TM-30 also specifies a much larger set of color samples than either the CRI or CQS test methods. In fact, 99 Color Evaluation Samples (CES) have been selected, with spectral properties representative of real objects such as paints, textiles, skin tones and inks. Figure 2 shows the 99 samples. In addition to having been chosen to give uniform coverage of the color space, they have also been selected based on their reflectance properties so as to minimize differences in sensitivity for individual wavelengths. This helps to eliminate naturally occurring sample-related bias. The larger set of samples, with insistence on wavelength uniformity, also helps to prevent selective optimization: that is, deliberately fine-tuning the light source to prioritize a high test score in preference to real-world performance.

**Blend of reference sources**

As with the CRI test method, TM-30 uses a combination of reference sources with characteristics along the daylight locus at CCT of 5000 K and above, and along the blackbody locus at 5000 K and below. As figure 3 shows, there is a significant difference in the two loci of the two reference sources around 5000 K. TM-30 blends reference sources in the 4500-5500 K range to give a smoother transition that is more in keeping with modern color-tunable sources.

**A measure beyond fidelity**

Using results from the 99 color samples, and the latest color space and calculation engine, the TM-30 test method generates a value for fidelity,  $R_f$ , as the arithmetic mean of the 99  $R_i$  values. This is similar to the way CRI is calculated, although the larger and better-selected range of samples is intended to ensure that the TM-30  $R_f$  is a more accurate measure of fidelity than the  $R_a$  value of CRI.

To provide a more in-depth assessment of color quality, TM-30 also expresses the increase or decrease in chroma when testing

the 99 color evaluation samples. This is the gamut index,  $R_g$ , and is calculated from a color vector graphic that is generated by plotting average chromaticity coordinates in each of 16 hue bins that span the full range of chromaticity. This establishes two sets of 16 averaged points on the chromaticity diagram, representing the responses of the color samples both to the reference light source and the test source. Joining each set of points generates two polygons that express the color gamut for each source respectively, as shown in figure 4. Calculating the difference in area between the two polygons gives the value of  $R_g$  for the test source. The color vector diagram showing the two polygons also allows the reader to identify hues that will be more saturated - and those that will be less saturated - compared to the reference source. In bins where the test source polygon is outside the reference polygon, saturation will be greater.

**Plugging in the numbers**

The TM-30 technical memorandum provides access to online spreadsheets that help calculate and display the results. The results include the fidelity index,  $R_f$ , which can be up to 100 similar to the case with CRI. The gamut index,  $R_g$ , is also calculated, and can be up to 140.  $R_g$  is allowed to be greater than 100 because the test lamp can have a larger gamut than the reference.  $R_f$ , as a measure of fidelity, can only be up to 100.

The TM-30 results can also be expressed graphically. The color vector, diagram similar to that shown in figure 4, shows clearly where the test lamp has greater or lower gamut than the reference. This helps identify colors that will show an increase or decrease in chroma.

Moreover, plotting the values of  $R_f$  and  $R_g$  on a two-dimensional color rendition diagram gives a graphical representation of the lamp indices



# Prime showcase for the brightest and best

**HKTC Hong Kong International Lighting Fair (Autumn Edition) 2016** and **HKTC Hong Kong International Outdoor and Tech Light Expo 2016** together form the world's leading lighting marketplace. An exciting showplace for trends and technology, the events are organised by the Hong Kong Trade Development Council and featured 2,727 exhibitors from 35 countries and regions and attracted more than 49,000 buyers in 2015.

## Lighting industry's premier showcase

The Autumn Lighting Fair is known internationally for its wide range of offerings. Any exhibitor can find a niche in the major exhibit categories. These are:

- Commercial Lighting
- Household Lighting
- Smart Lighting & Solutions
- Trade Service & Publication
- Hall of Aurora
- LED & Green Lighting
- Testing, Certification & Inspection

## Illuminating activities

There are so many ways to learn more and expand the circle of contacts at the Autumn Lighting Fair 2016. Through seminars and forums participants can acquire market intelligence and trend insights as well as technology updates while social activities such as the Networking Reception allow industry players to make important new contacts.



### • HKTC Hong Kong International Lighting Fair (Autumn Edition) 2016

Date: 27-30 October 2016

Venue: Hong Kong Convention and Exhibition Centre



### **First-time overseas buyers are entitled to exclusive travel incentive.**

Pre-registration is required. Please contact HKTDC at Tel: (852) 2240 4235, Fax: (852) 2169 9770, or Email: [hklighting.visitor@hktdc.org](mailto:hklighting.visitor@hktdc.org) for details.

Reserve your admission badge and save HK\$100!

Web: [www.hktdc.com/ex/hklightingfairae/52](http://www.hktdc.com/ex/hklightingfairae/52)

Wap: [hktdc.com/wap/lightae/T119](http://hktdc.com/wap/lightae/T119)

App: HKTDC Mobile



## Spotlight on Outdoor and Industrial Lighting

**HKTC Hong Kong International Outdoor and Tech Light Expo** is launched this year. To test market demand, the organiser, the Hong Kong Trade Development Council, hosted the World of Outdoor Lighting & Lighting Accessories in 2015. The event featured more than 170 exhibitors and attracted more than 11,000 buyers in 2015, including Colinter from France, Crompton Greaves Ltd. from India, EpiCentre K from Ukraine, Hesham ElSewedy Trading from Saudi Arabia, Menfor Sp. z o.o. from Poland, Miite 10 from New Zealand, Plantir from Russia, Tokyo Interior Corporation from Japan, Zoomlux Lighting LLC from the UAE, as well as OBI Group Sourcing HK Ltd and REWE Far East Ltd from Hong Kong. The Expo is tightly focused. Major exhibit categories are Outdoor Lighting, Lighting Accessories, Parts & Components, Professional and Industrial Lighting, and Advertising Lighting.

## More value in concurrent events

- **HKTC Hong Kong International Outdoor and Tech Light Expo 2016**
- **Eco Expo Asia 2016 – International Trade Fair on Environmental Protection**
- **HKTC Hong Kong International Building and Hardware Fair 2016**  
Date: 26-29 October 2016    Venue: AsiaWorld-Expo, Hong Kong

**Figure 4:**  
The color vector diagram helps compare chroma performance and calculate  $R_g$

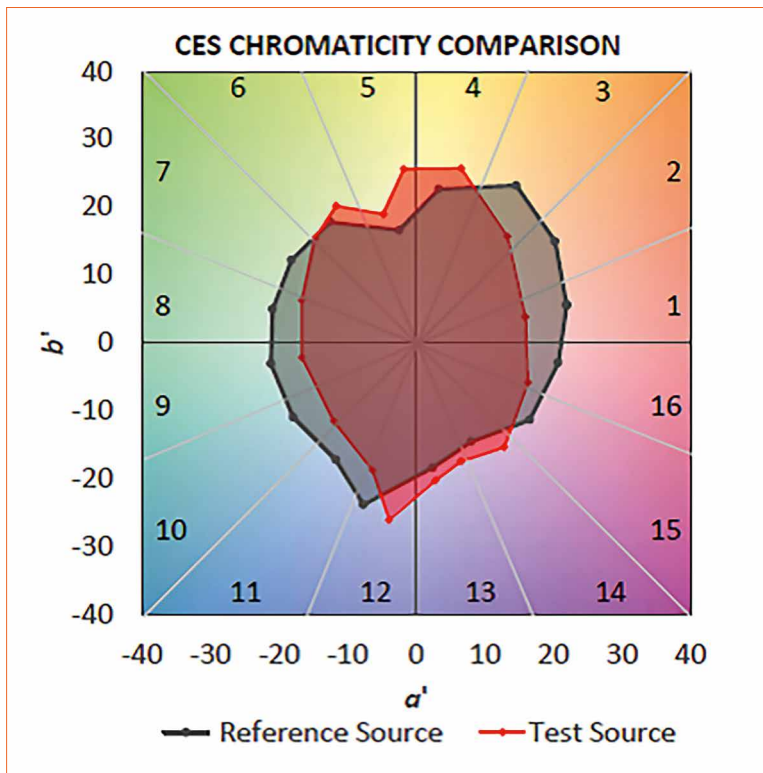

### Prospects - Change Ahead?

The IES has been busy explaining TM-30 for groups like specifiers and manufacturers of lighting equipment, since presenting a pair of introductory webinars [4] in September 2015. The method is just beginning its journey aiming to becoming a trusted industry reference. Will manufacturers embrace it? Will specifiers understand it? For manufacturers, the decision may come down to economics: whether the testing can be completed quickly and cost-effectively given the much larger number of color samples and data points, and more intensive processing of the results. Acceptance among specifiers may depend on the way manufacturers present their results. Certainly the graphics can potentially give a better idea whether a lamp will be suited to a given task.

**Figure 5:**  
Color rendition as described by TM-30 indices

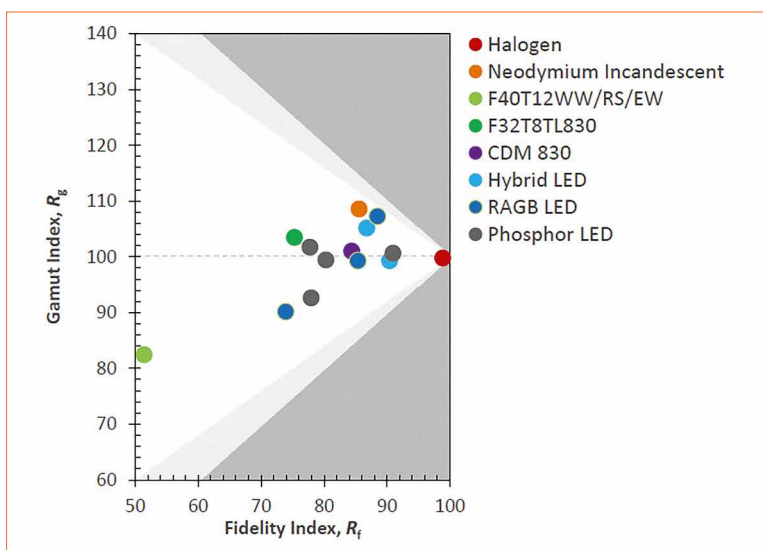

that is more descriptive than CRI yet still quite easy to understand.

Figure 5 plots  $R_f/R_g$  for sources across a variety of technologies.

We may all agree with the objectives driving TM-30. The next step could be for manufacturers to step up: start testing, and publish the results. Still the questions if CIE will finally follow the IES proposal and make TM-30 the new international standard remains: Will they refuse adoption or will the related CIE workgroup ask for some changes or further improvements? The chances for TM-30, or at least a revised version of it, to become the new international color metrics standard is better than for any predecessor, as some CIE members were also involved in the development. ■

#### Credits:

All figures are adapted from Michael Royer's (PNNL) and Kevin Houser's (Penn State University) DOE+IES Webinar | September 15, 2015 presentation "Understanding and Applying TM-30-15", and from Michael Royer's (PNNL), Aurelien David's (Soraa, Inc.) and Lorne Whitehead's (University of British Columbia) DOE+IES Webinar | September 22, 2015 presentation "A Technical Discussion of IES TM-30-15"

#### References:

- [1] Arno Grabher-Meyer, Light + Building Post Show Report: The Six Most Noteworthy Observations, LED professional Review 55 - May/June 2016, pg. 36
- [2] [https://www.led-professional.com/products/leds\\_led\\_modules/world-premiere-osram-presents-10deg-binning-for-white-leds-solieriq-s-13-gen-3-at-first](https://www.led-professional.com/products/leds_led_modules/world-premiere-osram-presents-10deg-binning-for-white-leds-solieriq-s-13-gen-3-at-first)
- [3] <http://energy.gov/eere/ssl/webinar-understanding-and-applying-tm-30-15>
- [4] <http://energy.gov/eere/ssl/downloads/webinar-technical-discussion-tm-30-15>



# ILLUMINOTRONICA

HUMAN CENTRIC LIGHTING TECHNOLOGIES

PADUA - ITALY 6/8 OCTOBER 2016

## MEET SMART TECHNOLOGIES!



### AT HOME

Home Automation - Security - System Integration  
Audio/Video - Smart Lighting - Energy Management



### IN DESIGN

Lighting Design - Human Centric Lighting - Indoor  
Lighting Made in Italy - Light & Well-being



### IN THE CITY

Smart Lighting - Outdoor - Energy Efficient  
Integrated Solutions - Smart City



### IN PRACTICE

E-Lab - Electric and Electronic equipment  
Demo Areas - Test & Measurement - Start-Up

## ILLUMINOTRONICA

shows integrated technologies and solutions for lighting,  
home automation and security applications for the smart home

The trade fair is dedicated to those who produce,  
create, utilize, manage and install lighting

The know-how of LED and its emission, power supply,  
amplification, management. For those who want  
to use and "model" LEDs, for any application

PROMOTED BY:

Assodel  
Italian Association of Electronics Clusters



Hut Group  
Home & Urban Technologies



IN PARTNERSHIP WITH:

CasaClima



CONTACTS:

Ph. +39 02 210.111.236  
segreteria@illuminotronica.it



# High-End White Light Sources Fiber Optics Technology for Medical Applications

Often technologies that are too expensive for the mass market at the beginning are already adopted in medical applications. When reaching a certain level of maturity, costs usually become more reasonable and adaptations for the consumer market begins. Holger Laabs, Oliver Mehl and Henning Rehn from Osram GmbH present a light source technology and its prerequisites for fiber optics that could become one of these technologies.

Over 170 years ago the Swiss physicist Jean-Daniel Colladon set the foundation for modern fiber optics. He demonstrated optical experimental wave guiding through total internal reflection in a water jet illuminated by the sun [1].

Today there are many applications of optical fibers. Besides single fibers with certain spatial profiles of the index of refraction (e.g. step- and gradient index fibers) there are also structured fibers. These structures can be either perpendicular to the fiber axis (e.g. photonic crystal fiber) or along the fiber axis (e.g. fiber with Bragg grating). Single fibers can be clustered to fiber bundles, in a regular or irregular arrangement; or they come as ridged waveguides in macroscopic dimensions. As an alternative to large diameter fiber bundles, flexible, liquid filled fibers are available as well.

New lighting technologies enable fiber light sources with higher efficiency and lifetime and smaller fiber diameters. These are especially useful for endoscopy and industrial metrology.

## Uses of Optical Fibers

Fibers for communication are ubiquitous with data rates up to 100 Tbit/s from a single fiber [2]. Not only high data rates but also high optical power can be transmitted through fibers; fiber optical cables for high power laser are commercially available for radiant power up to e.g. 20 kW [3].

For bio photonics and medicine there are well known applications in microscopy, endoscopy and fiber-illuminated headlamps. More recently new applications in photodynamic therapy and optogenetics are enabled by optical fiber technology.

Instead of using fibers for the transmission of data or optical radiation, fibers can also serve as sensing devices for things like mechanical stress, vibrations and temperature. For these applications signals of optical scattering processes (Rayleigh-, Brillouin- and Raman scattering) are either measured along the full fiber in conjunction with the run time measurement, or locally with fiber Bragg gratings [4].

## Changes in Lighting Technology

In many applications lighting technology is changing from incandescent, halogen or discharge lamps towards LED and laser technology. This can be combined with a digitalization and cross-linking of lighting control gear. OSRAM offers various light sources, like halogen lamps, LED- and laser light sources for the medical market. In the following we present the technology of newly developed light sources for fiber illumination.

Endoscopy is a good example to illustrate the technological advancement in light sources. First endoscopes were made with miniature incandescent lamps at the distal end. With the introduction of fibers in combination with cold light the light source was moved out of the body in order to reduce the thermal load onto the tissue. Today the light is generated with modern type xenon lamps, LED- or laser light sources and is guided by a system of fibers to the distal end of the endoscope.



**Figure 1:** Examples for conventional fiber optics light sources: MR16 64607 50 W 8 V, XBO R 300 W/60 C OFR, HXP R 120 W/45 C VIS

### Coupling Light into Fibers

Based on fundamental laws of Étendue preservation, the maximum flux of light that can be coupled into a fiber can be estimated by the product:

$$\phi = L_{source} \cdot U_F$$

with  $L_{source}$  being the luminance of the light source and  $U_F$  the Étendue of the fiber:

$$U_F = (\pi \cdot r \cdot NA)^2$$

with fiber core radius  $r$  and numerical aperture  $NA$ .

Due to the small Étendue of used fibers, light sources with high luminance are required to flow for high luminous flux of the transmitted light.

### Traditional Light Sources for Fiber Illumination

Traditional light sources for fiber applications include halogen lamps, xenon discharge lamps and mercury discharge lamps (Figure 1).

These light sources are employed according to the special requirements in microscopy, for example, in cold light sources, endoscopy, boroscopy, medical head lamps, or for point curing of glues. The advantage of traditional light sources lie in their spectral characteristics, their high luminance and sometimes in their favorable price/performance ratios. A disadvantage is the limited lifetime and the need for regular lamp replacement. Lamps used for fiber light applications usually have a

reflector that collects light from the burner and focuses it onto the end of a fiber or optical systems making the application of lamps rather easy.

### LED Technology

Driven by the limited lifetime of traditional lamps as well as advancements in LED technology, in particular luminance, light emitting diodes are becoming suitable light sources for fiber coupling.

In contrast to traditional light sources LEDs radiate only into one hemisphere. This enables the use of lenses instead of (elliptical) reflectors. Lens systems can be corrected for aberrations allowing for high coupling efficiency in Étendue limited applications.

Due to demanding luminance requirements only cold white LEDs with low color rendering where employed in the beginning of fiber sources with LED technology. Many applications require warm white light with high color rendering, but high luminance in conjunction with superior color rendering is

difficult to achieve with a single LED source. One solution is spectral multiplexing of LEDs with different colors. The LED spectra can be optimized to result in high color rendering indices (Ra=80-95). Moreover, control of individual LED channels allow for CCT (correlated color temperature) tuning between 3000 K and 8000 K.

LEDs can either be placed very close to each other or, for highest illuminance; their light is combined with dichroitic mirrors (Figure 2) resulting in a luminance of up to 280 cd/mm<sup>2</sup>.

### PHASER Technology

Besides scaling just luminous light flux (e.g. by increasing the area of the source in two dimensions) many applications require higher luminance (more flux from a small area into a small solid angle) as explained earlier. Such an Étendue-limited application is fiber coupling where higher luminance results in more luminous flux from a small fiber with small numerical aperture.

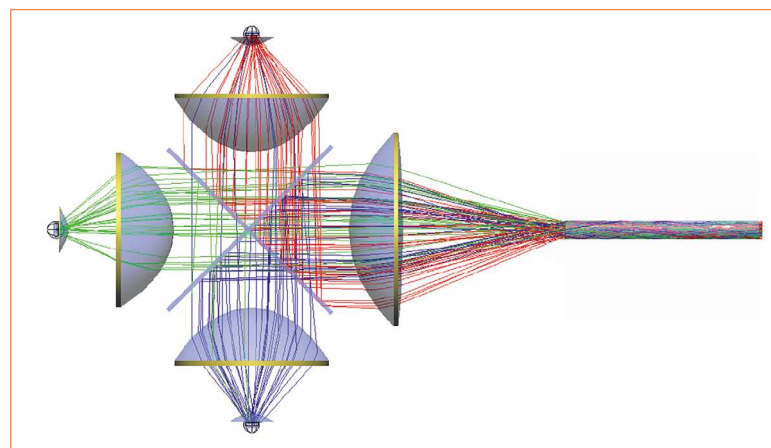

**Figure 2:** Model of a RGB LED light source for fiber applications. The light of each individual LED is collimated, combined with a dichroitic mirror and refocused into a fiber. With a color management system the target color coordinates can be addressed and maintained over time

**Figure 4:**  
Comparison of spectra from different fiber light sources

High power white LEDs allow for luminances between 100 and 300 cd/mm<sup>2</sup> and are based on blue InGaN chips [5], which excite a broadband phosphor in the yellow spectral range [6]. However, even at 300 cd/mm<sup>2</sup> only 25 lm of white light can be coupled into a fiber with a core diameter of 500 μm and a numerical aperture of 0.37. If higher luminous fluxes are required, other light sources with luminances exceeding 300 cd/mm<sup>2</sup> have to be employed. Such a light source may still use a broadband yellow phosphor, but a higher pump power density has to be accomplished at the luminescent material. The increase in pump power density is enabled by blue InGaN semiconductor lasers. Their very small beam parameter product M2 or Étendue allows for a small excitation area on the phosphor even at high levels of optical power [7]: e.g. 10 W of optical pump power of the laser incident onto a round area of 500 μm results in a power density of 50 W/mm<sup>2</sup>. The acronym PHASER for this laser - phosphor technology results from a combination of "PHosphor" and "LASER". Application areas are video projection, fiber based medical applications [9] or automotive laser light [10].

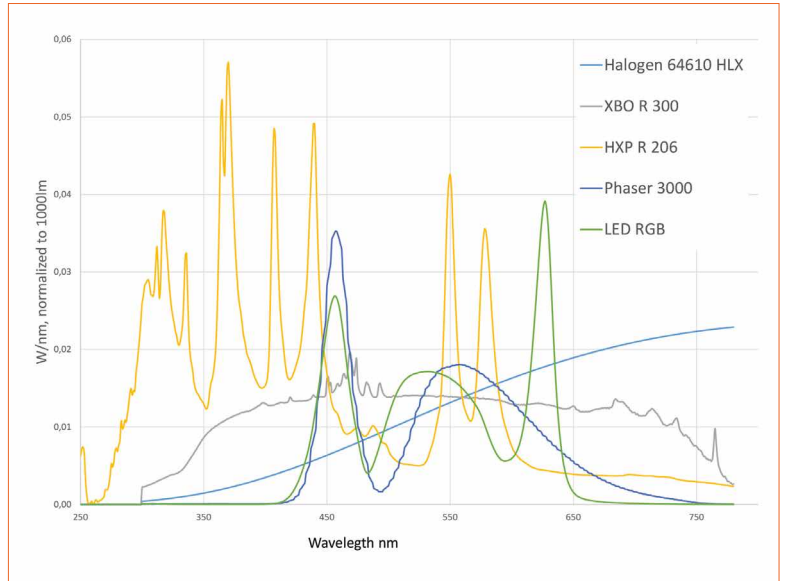

**Table 1:**  
Fiber light source properties overview

Source	Electrical power (W)	Peak luminance (cd/mm <sup>2</sup> )	Optical efficiency source to aperture D5 mm ±22°	Color rendering index Ra	Lifetime (h)
Halogen 64615 HLX	75	30	10%	100	50
HXP R 120	120	1000	29%	58	2000
XBO R 300	300	1000	52%	97	1000
LED cold white	20	200	78%	70	~30000
LED system RGB	33	280	66%	80..95	~30000
PHASER 3000	180	500	30%	70	~30000
PHASER 500	40	3700	100%	65..70	~30000

### Fiber Light Sources with PHASER Technology

Today, light sources based on PHASER technology have started to replace xenon lamps. For example, the ITOS PHASER 3000 substitutes a 300 W xenon lamp, but with a power consumption of only 180 W and a life time up to 30 khrs. PHASER systems can be engineered to a modular system, hence enabling the mixing of additional wavelengths for supporting special image processing modes. The additional wavelengths are quickly switchable in comparison to mechanical filter wheels allowing new modes of operation in various applications. As an additional benefit, PHASER light sources do

not emit ultraviolet or infrared radiation rendering additional filters known from conventional light sources obsolete.

The ITOS PHASER 3000 is designed for a fiber bundle diameter of 4.8 mm and a numerical aperture of 0.37 (+/- 22°), but can also be adapted to other fibers.

### Technology Comparison

In fiber light applications, semiconductor-based light sources are increasingly succeeding. Table 1 compares properties of different light sources. LED and PHASER light sources easily

achieve the performance of halogen and discharge lamps but have a much longer lifetime. The power required for generating the light is much reduced and system efficiency is increased. The spectral characteristics of the different light sources vary strongly as shown in figure 4 and need to be considered based on the intended application.

For camera-based applications (e.g. most of medical endoscopy) the perceived difference in color reproduction can be overcome by white balancing and image processing. In other applications where the light is detected by the

# PHOTOPTICS 2017

5<sup>th</sup> International Conference on Photonics, Optics and Laser Technology

PORTO, PORTUGAL | 27 FEBRUARY - 1 MARCH, 2017

Conference Areas

1. OPTICS

2. PHOTONICS

3. LASERS

REGULAR PAPER SUBMISSION: **SEPTEMBER 22, 2016**

**Conference Chair**

Paulo A. Ribeiro  
*CEFITEC/FCT/UNL, Portugal*

**Program Chair**

Maria Raposo  
*CEFITEC, FCT/UNL, Portugal*

**Keynote Lecture**

José Luís Santos  
*Universidade do Porto, Portugal*



MORE INFORMATION AT: [WWW.PHOTOPTICS.ORG](http://WWW.PHOTOPTICS.ORG)

SPONSORED BY:



INSTICC IS MEMBER OF:



LOGISTICS PARTNER:



PAPERS WILL BE AVAILABLE AT:



IN COOPERATION WITH:



PROCEEDINGS WILL BE SUBMITTED FOR INDEXATION BY:



Scan and connect to:  
[www.photoptics.org](http://www.photoptics.org)

**Figure 5:**  
ITOS PHASER  
500 technology  
demonstrator with  
370 lm out of a fiber  
(400 $\mu$ m diameter  
and NA 0.5) recently  
reached record  
luminance levels  
for fiber optics light  
sources



human eye (microscopy or surgery), the spectral properties can be enhanced - as mentioned before - either by addition of wavelengths or by spectral filtering with customized transmission filters.

### Outlook

PHASER technology already allows for luminance levels beyond 5000 cd/mm<sup>2</sup> in the lab environment and is therefore comparable to highest pressure discharge lamps [12].

A recent technology demonstration yields 370 lm white light flux in a 400  $\mu$ m fiber core diameter and a numerical aperture of 0.5, corresponding to a luminance of 3700 cd/mm<sup>2</sup> (Figure. 5).

For medical applications with flexible endoscopy the required area for illumination can be significantly reduced. A fiber with only 200  $\mu$ m, for example, and a numerical aperture of 0.5 will be able to transmit a luminous flux over 100 lm if a PHASER light source with 5000 cd/mm<sup>2</sup> is employed. By choosing phosphors in combination with filtering or wavelength multiplexing the spectral power density can be tailored to the requirements of specific applications. ■

### References:

- [1] Wikipedia: Jean-Daniel Colladon
- [2] Jeff Hecht, Ultrafast fiber optics set new speed record, NewScientist, 2809, April 2011
- [3] www.optoskand.se
- [4] J. Wallace, Fibers for sensing extend their reach, Laser Focus World, Jan 2016, 83ff
- [5] Wikipedia: Indium gallium nitride
- [6] OSRAM product catalog: LED OSRAM OSTAR headlamp, www.osram-os.com
- [7] Wikipedia: Beam parameter product
- [8] OSRAM Ostar Projection Power datasheet, Version 1.11, August 2015
- [9] OSRAM product catalogue: ITOS PHASER 3000
- [10] [http://www.osram.com/osram\\_com/news-and-knowledge/automotive-special/trends-in-automotive-lighting/laser-light-new-headlight-technology/lasertechnology-functionality-and-advantages](http://www.osram.com/osram_com/news-and-knowledge/automotive-special/trends-in-automotive-lighting/laser-light-new-headlight-technology/lasertechnology-functionality-and-advantages)
- [11] [www.osram.com/osram\\_com/products/led-technology/specialty-lighting/led-modules/itos/itos-phaser-3000/](http://www.osram.com/osram_com/products/led-technology/specialty-lighting/led-modules/itos/itos-phaser-3000/)
- [12] Wikipedia: Luminance



**CIOE**

CHINA INTERNATIONAL  
**OPTOELECTRONIC**  
EXPO



# A 360° VIEW OF THE LED INDUSTRY

 **LED Techina 2016**

- *Materials & Components*
- *Lighting & Display*
- *Packaging & Modules*
- *Manufacturing & Testing Equipments*

**September 6-9, 2016**

Shenzhen Convention & Exhibition Center • China

CONCURRENT EVENT



**CHINA SAPPHIRE  
TECHNOLOGY & TOUCH SCREEN EXPO**



CONCURRENT CONFERENCE

2<sup>nd</sup> International Forum

SAPPHIRE MARKET  
AND TECHNOLOGIES 2016



[WWW.CIOE.CN](http://WWW.CIOE.CN)

# LED Lamps Recycling Technology for a Circular Economy

While having a long propagated lifetime, LED lighting products, especially lamps, have a foreseeable end of life. And since they contain many valuable elements they practically beg to be recycled. However, like other highly integrated electronics products recycling is not a simple task. Andrea Gassmann, Jörg Zimmermann, Roland Gauß, Rudolf Stauber and Oliver Gutfleisch from the Fraunhofer Project Group Materials Recycling and Resource Strategies IWKS and the Technische Universität Darmstadt Institute for Materials Science respectively, present and discuss a method that could open the way to successful recirculation of precious components and materials.

The victory of LED technology over conventional technologies seems to be confirmed for many applications. After having taken over the backlighting market for flat panel displays, LEDs also entered the general lighting market and penetrated all segments from private homes and industry facilities to streetlights. The growing number of LED lamps and especially their integrated design that often does not allow for an easy exchange of components, raises the question of how to recycle and recover the valuable materials that are included in these lighting products. Using current e-waste recycling techniques, LED-specific materials, i.e. semiconductors like gallium, rare earth metals like yttrium, lanthanum or europium and precious metals, would be dissipated irrecoverably.

This article reviews the current trends of the lighting market and the implications on future lamp recycling. It will be shown that the application of smart separation technologies is the key point for successful lamp recycling, paving the way for the development of suitable extraction procedures for the valuable materials within LEDs.

## Introduction

In order to meet today's climate targets, statutory requirements, and cost saving methods, the current lighting market is experiencing a technology revolution that affects all segments. With the key requirements of lighting equipment efficiency, long lifetime and ecological compatibility, LED technology proves to be the winner of this change. Conventional light bulbs, halogen lamps and energy saving lamps are being continuously phased out and replaced by LED-based products. In fact, this technology change is much more than a 1-to-1-replacement action. It opens up a multitude of new fields of application that could not be realized before with conventional lighting technologies. Today, the function of a state-of-the-art LED lamp is not limited to illumination only. Due to color change and dimming functionalities and the miniaturized design, LED lamps and luminaires are increasingly used as mood lighting (e.g. color change lamps, LED stripes) or decorative objects (e.g. filament LED-lamps). Meanwhile, the lighting market offers a variety of multi-functional lamps - being closer to consumer electronics than to lighting equipment - integrating speakers or WLAN repeaters. The possibility of

being able to personalize light scenes and to connect to the lamp via a tablet or mobile phone using apps is in line with the current trends towards a connected and digital life style as promoted by the smart home or smart living concepts.

Despite this development, there is yet no time scale showing when the above mentioned trends will actually reach and dominate lighting market segments like private homes, public areas, industry or transportation and shipping. But the trend towards LED lighting products cannot be denied any more. The transformation of lighting segments to LED technology is expected to speed up in the near future, opening up the question of how these products will be dealt with at the end of their usage. In particular, the unanswered question of appropriate and economic recycling processes for LED lamps and luminaires arises.

Besides the main materials like glass, plastics, metals, ceramics, organic potting compounds or adhesives and electronic components, the core part of LED lamps, the LED itself, contains small amounts of critical elements including rare earth metals (e.g. lutetium (Lu), cerium (Ce) or europium (Eu)), technology metals (gallium (Ga) and indium (In)) and precious metals (gold (Au) and

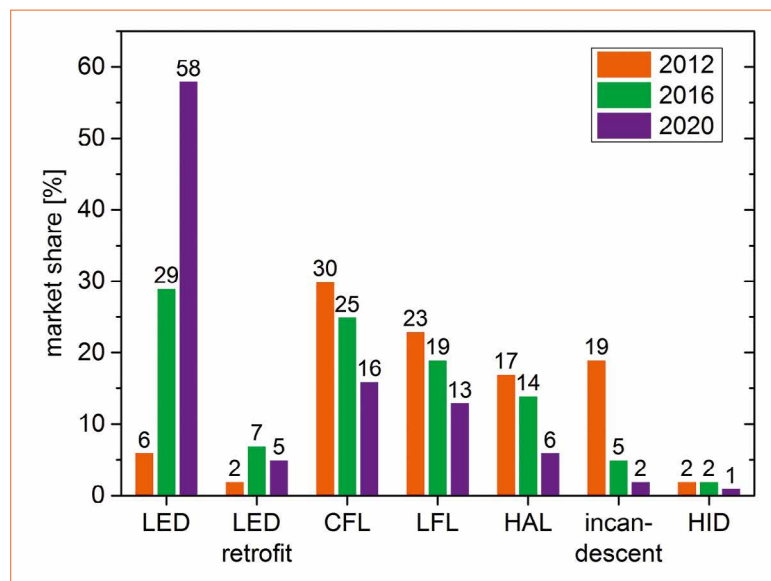

**Figure 1:**  
The multitude of waste lamps going to lamp recyclers: gas discharge lamps, retrofit LED lamps, and halogen lamps

silver (Ag). In spite of the still often used classical Edison-type lamp design, the inner lamp setup might exhibit many differences. To summarize: the variety of LED lamps on the market is manifold as is the number of lamps being taken to lamp recyclers (Figure 1).

### Status Quo of the Lighting Market and Future Trends

The consequences of the European Commission Regulations Number 244/2009 und 245/2009 are the phase-out of inefficient lamps like the incandescent bulb but also a drastic general change of the lighting market in Europe as well as worldwide. Figure 2 shows the global lighting market technology shares three years after these regulations came into force. Half of the revenues were due to gas discharge lamps; incandescent lamps had a share of one third, while LED-products represented only 8%. The forecast for 2016 and 2020 predicted a strong increase in the revenues of LED lamps at the expense of those from thermal emitters and fluorescent lamps. This estimate of market penetration by LED lamps was commonly agreed on [5, 12].



**Figure 2:**  
Predicted revenue distribution of the global lighting market as a function of light source technology [i] (illustration of McKinsey data [8])

Considering the current sales output in Germany, the forecasts are confirmed. According to a recent analysis by the German Energy Agency, dena, the sales output from LED-based lamps rose considerably within the last couple of years: While in 2009 only 1% of the sold lamps were based on LED technology, it was already 7% in April 2013 [3]. Nevertheless, it should not be forgotten that the general lighting market is still dominated by conventional, established technologies: This is, for example, the compact

fluorescent lamp in private households or the mercury vapor lamp for street lighting [ii]. Interestingly, these facts are no longer displayed in the current product portfolio of manufacturers and distributors where the LED clearly dominates.

The growing consumer acceptance for LED technology is triggered, amongst other things, by the declining prices, on one hand, and the remarkable technology evolution on the other. As compared to the days of their market introduction,

**Figure 3:**  
Mass fractions of the components of a typical state-of-the-art LED retrofit lamp (E27, 806 lm, 9.5 W, 85.5 g) from the recent range of products

especially the luminous efficacy and the LED light quality have been improved considerably. Additionally, LED lamps are free of toxic mercury and allow for a design freedom that cannot be realized by other established lighting technologies.

In order to get insights into the factors still limiting a substantial market penetration with solid state lighting products, the European Commission initiated a survey among stakeholders of the European lighting market in the year 2011 [4]. According to the results 14% of the informants responded that two aspects had not yet been considered properly.

**Figure 4:**  
A typical white LED: Photograph (left) and overlay of the main elements mapped by micro x-ray fluorescence spectroscopy (right)

Unconsidered aspects that might limit market penetration:

- Scarcity of the raw materials utilized in LEDs
- Recycling issues

Studies on behalf of the German Federal Environmental Agency [9, 10] come to the same conclusions. Despite the small amounts of critical materials used in LEDs it follows that proper collection strategies and appropriate methods to recover and recycle the valuable materials should be developed today.

### Valuable Materials in LED Retrofit Lamps and Expected Future Needs

LED lamps for private households have been available on the market since about 2007. Today, a customer can choose between various products with a different shape or socket type. The market not only offers 1-to-1 replacement lamps, so-called retrofits, but also luminaires with fixed LED-modules that cannot be exchanged. Due to this product variety it is not easy to quantify typical amounts of materials used in LED lighting equipment. However, it can be stated that the design of compact LED-based lighting products like retrofits usually requires the use of a cooling body to sustain proper temperature

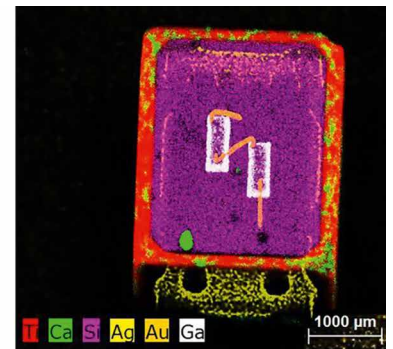
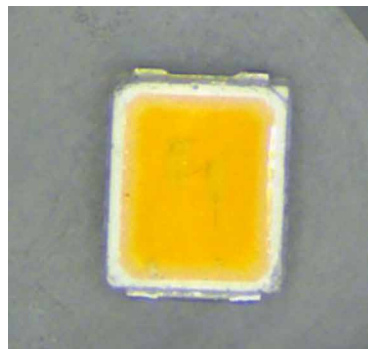
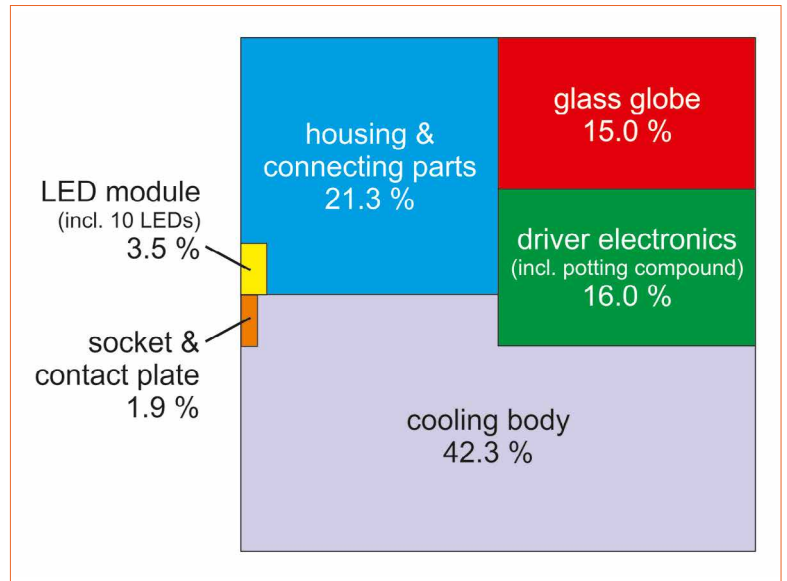

management. It is commonly made of aluminum or a thermally conductive ceramic and amounts to the larger part of the total retrofit mass.

Figure 3 illustrates the mass fractions obtained from the lamp analysis of a state-of-the-art LED retrofit lamp: The cooling body corresponding to 42.3% of the lamp mass is made of aluminum. The body and connecting components are plastic and amount to 21.3%. The driving electronics (16.0%) and the glass globe (15.0%) share about equal mass amounts. In this example, the LED-module comprised 10 SMD-LEDs that were mounted on an aluminum-based panel. The mass of all LEDs is only 275 mg or 0.32% of the total mass of the retrofit lamp.

The materials used in the driver electronics do not differ greatly when compared to those contained in a typical ballast for compact fluorescent lamps. Despite that, the material diversity is bigger in

retrofit lamps due to the LED devices themselves. In general, the functionality of white LEDs relies on the partial conversion of light from a blue-emitting diode by luminescent material, the so called phosphor [iii]. It consists of an inorganic matrix that is doped with small amounts of rare earth metals like Eu or Ce. A few  $\mu\text{g}$  are sufficient, e.g. 3  $\mu\text{g}$  Ce or Eu per 1  $\text{mm}^2$  LED chip [2], to enable the desired light conversion. Other rare earths metals might be core constituents of the inorganic matrix (ca. 90-200  $\mu\text{g}$  per 1  $\text{mm}^2$  chip size [2]). Examples are aluminate garnets like YAG (yttrium aluminum garnet), LuAG (lutetium aluminum garnet) or GdAG (gadolinium aluminum garnet). The blue LED is based on GaN or InGaN and typically contains 17-25  $\mu\text{g}$  of Ga and 28 ng of In [7]. The diode is often contacted via bond wires made of gold (Au), amounting to about 200 mg per diode [10]. Furthermore, the LED package also comprises silver (Ag), tin (Sn), nickel (Ni), titanium (Ti),

silicon (Si) or germanium (Ge) to name a few. The complex set-up of a representative white LED is shown in figure 4 as a micrograph and an overlay picture of the main element distributions mapped by micro x-ray fluorescence spectroscopy.

Bearing the above mentioned trends of the lighting market and the typical constituents of an LED retrofit lamp in mind, what amount of waste lamps is to be expected in Germany or Europe? The number of LED lamps to substitute lamps with classical technologies in households was estimated according to the approach by Spengler et al. [10] and yielded 277 million LED lamps per year for Germany and 1729 million for Europe [iv]. Taking the current market share of 7% into account and assuming 10 LEDs per lamp, there is a need of 193.7 million LEDs for Germany and 1.2 billion for Europe solely for the replacement of conventional lamps in households. Extending these considerations to other lighting segments (streets, industry, offices, retail etc.) the number of replacement lamps amounted to 3.29 billion in the EU in 2010 [10], thus translating to 2.3 billion LEDs under the conditions mentioned above. A proceeding market penetration by LED-products and possible rebound effects trigger even higher LED amounts that will be needed. A factor of 10 or more seems therefore realistic for the future.

Due to technological progress the lifetime of LED lamps is increasing, thus lowering the demand for re-placement lamps per year. Nevertheless, it should be kept in mind that the real lifetime of LED lamps depends significantly on good product quality as well as on proper use by the customer. Due to considerable price erosion product quality might suffer occasionally in a highly fragmented market like the lighting industry with many competitors and small companies. This applies, for example, to a sophisticated lamp design to sustain good heat transfer, sufficient thermal contact of the

LED module to the cooling body, and to the quality of the electrical components in the electronic driver.

Apart from their application in lamps, nowadays, LEDs dominate the display market. 60-80 million LEDs are used per year for display backlights [12]. Forecasts predict stagnation for this market segment until 2020, but anticipate a growth of the general lighting market leveling off at LED amounts of 130 billion per year [12].

Based on the discussed amounts of LEDs and their typical elemental compositions, the need for raw materials has been estimated for InGaN-based white diodes: 1 billion LEDs contain 17-25 kg of gallium and only 18 g of indium. Consequently, replacing 100% of all conventional household lamps in Germany (or in the EU) with LED lamps yields a raw material need [v] of 2.3-13.0 t (or 11.5-26.5 t) for gallium and 1.7-15.3 t (1.7-5.4 t) for indium [7, 10]. Comparing this demand with the annual global production of both metals in the year 2010 (106 t gallium und 574 t indium [10]) it becomes evident that 10% of the produced gallium is applied to LEDs. Growing markets, as they are predicted for general lighting, and an establishing LED technology in new products, will increase the demand as well as the consumption of raw materials. Geopolitical aspects might again play a role in the future: China is not only the biggest producer of various rare earth metals and rare earth metal compounds but supplies 70% of the global gallium production.

### What Lamp Recycling Is and What It Might Be

Waste lamps are liable to the WEEE directive and are listed in Category 5: Due to the employed mercury gas discharge lamps are hazardous waste and have to be collected separately (collection group 4). LED retrofit lamps have been classified recently as Category 5b. As they do not contain toxic compounds the producers pay only

about 10% of the waste disposal costs as compared to fees for mercury-containing gas discharge lamps. Nevertheless, LED retrofit lamps and fluorescent lamps are collected jointly, leaving the task of separation of both waste streams to the recycler. Other lighting equipment is collected with other small appliances in collection group 5. The joint collection of gas discharge and LED lamps is, on the one hand, useful. Due to the high similarity in appearance it might not be straightforward for the customer to decide prior to disposal, which technology is used in the respective lamp? This is particularly difficult for lamps with opaque glass or a plastic bulb. On the other hand, the joint collection bears the risk of cross contamination of all lamps with mercury if one or more gas discharge lamps break during the collection and/or transportation process. As a result, all lamps have to be treated as hazardous waste even though this is not necessary for LED products and disregarding the non-appropriate waste disposal costs. It follows that the separate collection of LED lamps should be aimed for.

Today, four established processes are used for lamp recycling to recover the major material fractions from the most common lamp types. As already stated, the lamp recycling business is focused on gas discharge lamps which are composed as illustrated in figure 5. The main material is glass whose recovery is actually the reason for the high recycling rate for lamps, exceeding 90% [6]. The recovery of metals and plastics also contributes

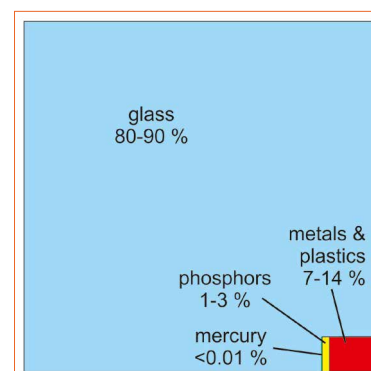

**Figure 5:** The composition of gas discharge lamps is about 40-170 g total mass (illustration of Lightcycle data [6])

to some extent. During the recycling processes the small material fractions containing critical (i.e. the phosphors containing rare earth metals) or toxic elements (mercury) are treated as impurities spoiling the main fractions. Consequently, measures are taken to clean the latter and to recover mercury. Even though a part of the waste phosphors is recycled using intricate wet-chemical methods, the majority is dumped in subsurface repositories.

The diversity of LED lamp designs is already high today but probably has not reached its climax yet due to the freedom of design offered by LED technology. In addition, the trend points to luminaires with integrated LED modules that cannot be exchanged by the customer any more. Referring to the rather high product lifetimes of several decades, this makes sense. However, it can be suspected that customers will increasingly get rid of still functional lamps or luminaires that are not longer in style, or to their liking, thus giving rise to new waste streams. This hypothesis is supported by our own investigations on waste retrofit LED lamps (provided by a lamp recycler) which revealed that many of them are, indeed, still functional.

Forward-looking recycling procedures for waste LED lamps should account for the variety of lamp geometries. This might be realized with sophisticated sorting facilities that can be integrated modularly into the process chain. In a future LED recycling system, the components containing critical elements (i.e. gallium, indium, rare earth metals like yttrium, lanthanum or europium and precious metals) - the LEDs themselves - can be regarded as impurities for the main material fractions. To keep the latter unsoiled the separation of the LED-packages from the rest should be aimed at in analogy to the separation of lamp phosphors from glass that is known from waste gas discharge lamp recycling. The positive side effect of this action is a concentration of the

components containing LED-specific critical elements for future recycling solutions. In any case, the rate of component, material and substance reuse and recycling will not be compromised by this measure and will presumably still exceed 90% [vi].

In general, the recycling rate depends on the available processes and their economic feasibility. The latter is also a question of geological and geopolitical availability of primary raw materials and current market prices. If reliable raw materials supply cannot be sustained any more, the link of recycling to market prices will be softened. The recovery of small material fraction will become a question of technological feasibility. Bearing these considerations in mind the concentration of critical materials in one single fraction and its storage are important steps in the development of recycling strategies for LEDs. Beyond doubt, the necessity for specific recycling procedures for LED lamps is currently not a pressing problem due to the long lamp lifetimes and the resulting low return rate of waste LED lamps (1% for Germany in 2016 [11]). However, the take-over and extension of the complete lighting market by LED technology clearly points to the perspective that the proper treatment of LED waste streams will become relevant soon. To develop appropriate recycling technologies for LED-based lighting equipment today and to do research on appropriate separation and

extraction procedures for the LED-specific valuable elements allows to be proactive rather than reactive. Furthermore, with regard to the low waste disposal costs that are paid for LED lighting equipment establishing a separate collection and recycling system for LED lamps and gas discharge lamps is considered advisable.

### An Approach Towards Economic LED Recycling

Figure 6 shows a schematic illustration of the process steps necessary to separate the material and component fractions found in typical retrofit LED lamps. The decisive step is a rather coarse fragmentation. Afterwards, the resulting material and component mix has to be sorted and classified using adapted procedures: Metal separators will be used, for example, to sort out metals that can be magnetized. Flotation methods are useful to segregate materials with strongly different density like plastics and ceramics. Sieving can be used to separate different grain sizes. The collected electronic components will be transferred to e-waste recyclers who will continue processing aiming at extracting copper from the electromagnetic coils. The LED packages are, in a first approach, treated as impurities for the main fractions (see above) and could be easily detected due to their intense fluorescence under UV-light irradiation. As long as there are no ready for use methods available to

**Figure 6:** Schematic illustration of a recycling process for LED lamps

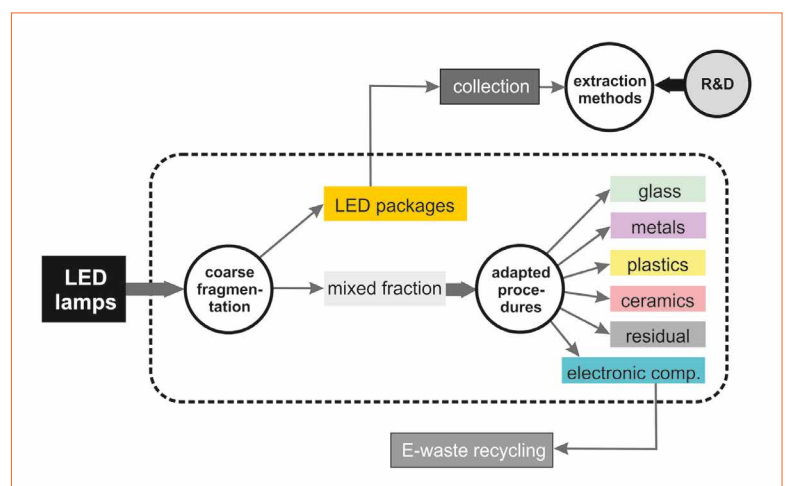

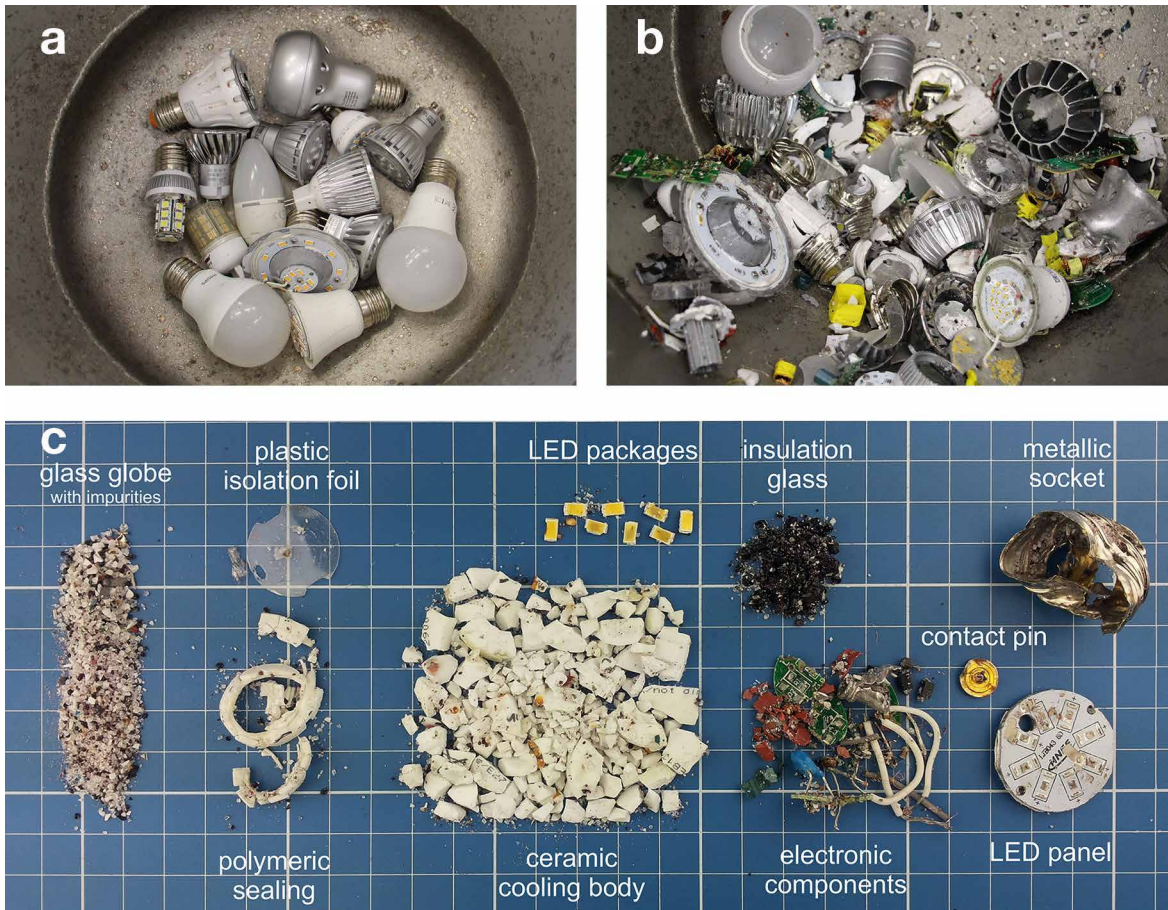

**Figures 7a-c:**  
 (a) Mix of waste LED lamps prior to EHF.  
 (b) Component and material mix obtained after EHF of the waste lamps shown in a. Here, a very coarse fragmentation was aimed at  
 (c) Fractions obtained after EHF of one single retrofit lamp and subsequent manual sorting

recover the critical elements from LEDs, they can be collected and stored using the common procedure for waste phosphors from fluorescent lamps. The required space to do so is very small thanks to the miniaturized device design.

Specific recycling strategies seem to be the best solution, in particular, smart separation technologies to dis-integrate the LED lamps into the constituting materials or components yielding fairly separated fractions after classifying and sorting as will be shown in the following. Using conventional processes like crushing, cutting or shredding the comminution is defined by the lump size. However, an intense comminution producing many small pieces is not the best solution for the disintegration of composite materials or products consisting of a complex material mix like lamps. Instead, the electrohydraulic fragmentation (EHF) method is used to selectively separate the materials, making use of the weakening of interfaces by shock waves. It is a method that proved to be very

effective for the fragmentation of electronic waste like hard disks or mobile phones, solar cells and also LED retrofit lamps. The shock waves are generated in a liquid medium (e.g. water) by pulsed high voltage (HV) discharges. They propagate through the medium until they hit the waste lamps placed inside the vessel (Figure 7 a). The short but intense mechanical impact preferably attacks weak spots like joints, defects and phase or grain boundaries. The fragmentation is thus initiated both on a macroscopic and microscopic level.

The electrohydraulic fragmentation might be conducted in several subsequent steps: Firstly, a release of single components can be achieved using only a few HV pulses. A presorting step can then separate the coarsely fragmented metal pieces, ceramic parts, circuit boards, LED modules or plastic parts that can be subsequently treated again with EHF to yield a finer fragmentation. One of the advantages of EHF is that the LED packages can be separated en

bloc and basically undestroyed by an appropriate choice of process parameters. This is very helpful when it comes to sorting.

Figure 7 illustrates an exemplary mix of different LED retrofit lamps before (a) and after (b) EHF treatment. After decantation and sorting of the materials and components the evaluation of the received fractions yielded a loss of only 0.5%. Consequently, 99.5% of all input mass could be comminuted and recovered.

In figure 7 c the fractions are shown that were obtained after the electrohydraulic fragmentation of one single retrofit lamp. Depending on the process parameters and the material level in the vessel, rather coarse or finer fractions are obtained. These can be sorted with common sorting techniques like sieving, metal separation or flotation methods

As waste gas discharge and LED lamps are collected jointly the risk of lamp contamination with mercury

cannot be excluded. For this reason, the process water has been analyzed after EHF with a mercury analyzer. No mercury contamination could be detected. Using inductively coupled plasma optical emission spectroscopy (ICP-OES) the process water has been analyzed further to trace possible metallic contaminations due to the lamp fractions, in particular the electronic components or the LED packages. It has been found that the water contained only small amounts (<70 mg/l) of different metals, mainly alkaline, earth alkaline and transition metals. The concentrations were nearly identical to the ones found in the blank test (fresh water) thus excluding dissolution of additional elements from the lamps in the process water. The result was in addition independent on the degree of comminution, i.e. the number of HV pulses used for the experiments. The process water has thus not been contaminated by the electrohydraulic fragmentation of waste retrofit LED lamps. It can be either reused or disposed safely after the suspended substances have been removed by filtration.

In summary, electrohydraulic fragmentation is an efficient, uncritical and environmentally friendly method to comminute waste retrofit LED lamps. One of its advantages is that the LED packages can be detached easily and predominantly undestroyed from the LED panel (Figure 7c). With this measure an important step has been taken towards the development of a successful

LED lamp recycling which also paves the way for the next step - the development of suitable extraction procedures for the valuable materials within the LEDs themselves - gallium, indium, gold and rare earths elements.

Before this issue can be tackled with regard to the rare earths used in LED phosphors, the latter have to be separated first from the binder material, usually a silicone resin. During the cycLED project [1] the so called CreaSolv® process was developed. Apart from the work on smart separation techniques for LED lamps the Project Group also does ongoing research on physical, chemical and biological methods to extract and recover rare earth metals, technology metals or precious metals from LEDs to solve this last relevant step.

### Conclusion

It is largely agreed on today that the LED will be the light source of the future. Since the invention of blue LEDs in the early 1990's and their use in phosphor-converted white LEDs, great progress has been made with respect to luminous efficacy and flux, color and color quality, lifetime and integration of features exceeding the illumination task. In spite of the very long lifetimes, considerably exceeding 10 years, all LED-based lighting equipment will sooner or later add to the electronic waste pile that is constantly growing in our society, especially as the amount of LED lighting products on the market is growing constantly.

The lamp recycling industry is currently geared to the treatment of gas discharge lamps focusing especially on the recovery of mass material fractions like glass, metals and plastics. The lamp phosphors containing rare earths are mainly landfilled belowground.

The development of adapted recycling technologies for LED lamps is, however, an important task to recover the main materials and to avoid the irrecoverable dissipation of the valuable elements within the LEDs (rare earths, semiconductors and precious metals). Ultimately, it might be an important step to secure Europe's independence from foreign raw materials supply.

Using the method of electrohydraulic fragmentation, the crucial first steps were done, i.e. the comminution of waste retrofit lamps of different geometry in an efficient, rather selective and environmentally friendly manner. The degree of comminution can be regulated by the process parameters. Sorting the generated material mix can be realized using commonly known technologies like sieving, magnetic separation or flotation. The liberation of basically undestroyed LED packages from the LED panel during EHF of LED lamps is an additional benefit paving the way for a future recovery of the valuable materials of the LEDs themselves - gallium, indium, gold and rare earths elements.

To solve this second step, intense research on chemical and biological methods is performed. ■

#### Notes:

- [i] LED light-emitting diode, CFL compact fluorescent lamp; LFL linear fluorescent lamp; HAL halogen lamp; HID high-intensity discharge lamps
- [ii] 60 % of European street lights are mercury vapor lamps. Since April 2015 their placing on the market is forbidden requiring a replacement of the respective lamps (about 21 million in EU) on a mid and long term scale
- [iii] For this reason white LEDs are often referred to as pc-LEDs or phosphor-converted LEDs.
- [iv] The assumption was based on the number of households in 2014 in EU (EU28), the candidate countries, and including Norway and Switzerland (250 million)
- [v] Note: Independent on the elemental composition of the LED the real need of raw materials for the device production is a factor of about 10 to 20 higher for gallium and even 1000-3000 times higher for Indium
- [vi] In accordance to European regulations the German Electrical and Electronic Equipment Act ("Elektrogesetz" / ElektroG) prescribes a recycling rate for waste lamps of at least 80 per cent by weight



### References

- [1] Details on the cycLED project are available online at <http://www.cyc-led.eu>
- [2] O. Deubzer, R. Jordan, M. Marwede, P. Chancerel, Categorization of LED products, Project report from the cycLED project, May 2012
- [3] German Energy Agency dena, Analyse der Energieeffizienz und Marktentwicklung von „Allgemeiner Beleuchtung“, December 2013
- [4] GREEN PAPER Lighting the future: Accelerating the development of innovative lighting technology, COM(2011) 889, 15.12.2011 & Results of the public consultation, 06.06.2012
- [5] Frost & Sullivan, World LED Lighting Markets, September 2012
- [6] <http://www.lightcycle.de/dossier-rueckholung-recycling-und-ressourcenschonung/led-und-energiesparlampen-reduzieren-den-muellberg.html> (last access 17.05.2016)
- [7] J. Thema, W. Irrek, Umwelt- und Ressourcenaspekte einer verstärkten Nutzung von Leuchtdioden, Report to work package 14.4 of the MaRes-Project, December 2010
- [8] McKinsey & Company Inc., Lighting the way: Perspectives on the global lighting market, Second edition, August 2012
- [9] K. Sander, S. Schilling, J. Wagner, M. Günther, Maßnahmen zur Optimierung der Entsorgung von quecksilberhaltigen Gasentladungslampen und anderen Lampenarten, Study on behalf of the German Federal Environmental Agency, September 2015
- [10] L. Spengler, A. Reihlen, K. Sander, D. Jepsen, N.; Reintjes, Expertise Leuchtdioden: Umwelt-, ge-sundheits- und verbraucherrelevante Aspekte von Leuchtmitteln auf Basis von LED, Study by the Ökopol Institute, 2013
- [11] Recent data from the German National Register for Waste Electric Equipment (“Stiftung Elektro-Altgeräte Register ear”), Feb. 2016
- [12] Yolé Développement, Status of the LED industry, Market analysis, 2013



# innovative Materials

along the upstream LED value chain

- LED Chip & Periphery
- LED Package
- MOCVD Precursor
- Sapphire Substrate

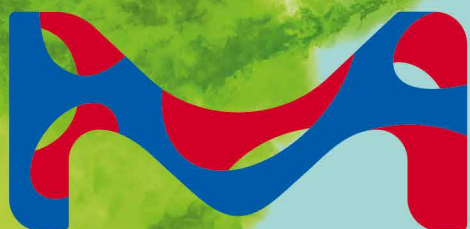

Visit us at LpS 2016 in Bregenz, Austria  
September 20 – 22, Booth #A6



## LED professional Review (LpR) - Annual Subscriptions

### LpR Digital Magazine

- 6 issues
- pdf download
- high resolution pictures and graphs
- printable
- commercial use
- access to all previous issues
- Euro 78.80

### LpR Printed Magazine

- 6 issues
- Euro 158.40

<http://www.led-professional.com/subscription>

### Cover-page

Artwork: Thomas Klobassa,  
©LED professional 2016

Main Image: Arno Grabher-Meyer,  
LED professional



TUV SUD demo lifetime test setup for MR16/GU10 lamps at LpS 2015

## Next LpR DESIGN & ENGINEERING Issue 57 - Sept/Oct 2016

### ENGINEERING

#### How to Design with LEDs - Concurrent Engineering Yields Fully Optimized Lighting Systems

LEDs are often viewed as a replacement for other light sources. The right starting point for designing an appropriate replacement is crucial to the result. The author describes a concurrent engineering approach that optimizes the optics and other system components, and may help to reduce the number of LEDs needed as well as the overall cost of the LED lighting fixture. ■

### RESEARCH

#### "Best Papers" at LpS 2015: Sky Luminance and Radiance Distribution Patterns - Empirical Assessment and Computational Models

Intelligent lighting control systems require an integrated treatment of daylight and artificial light. Sky dome luminance distribution pattern are critical, and predictive control approaches require that sky conditions are accurately captured. The research focuses on the evaluation of various sky models based on a large repository of high resolution measurements. The findings suggest that existing models must be substantially improved. ■

### TECHNOLOGIES

#### Lighting Fabrics – A New Approach for Flexible Light Sources

Lighting designers have been dreaming of truly flexible light sources for a long time. OLEDs are being promoted as the solution of the future but there are other solutions already on the market. The article takes a look at the common history of light and fabrics, the evolution of flexible circuitry and the latest development in form free scalable light sources. ■

### STANDARDIZATION

#### Metrics for Detection and Measurement of Optical Flicker and Stroboscopic Effect in LED Lighting

Optical flicker is a crucial and permanent topic in LED lighting. After briefly introducing optical flicker, the author describes how it impacts the quality of LED lighting and the lack of defined parameters to measure the presence of this phenomenon in lighting products. He explains why standards and standardized measurement are required, presents metrics for its detection, and finally proposes a test program and its parameters. ■

### ENVIRONMENT

#### Botanical Light Pollution

It is common knowledge that blue-rich light from high-CCT street lighting contributes to astronomical light pollution, but this is from a human perspective. From the perspective of wild and domesticated plants, it is red light in the range of 600 to 750 nm that is a concern. Plants rely on red and far-red light as environmental cues on when and how to grow. Therefore, lighting designers need to understand the issues of botanical light pollution. ■

subject to change

## Imprint

LED professional Review (LpR), ISSN 1993-890X

### Publishing Company

#### Luger Research e.U.

Institute for Innovation & Technology  
Moosmahdstrasse 30  
A 6850 Dornbirn, Austria / Europe  
phone +43 5572 39 44 89  
fax +43 5572 20 60 70  
info(at)lugerresearch.com  
www.lugerresearch.com

#### Publisher

Siegfried Luger +43 699 11 33 55 70  
s.luger(at)led-professional.com

#### Editor-in-Chief

Arno Grabher-Meyer +43 699 11 33 55 18  
a.g-m(at)led-professional.com

#### Int. Account Manager

Theresa Koenig +43 699 11 33 55 20  
theresa.koenig(at)led-professional.com

#### Marketing & Sales Manager

Theresa-Anna Luger +43 699 11 33 55 19  
theresa.luger(at)led-professional.com

### Your Local Contacts

#### China, Hong-Kong

Iris Yuen +86 1380 27 01 367  
irisyuen88(at)gmail.com

#### Germany

Armin Wezel +49 30 526 891 92  
armin(at)eurokom-media.de

#### Japan

Eiji Yoshikawa +81 3 6751 0090  
scala(at)s3.dion.ne.jp

#### South Korea

Jung Won Suh +82 2 78 58 222  
sinsegi-2(at)sinsegi-media.info

#### Switzerland

Monika B. Ailingner +41 41 850 44 24  
m.ailingner(at)marcomedia.ch

#### Taiwan

Leon Chen +886 2 256 81 786-10  
leon(at)jkmmedia.com.tw

#### United Kingdom, France & Benelux

Zena Coupé +44 1923 85 25 37  
zena(at)expomedia.biz

#### US East

Karen C Smith-Kernc +1 717 397 7100  
KarenKCS(at)aol.com

#### US West & Canada

Alan A. Kernc +1 717 397 7100  
AlanKCS(at)aol.com

### Copyrights - Luger Research e.U.

The editors make every reasonable effort to verify the information published, but Luger Research e.U. assumes no responsibility for the validity of any manufacturers, non profit organisations or individuals claims or statements.

Luger Research e.U. does not assume and hereby disclaims any liability to any person for any loss or damage caused by errors or omissions in the material contained herein, regardless of whether such errors result from negligence, accident or any other cause whatsoever. You may not copy, reproduce, republish, download, post, broadcast, transmit, make available to the public, or otherwise use LED professional Review (LpR) content without prior written consent from Luger Research e.U. - Institute for Innovation & Technology, Austria. ■

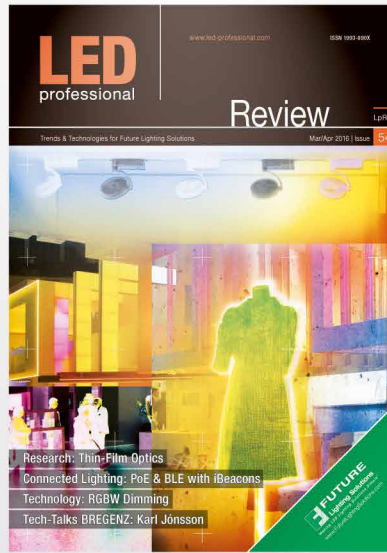

**!** GET YOUR FREE E-MAGAZINE  
[www.led-professional.com/free](http://www.led-professional.com/free)



# Trends & Technologies for Future Lighting Solutions.

LEDs • OLEDs • Light Engines • Lighting Modules • Optics • Drivers • Thermal Management • Lamps • Fixtures • Production & Measurement Equipment  
Project Reports • Patent Reports • Research Reports • Event Reports

**LED**  
professional

MORE THAN  
**25,500**  
READERS

[www.led-professional.com](http://www.led-professional.com)

powered by Luger Research e.U.

Submit your article. Please contact Arno Grabher-Meyer, Editor in Chief, at [a.g-m@led-professional.com](mailto:a.g-m@led-professional.com)

# ACEVEL



UGR < 19  
CRI 80  
115lm/W

CRI 80  
120lm/W

CRI 90  
105lm/W

ACEVEL GROUP | [www.acevel.com](http://www.acevel.com) | [info@acevel.com](mailto:info@acevel.com)

