

Interview: Julia Frohleiks

Research: Freeform Optics Optimization

Technologies: Multi-Pixel LED Technology

Engineering: Thermal Management

FUTURE
Lighting Solutions
www.FutureLightingSolutions.com
light+building
18.-23.3.2018 Frankfurt am Main
Visit us at our stand!
We look forward to seeing you.
Hall 4.1, Stand G10

NEW CREE® XLAMP® LEDs CAN:

IMPROVE RELIABILITY ::

REDUCE SYSTEM COST ::

REDEFINE LED LIGHTING ::

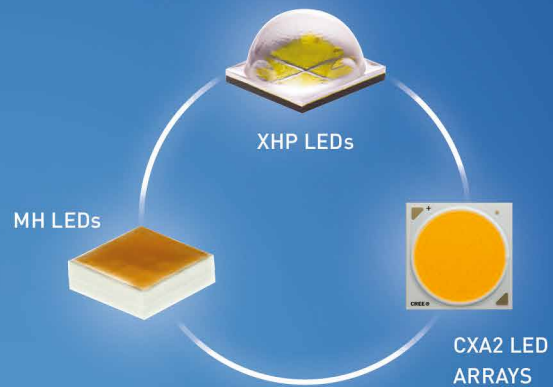

GAME CHANGING IS GREAT. BOTTOM LINE CHANGING IS BETTER.

You can't change your bottom line by using the same LEDs that everyone else is using. Cree's Extreme High Power (XHP) LEDs deliver double the lumen output at high operating temperatures, while our MH LEDs combine the system advantages of our best arrays with the manufacturing ease of a discrete. And our CXA2 LED arrays are packed with lumens to offer system cost savings up to 60%.

CREE 

See how higher power equals lower cost.
cree.com/xhp

The new way to a better LED array.
cree.com/mh

Even more lumens for savings up to 60%.
cree.com/cxa2



TAIWAN INT'L LIGHTING SHOW

Smart DESIGN
Radiant LIFE



2018
APR. 25 - 28

Taipei World Trade Center (TWTC) Exhibition Hall 1

FEATURING:

- Lighting Integration
- Lighting Design
- Home/Residential Lighting
- Commercial Lighting
- Intelligent Lighting
- Outdoor Lighting
- Lighting for Kitchen & Furniture
- Plant Factory & Lighting
- Automotive Lighting
- Special Lighting
- Health Care and Institutional Lighting
- Medical, Cosmetic and Beauty Lighting
- Building Material & Lighting Applications
- Neon/Light Boxes
- Lighting Accessory
- Lighting Production Equipment
- Test & Inspection Equipment

www.TILS.com.tw



Sponsored by :



Bureau of Foreign Trade, MOEA

www.trade.gov.tw

Organized by :



Taiwan External Trade
Development Council (TAITRA)

www.taipeitradeshows.com.tw



Taiwan Lighting Fixture
Export Association (TLFEA)

www.lighting.org.tw

Supported by :



SEMI TAIWAN

www.semi.org

AD by BOFT



Smart World

Technical systems tend to evolve in the direction of self-controlling. “Self-Systems” can be found in many fields of applications; just think of self-controlled cars, vacuum cleaners or lawn mowers. In so-called “dark-factories” leading smart-phone manufacturers are producing devices without any support from human beings and without the need of light, (therefore the name: dark factory).

Self-systems inherently require controlled loops and a huge amount of sensing opportunities to reach the self-status. Sensing, controlling and the ability to adapt their behavior are important functionalities of self-systems. We could also say that artificial intelligence learning algorithms are part of sophisticated self-systems.

In our smart and connected world, systems are linked up to the cloud because on and through a higher system level it's possible to combine information, optimize algorithms and update systems, if necessary. Internet connectivity is therefore a key aspect of new developments.

The smart devices within the smart world offer an enormous potential of new opportunities. Just think about the success stories of nearly all, modern connected consumer smart devices, such as tablets, phones, and home-systems.

Digitization and connectivity are revolutionizing the lighting domain in the same manner as other industries and applications. It will be a challenge during the coming years to keep up with these trends, which show extremely short development cycles.

On the other hand, any new development does show side effects. In this sense, new systems show problems such as security issues, complexity issues and maintenance concerns. The big challenge for the lighting industry is to be part of these latest developments, on the one hand, and to ensure the easy and secure usage of lighting, on the other hand.

The primary function of lighting systems is still and will always be the capability to deliver the right light for a specific usage in a certain application. Optimized light, or let's say, Human Centric Lighting, has to stay and will stay the original, primary goal of any lighting system. LEDification, with spectra-optimized solutions, made huge improvements in a broad range of applications. The add-ons of digitalization and connectivity can complete the developments of lighting systems in and for the smart world we are living in.

I wish you a great start to 2018 and a good read of issue 65 of the LpR.

Yours Sincerely,

Siegfried Luger
Publisher, LED professional

Almost too beautiful just
for the road – lighting
design with PLEXIGLAS®.

What does a leading specialty chemicals group have to do with car design? For over 60 years, Evonik, with its PLEXIGLAS® molding compounds, has been a driving force behind the auto industry. Why? Because the multifaceted ways in which PLEXIGLAS® can be formed open up virtually endless possibilities for design. One shining example is crystal-clear or colored PLEXIGLAS® whose top light-guiding properties and color stability make for innovative automotive lighting systems. For more inspirational PLEXIGLAS® products, go to www.plexiglas-polymers.com.

PLEXIGLAS® 



 **EVONIK**
POWER TO CREATE

COMMENTARY

- 08 Can You Show Me the Next S-Curve, Please?
by Dr. Guenther Sejkora, LED professional

TECH-TALKS BREGENZ

- 34 Julia Frohleiks, Researcher, University of Duisburg-Essen
compiled by Dr. Guenther Sejkora, LED professional

RESEARCH

- 38 Optimization of Freeform Optics Using T-Splines in LED Illumination Design
by Annie Shalom Isaac et al., Karlsruhe Institute of Technology
- 44 Repro-Light - Looking for a Sustainable and Modular Luminaire Architecture
compiled by Arno Grabher-Meyer, LED professional

TECHNOLOGIES

- 48 Multi-Pixel LED Technology Opens New Horizons for Smart Lighting Applications
by R. Bertram & N. Harendt, Osram Opto Semiconductors

ENGINEERING

- 54 Thermal Simulation Tool for LED Design Requirements
by Chris Aldham, 6SigmaET

AUTOMOTIVE

- 58 Flicker-Free Control of Individual LEDs in Matrix Headlights
by Keith Szolusha, Linear Technology/Analog Devices

REGULARS

- 04 EDITORIAL
- 08 COMMENTARY
- 10 PRODUCT NEWS
- 24 RESEARCH NEWS
- 26 EVENT NEWS
- 30 CIE RESEARCH

- 66 ABOUT | IMPRINT

HIGHLIGHT

- 40 Multi-Pixel LED Technology Opens New Horizons for Smart Lighting Applications
by R. Bertram & N. Harendt, Osram Opto Semiconductors



ADVERTISING INDEX

FUTURE LIGHTING SOLUTIONS	1	GRE ALPHA ELECTRONICS	16	FUTURE LIGHTING SOLUTIONS	47
CREE	2	EPISTAR	17	GUANGZHOU INT. LIGHTING EXHIBITION	53
TAIWAN INT. LIGHTING SHOW	3	INTERLUMI PANAMA	23	EDISON	63
EVONIK	5	TIL	27	LED EXPO THAILAND	65
LEDFRIEND	7	LPS	29	LPR	67
INSTRUMENT SYSTEMS	9	CREE	42	WAGO	68
MOSO	12	FULHAM	43		

Our SMART control is MUCH MORE than wireless dimming.

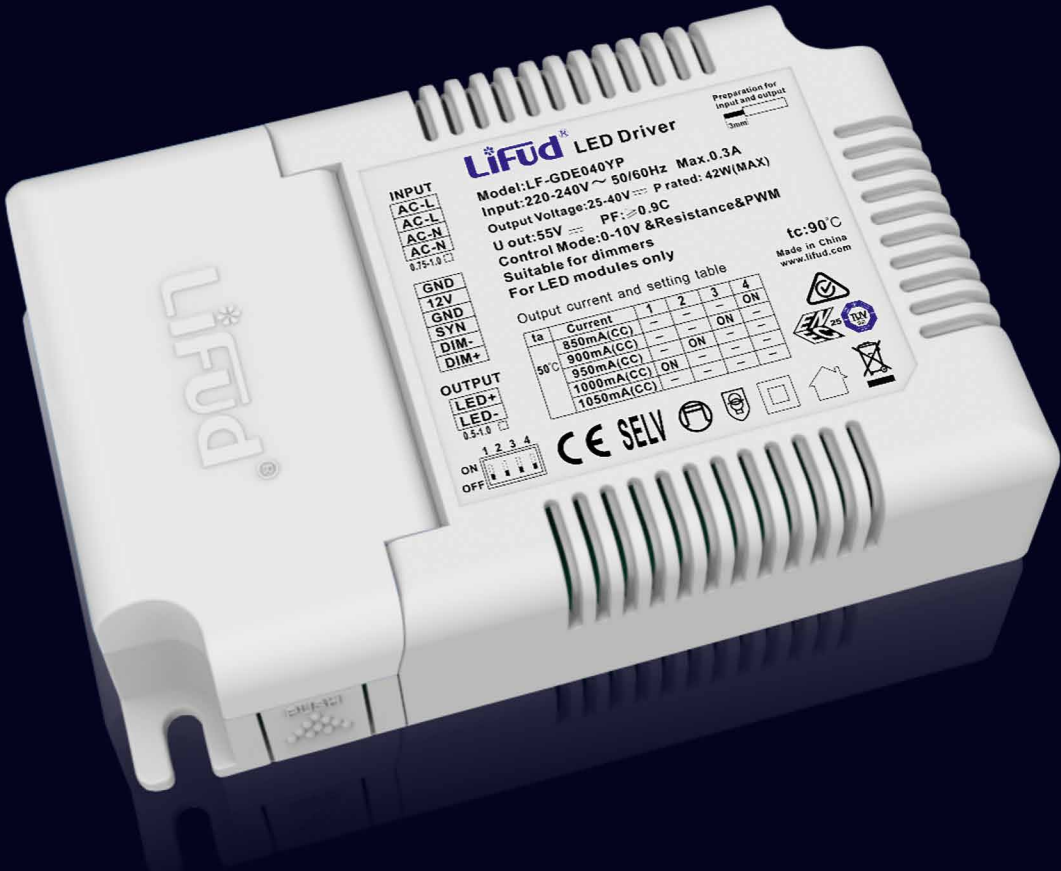

LIFUD®
www.lifud.com

FRANKFURT LIGHT + BUILDING FAIR
 BOOTH: H10. 1, E65 | DATE: 18 TO 23 MAR. 2018



Günther Sejkora

Günther Sejkora received his PhD from the University of Innsbruck after studying physics, IT and mathematics. He spent more than 20 years in the Research & Development department at Zumtobel Lighting and then went on to start his own company, “items” where, together with industrial partners, he has carried out more than 50 R&D and technology projects in the fields of LED lighting and lighting controls. He was Managing Director of the Kompetenzzentrum Licht GmbH from 2010 to 2015 and is currently the Research and Innovation Manager at Luger Research.

CAN YOU SHOW ME THE NEXT S-CURVE, PLEASE?

The evolution of technologies is often described using the “S-curve” model. In the early stage, in the first phase of its life cycle, technology is mainly driven by fundamental research. Only a few players are active at that time and innovation steps are quite large. In the second phase, early adopters start to develop products and bring them to market. This phase is characterized by huge investments. In the third phase, more and more players enter the technology field, competition becomes important and development speed of the technology decreases. In the last phase, the technology is mature, (nearly) everybody can use it, there are fewer margins and the technology should be replaced by a new one. Many of the SSL technologies have meanwhile reached maturity. Where are the upcoming technologies, what will be the next S-curve? Looking at technology discussions and lectures at LpS 2017 I tried to find answers to these questions.

In his keynote speech, Jan Denneman (Global Lighting Association) identified IoT/connected lighting and Human Centric Lighting (HCL) as the next technology S-curves. An analysis of the LpS 2017 lectures shows that connected lighting is based on mature communication technologies that are already in a late stage of their life-cycle. Of course some aspects have to be adopted for lighting; for example, low latency for IoT devices with limited computational resources are mandatory for lighting devices as explained in one of the lectures. But these adoptions will be small innovation steps. Devices ready for the lighting market have been presented and will be available for everyone. Differentiation potential and chances for growth in the lighting industry will be very limited - even if adoption of the technology is a must for everyone in the branch.

HCL is different. Several lectures dealing with fundamental research on

the effect of light on humans were presented but little implementation of research results into products or systems was shown. This brings me to the conclusion that we are still in a very early stage of the HCL S-curve (for the past 10 years). How the development of this technology will look and how fast it will start to rise is hard to estimate. But human centric lighting has the potential to become one of the next S-curves in solid state lighting.

There are other technologies that can be compared to IoT and HCL that might become one of the interesting S-curves. Quantum dots (QD) are still an object of basic research, as the work of Ekaterina Nannen, winner of the LpS 2017 Scientific Award, shows. But there are also promising steps towards market introduction of LEDs with QDs. Naturally, work still has to be done to develop cadmium free QDs but this technology could be an energy efficient replacement for phosphors, providing high level light quality. They can also be used as light emitters, as Ekaterina Nannen showed.

Laser diode (LD) systems show very promising properties, at least for narrow beam systems or systems with special light distributions. Although automotive head lamps have already been realized using this technology, the conference showed that there is still some ongoing research. Especially phosphors and conversion systems have to be optimized and characterized. No new applications of LD systems in products were shown, which may be taken as evidence that LD lighting is in an early stage of the S-curve.

We can never predict how a technology will develop; when the S-curve will start to rise or how important the technology will become. To ascertain which technologies might be of interest in the future, an analysis of the conference topics would help. ■

G.S.

Starring CAS 140D!



See us at
SIL USA
Booth 501

This spectroradiometer sets the standard for LED/SSL and display:

- ▲ Superior measuring sensitivity, precision, dynamic range and minimized straylight
- ▲ Constant repeatability in changing ambient temperatures
- ▲ Faster electronics with higher resolution
- ▲ “Plug & Play” accessory identification
- ▲ Proven lab and production software: SpecWin Pro/Light, DLL and LabView
- ▲ Also available for UV or NIR applications

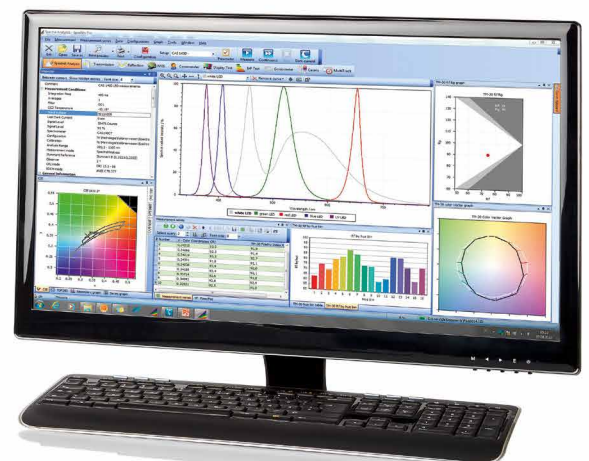

We bring quality to light.

New Osram LED for Headlights on all Vehicle Classes

Osram Compact PL combines new chip technology with excellent thermal properties. Osram Opto Semiconductors has added the new Osram Compact PL to its portfolio of products for the automotive sector. The LED is particularly suitable for use in vehicle headlights. It can be used for adaptive glare-free high beam, daytime running lights, low beam and standard high beam. This all-rounder combines improved design with low system costs, making it suitable for different vehicle classes and accessible to a broad spectrum of customers.



Osram Opto's ceramic-based Osram Compact PL can be operated at high currents and achieve high light output thanks to the new thermal pad

The ceramic-based LED is particularly impressive for its thermal behavior thanks to an electrically insulated thermal pad. In combination with appropriate PCB technology, the Osram Compact PL can be operated at high currents and achieve high light output.

In addition to the Osram Compact CL, which is available as a single-chip version, the portfolio now includes the Osram Compact PL as a multichip version with up to five chips. Equipped with notchless UX:3 chip technology, the new LEDs from Osram Opto Semiconductors offer excellent thermal conductivity. This is thanks to the square emission surface of the notchless chips, which also makes contacting and the optical design much simpler. The high luminous flux of the Osram Compact PL also provides improved brightness values. For applications that previously used halogen a luminous flux of 1,000 lm can be achieved with one Osram Compact PL 3 chip, for example.

“With the Osram Compact PL we are adding powerful ceramic-based LED types to our

portfolio. Our bandwidth of products with different package technologies for exterior lighting on cars is now even more extensive, with each offering its own benefits depending on the particular application. This means that we can deal much better with the individual wishes of our customers”, explained Thomas Christl, Marketing Manager Automotive Exterior at Osram Opto Semiconductors.

The new ceramic package with its particularly robust material properties improves handling and reliability. Osram's own binning method is being used in the development of the LED, which makes further increases in brightness available to customers in short intervals of time. The design of the components can therefore be optimized and adapted to cater for higher minimum brightness values or specific thresholds. ■

Cree Launches Industry's First Extreme Density LED

Cree announces the commercial availability of the XLamp® XD16 LED, the industry's first Extreme Density LED, which delivers up to 5½ times higher lumen density than Cree's previous generation of high power LEDs. Built on Cree's groundbreaking NX Technology Platform, the XD16 LED combines breakthrough lumen density, low optical cross-talk, unsurpassed thermal contact and ease of system manufacturing to enable innovative new designs for a broad spectrum of lighting applications, such as color-tuning, street, portable and industrial.

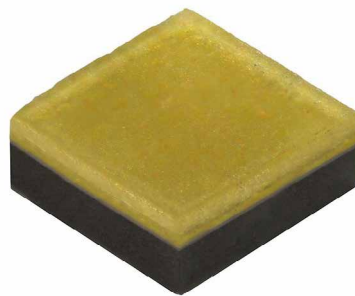

Cree's XLamp XD16 LED is first to surpass the 280 lm/mm² lumen density mark

“Cree's new XD16 LED delivers an incredible amount of light output for such a tiny package,” said Joe Skrivan, senior technical director at Black Diamond Equipment.

“The XD16 LED's breakthrough lumen output and peak intensity is a game-changer for our climbing headlamp products because we can design better beam control and decrease the overall size and weight compared to existing designs.”

The XLamp XD16 LED delivers a lumen density of more than 284 lumens per square-millimeter, which is the highest level achieved by a commercially available lighting-class LED. The ceramic-based XD16 LED utilizes the proven XQ footprint and successfully addresses challenges with luminaire manufacturing, thermal design, optical design and reliability faced by competing LEDs. For example, the XD16 LED reduces system-level optical loss by up to three times versus competing technologies when LEDs are placed close together on a board. This improvement translates into fewer wasted lumens and higher efficacy for lighting products.

“Cree's new Extreme Density LED demonstrates that true LED innovation improves our customers' system performance without forcing compromise,” said Dave Emerson, Cree LEDs executive vice president and general manager. “The XD16 LED delivers unmatched lumen density without the design and manufacturing challenges associated with inferior LED technology approaches. Now, lighting manufacturers can easily achieve previously unattainable levels of light output and efficacy in their existing form factors.”

The new LEDs are characterized and binned at 85°C, available in ANSI White, EasyWhite® 3- and 5-step color temperatures (2700–6500 K), and CRI options of 70, 80 and 90. ■

LG Innotek Unveils the World's First 100 mW UV-C LED

LG Innotek announced that the company has developed the world's first 100 mW UV-C LED. This development is 2 years ahead of the industry forecast that predicted its development would be successful by 2020.

UV-C LED is a product that emits ultraviolet light with short wavelengths ranging between 200 - 280 nanometers (nm), and is also called Deep UV. It is used in sterilizing and

hardening devices with its ability to destroy bacterial DNA and cause chemical reactions with special materials. LG Innotek's product emits UV in the range of 278 nm.

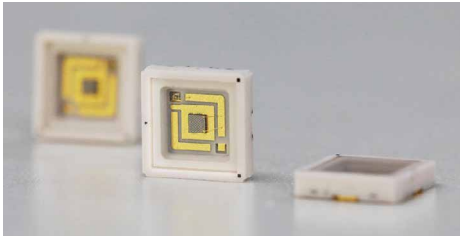

LG Innotek's new UV-C LEDs are a huge step forward toward new applications due to the massively increased radiated power of 100 mW

UV-C LED can produce more powerful sterilizing effects with higher light output, but it is very difficult to obtain a stable quality in products with it due to heat. The companies that have led the market have also planned to launch the 100 mW UV-C LED by 2020.

LG Innotek has overcome the technological limit by applying the epitaxial structure and the vertical chip technology that maximize light extraction. The ultraviolet output is raised and the heat is discharged effectively, ensuring stable quality reliability. This one 100 mW UV-C LED can emit strong sterilization ultraviolet light for more than 10,000 hours.

With this development of the product having a light output of 100 mW, LG Innotek has now become capable of expanding its UV-C LED application field. As the product can rapidly sterilize flowing water and even air, it can be used in a wide array of household appliances from water purifiers and air purifiers to air conditioning systems for buildings and automobiles as well as water treatment devices.

Conventional UV-C LEDs with a light output level of 1-2 mW are mostly used for portable sterilizers or small household appliances. Due to their low UV-C power, their scope of application is limited.

As the company has discussed development of a variety of products using UV-C LED with a number of other global companies and the demand for high-output LEDs continues to grow, it is expected that the demand for 100 mW UV-C LEDs will also increase rapidly.

LG Innotek intends to accelerate its securing of the UV LED market leadership.

In particular, the company has confidence in hitting the market with its unrivaled technology in the UV-C field that can offer excellent sterilization and curing performance.

The company's quality competitiveness has been proven by its launching of innovative products such as the LED module for sterilizing water purifier faucet aerator and the UV LED sterilizer for escalator handrails one step ahead of its rivaling Japanese companies.

According to the market researcher, the UV LED market is expected to more than triple to \$526 million by 2020 from \$166 million of last year. In particular, the portion of UV-C in the market will increase from \$28 million to \$244 million during the same period, leading the company's growth.

A representative of LG Innotek said, "We will continue to widen the technological gap with our competitors and introduce innovative products that our customers desire to stay the leader of the market." ■

Lumileds' Color Portfolio Gets Double-Digit Performance Upgrades

Lumileds announced that it has considerably improved the flux across its color LED family. Performance improvements to the flagship Luxeon C Color Line includes 20% higher lumen output in its Luxeon C Green and Cyan compared to the previous generation; the Luxeon C Red-Orange features a 12% flux increase.

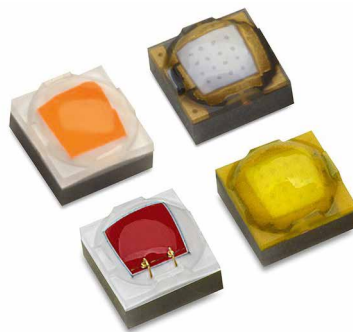

The Luxeon Color LED family completed a flux upgrade to a variety of its color offerings, including significant flux improvements to Green, Cyan, Red-Orange and Red LEDs

"As the demands on our customer's fixtures become more challenging, we need to ensure our Color portfolio enables them to

meet these demands. This increase in flux across several key colors will give our customers a significant boost in performance in existing designs as well as allow them to start from a higher level of performance in new designs," said Jennifer Holland, Product Line Director of the Luxeon C Color Line.

Specifically engineered for color mixing through its standard focal length, the Luxeon C Color Line is ideally suited for use in architectural, stage lighting, emergency vehicle lighting, and color tunable lamps and fixtures. All Luxeon C Color Line LEDs are hot tested at 85°C to ensure excellent performance at application conditions. Its thermal resistance, the lowest in the industry at 2.8°C/W, also helps reduce heat sink cost—or allows LEDs to be driven harder for higher output than is achieved with a competitor's LEDs.

Extending these performance upgrades to other lines within the Luxeon Color LED family, Lumileds is also excited to announce 20% flux improvements for the Green and Cyan colors on Luxeon Z Color Line and Luxeon Rebel Color Line.

Samsung Introduces Chip-on-Board LED Packages Optimized for Commercial Lighting

Samsung Electronics Co., Ltd., a world leader in advanced digital component solutions, announced a new family of chip-on-board LED lighting packages, labeled the "Samsung D-series Special Color." The packages are engineered to bring out the most desirable color tones of objects whose viewing is particularly color-sensitive, making them optimal for many commercial lighting applications.

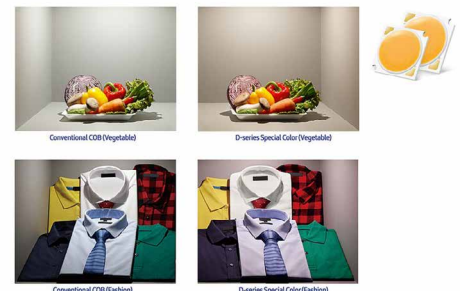

Two examples for "Samsung D-series Special Color" CoB package applications bringing out the most desirable color tones of illuminated objects

Through spectrum engineering, color spectrums within the D-series have been tuned to deliver exceptionally high color vividness without the use of harmful ultraviolet (UV) lighting chips. The packages deliver a TM-30* Gamut Index (Rg) of over 110, a level that ensures lighting with outstanding color and whiteness. Today, to provide almost as vivid color, many LED lamps instead use “near-UV” chips, which can damage the human eye and clothing after repeated exposure. Near-UV rays can display vivid colors, but only when the whites in the object being illuminated contain fluorescent brightening agents. An alternative is to use expensive ceramic discharge metal-halide (CDM) lamps that do not last nearly as long.

As color has a significant influence on consumer purchase decisions, the new D-series now offers lighting options for three of the most important segments of commercial goods: fashion (stylish clothing), meat and vegetables. The LED packages for each segment have been designed with the most effective combination of phosphors to illuminate what is being sold in the most appealing way. To determine the most attractive color rendering and saturation levels based on subjective perceptions, Samsung ran extensive preference tests among many demographic groups worldwide.

“Our new ‘D-series Special Color’ brings much greater value to the commercial lighting industry, reaching far beyond the ordinary image-rendering benefits of LEDs,” said Jacob Tarn, executive vice president of the LED Business Team at Samsung Electronics. “We are determined to continue to be the leading innovator in LED component solutions that are not only outstanding in quality, but which also bring the most practical benefits to the ultimate user – consumers.”

The “D-series Special Color” has been in mass production since late last month. Packages generate from 13 to 33 watts to create the best combination of LEDs and phosphors for each commercial segment. Furthermore, they come in the same shapes and sizes as the standard Samsung D-series to simplify retrofitting of existing luminaires.

LG Display’s Gen 5 OLED Production Started in New Facility

LG Display announced that the company started mass production at its new Gen 5 OLED light panel production line in Gumi, Korea and launched its new OLED light brand, Luflex. With these moves, the company will lead the lighting market, providing a powerful boost to the nascent sector globally.

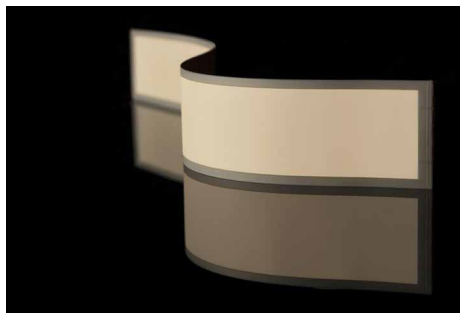

LG Display’s latest OLED generation is produced on the new Gen 5 line that handles 1,100x1,250 mm substrates

The Gen 5 line (1,100x1,250 mm) initially produces 15,000 sheets per month, which is about a 30-fold increase as compared to the previous Gen 2 line (370x470 mm) with monthly capacity of 4,000 sheets. The production capacity will be gradually ramped up.

“LG Display’s step to start mass production at the new line marks a significant turning point in the lighting industry,” said Sung Soo Park, Vice President and Head of the OLED Light Business Division at LG Display.

“We expect that this will improve the price-competitiveness of OLED light technology which in turn will trigger widespread adoption of OLED lighting around the world.”

LG Display also unveiled its new Luflex brand for the company’s OLED light panels. Luflex is a portmanteau of “lux” (light in Latin) and “flexibility,” reflecting a core characteristic of OLED lighting – that it is flexible, bendable and rollable, making it highly design-friendly. It is also a value creator that offers a premium sense by converging naturally into various applications, such as mirrors and furniture.

“The launch of the new brand along with the expanded production at the new line reflects our belief that OLED lighting has unlimited potential and it demonstrates our commitment to lead the market,” said Park. “We are confident that Luflex will become a representative brand in the OLED lighting industry.”

OLED light panels offer high commercial potential for lighting manufacturers. As a lighting solution, OLED is easier on the eyes than conventional sources such as fluorescent and LED, as it is very close to sunlight and offers great uniformity in its luminescence. It is virtually heatless, meaning that it can be used to illuminate, for example, food displays or antique wooden furniture or buildings.

At just 0.41 mm thick, OLED light panels are super slim and their flexibility means that they can be creatively shaped into curves or spirals – an attribute impossible before, and which cannot be done with other light sources. OLED lighting panels have already been adopted for experimental applications by world-famous industrial designers including Ron Arad and Ross Lovegrove. Customers have commented that OLED lighting installations, beyond providing simple illumination, can actually improve the attractiveness of spaces.



MOSO Launched a New Cost-Competitive EHC Family with Input Protection and Low THD

To protect the luminaires from challenging power conditions, the constant current EHC series drivers will cut off the output automatically when the input voltage is higher than the rated operating voltage and still survive after 48 hours 440 V ultra high input. With more compact size, lower THD, EHC series maintains the features of IP67 waterproof, fully glue-potted and metal case as all MOSO outdoor drivers and offers a much more cost-competitive option for the basic requirements of all customers.

For further product information, please sen an email to yoyo@mosopower.com

MOSO®

LG Display has started mass production of OLED tail lights for automobiles, which has drawn attention from global automakers and tier-1 component companies. In the case of general OLED lights, the company has established various installations in hotels, retail spaces, food and beverage outlets, universities, etc., and more and more customers are making inquiries after seeing these projects. The overall market environment is turning more and more positive and encouraging towards OLED lights.

Adura LED Solutions Announces Color Tunable LED Modules

Adura LED Solutions announced a new line-up of High Power LED on Board (LoB) modules for indoor and outdoor lighting that features color tunability and increased design compatibility. The new module 2024C LoB can be driven from 50-250 W using a variety of 3535 packed LEDs from Cree, Nichia, Lumileds, Seoul Semiconductors, Samsung and other LED suppliers.

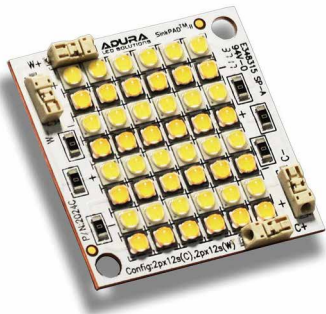

The new LoB module (2024C) is available in 38x38 mm form factor

“Our new 2024C LoB modules provide an optimal thermal solution for lighting manufacturers by using our patented SinkPAD™ II PCB Technology and Copper substrate (400 W/mK thermal conductivity). The new color tuning module 2024C offers a wide range of lighting benefits and flexibility such as significantly reducing heat from the LED (SinkPAD™ II PCB Technology), the small size and high light density to enable more compact fixture designs”, said Abdul Aslami of Adura LED Solutions.

The demand for tunable white light is increasing because customers are now well aware of the benefits of having a tunable white light that match the progression of

natural daylight from cool day light in the morning to warm light at night for residential, commercial, retail, hospitality, studio, stage, museum and industrial application.

The new LoB module (2024C) is available in form factor (38x38 mm), and compatible with third party company LoB module holders, lenses and provides high-quality lighting in diverse beam angle options.

Fulham Introduces Universal Voltage DirectAC LED Engine and Retrofit Kit Versions

Fulham, a leading supplier of lighting sub-systems and electronics for commercial and specialty applications, announced the release of universal voltage versions of its DirectAC direct-drive LED units. The DirectAC LED Engines were released earlier this year in a 120 V and with this product release, the same low-profile, self-contained LED engine with integrated driver is now available in a new unit that can support power ratings from 120 to 277 volts.



Fulham's new universal voltage direct AC LED modules feature integrated drivers and are suitable for open and closed luminaires with or without lenses

The DirectAC LED Engine was designed with the driver integrated on the circuit board, resulting in a cost-efficient, highly reliable lighting solution suitable for use in wall sconces or ceiling luminaires, either as new lighting installations or retrofits. The integrated LED driver makes for an extremely low profile, and now with universal voltage support, the same unit can be installed in virtually any setting. The Universal DirectAC LED Engine is suitable for open and enclosed luminaires, and luminaires with plastic and glass lenses.

“More of our customers are working on large construction and retrofit projects with

multiple luminaire types, so we are seeing more demand for one-size-fits-all LED light kits,” said Edwin Reyes, Product Director, LED Light Sources, for Fulham. “The Universal DirectAC LED Engine is designed to provide a single, self-contained, low-profile lighting solution that can be installed anywhere in 5 to 10 minutes.”

The DirectAC LED Engines are available in 10, 15, 23, and 34 W round configurations as well as a 15 W, 4 by 7-inch rectangular configuration. The DirectAC LED Engines offer a lumen maintenance of L70>54,000 hours, with a color consistency of 3 SDCM and a variety of color temperatures with an 80 CRI up to 90 CRI, making them ideal for replacing fluorescents. The units are leading/trailing edge dimmable from 100 to 10 percent. To reduce flicker, the DirectAC Engines have additional circuitry for use with 50/60 Hz power lines; flicker is below 30 percent when operated at line voltage meeting the CEC requirement for low flicker.

All units are suitable for installation in dry and damp locations, indoor or outdoor. The units are cURus, cULus Classified and ENERGY STAR® Luminaire 2.0 listed so they qualify for most rebate programs.

Fulham Releases Linear High Output DC LED Modules

New from Fulham is a range of Linear High Output LED modules providing an efficient, easy to install solution for high lumen linear applications. Featuring the latest high-efficacy high-output LEDs the new range of Linear High Output LED modules from Fulham deliver up to 198 lumens per watt and are a cost-competitive alternative to the typical LED modules.



Fulham's latest linear high output DC LED modules are the perfect choice for energy saving refurb

The LED board is mounted onto an aluminum extrusion to eliminate the need for additional heat sinks. They are available in CRI 80 and CRI 90, four power levels, three CCTs of 3000 K, 4000 K & 5000 K and easy, clip-on diffusers & end caps, making them a simple, flexible solution.

These new Linear High Output DC modules are an energy saving replacement for T5 fluorescent high output lamps and are ideal for use in many luminaire types. Push-in connectors allow these modules to be joined while maintaining equal LED spacing across the entire overall length giving complete flexibility in lighting installation lengths.

Modules are in 560 mm, 1120 mm and 1470 mm lengths and offer a wide variety of power ratings and lumen outputs, all with a full five year warranty. All modules are optimized for use with Fulham drivers and HotSpot LED emergency systems.

Linnea - LEDiL's Fabulous Linear Lighting Solution

The era of oil and candlelight have long gone but those pesky fluorescent light tubes remain and some might even think they are still relevant. Thanks to LEDs and some innovative optic design by our in-house team we have something better – much better.



LEDiL's new Linnea optics family consists of a bunch of optics fitting seamlessly together while maintaining a low profile

If you haven't already met them we'd like to introduce you to the Linnea family. They're an innovative bunch of optics fitting seamlessly together while maintaining a low profile. They're flexible too and work extremely effectively in a whole range of demanding indoor environments whether industrial, retail or office. And you can say goodbye to unevenly lit spaces as this family have a range of beam types with an ingenious microstructure surface delivering

homogenous color reproduction. Did we already mention how flexible this family is? They will work with all the most common 20 and 24 mm wide PCBs and any LED pitch; what more could you possibly ask for?

If you'd like to arrange a date to meet the Linnea family get in touch with your nearest LEDiL sales contact and they'll happily make all the arrangements. Don't worry, we don't do shotgun weddings but we can assure you, if you choose to have a relationship with any of the Linnea family it will be a marriage made in LEDiL.

Tridonic Accessory Package Optics for the Right Light Distribution

The Tridonic portfolio has been expanded to include a complete accessory package of lenses with various beam characteristics.



Tridonic's ACL Linear Cover optics for the DC LLE 24 mm

The following light distributions are possible with the optics:

- "Intense" is well suited for use in low-bay luminaires used in production halls and warehouses
- "Batwing" has been designed for luminaires that need to achieve high light homogeneity at a low ceiling height
- "DASY" has been specially designed for shelf lighting in shops. In addition to high vertical illuminance at eye level, the distinctive feature of this lens comes in the form of its even lighting of corridors. This lens enables corridors with a width of up to 2.4 m and a ceiling height of 3.5 m to be well lit
- For the illumination of specific highlights on the walls, the "ASY" lens creates a wall washer effect and high evenness with low color shift over the elevation angle at the same time

The lenses are suitable for all DC LLE 24 mm modules and are easy to mount. For the three-row LLE 55 mm modules, the company also provides the corresponding optics enabling various light distributions for applications in offices and shops.

This accessory package supports luminaire manufacturers in developing luminaires in a quicker and more cost-optimized way. Thanks to the high-quality PMMA materials used in the manufacture of the lenses, they achieve optical efficiency of up to 95%.

The lens geometry is flat at 13 mm and can also serve as protection against accidental contact for the LED module in the form of a cover. The 24 mm lenses are available in standard lengths of 1,200 mm, 1,500 mm and 1,800 mm, as well as in further special lengths.

Offline Constant Voltage and PFC Controller for Connected LED Lighting

Diodes Incorporated introduced the AL1788 high-performance offline constant voltage and PFC controller that has been developed to combine high power factor correction (PFC) with low total harmonic distortion (THD) and low standby power, making it well-suited for commercial applications and connected lighting requirements.



Diodes' new PFC controller offers a PFC >90 while providing a low 0.2 W standby power consumption

Based on a platform that supports both flyback and buck topology, the AL1788 is designed for primary side regulation (PSR), which removes the need for feedback optically coupled from the secondary side. This delivers outstanding performance, such as high efficiency of up to 91%, good line and load regulation of 2% over a full range of line and load regulation, and low standby power of less than 0.2 Watts.

With a PFC of >0.9 and lower standby power than its competitors, the AL1788 operates with an external MOSFET to deliver constant voltage to an LED load. The high power factor is achieved through constant on time operation, while its quasi-resonant mode valley switching method minimizes switching losses and provides outstanding EMI performance.

By exploiting PSR, the complexity of the secondary side is reduced, enabling a smaller overall profile suitable for solid state lighting installations. The output voltage is regulated when operating in constant-voltage mode through feedback provided by an auxiliary winding, coupled to the secondary side winding.

The AL1788 maintains its note-worthy PFC and THD performance across a wide input range over a load from 50% to 100%. The AL1788 features low start-up and operating current of just 3 μ A and 500 μ A, respectively (typical), combined with "Burst Mode" operation. The AL1788 enables users' designs to meet low standby power system requirements.

Comprehensive protections are integrated, including output-open protection and output-short protection, as well as overcurrent, overvoltage and over-temperature protection. Undervoltage lockout is also integrated.

The controller-only version of AL1788 is available now and provided in the SOT26 (SC74R) package, while the MOSFET regulator options will be supplied in an SO-7 package and will be released in 2018. Both are lead, halogen, and antimony free and fully RoHS compliant.

Tristimulus Sensor Supports Accurate Photobiologically Active Light Measurement

ams, a leading worldwide supplier of high performance sensor solutions, introduced the AS7264N, a tri-stimulus sensor which provides measurements of color that closely match the human eye's response to the visible light spectrum. The new sensor also accurately measures blue-light wavelengths, which researchers have linked to important health effects such as disruption or management of the circadian rhythm, accelerated eye aging, and eye strain.



ams' new AS7264N tristimulus true color sensor from the AS72xx family supports accurate measurement of photobiologically active light addressing the interaction between light color and human health

Provided in a compact 4.5x4.7x2.5 mm land grid array (LGA) aperture package, the AS7264N's small size makes it well suited for luminaires and connected sensor packs; it is expected to be used in emerging applications of human-centric lighting and smart building control. The new sensor is based on the successful ams AS72xx product platform which includes a complete family of light and color sensors from near-UV to near-IR for spectral and lighting applications. The family's tri-stimulus color sensors use unique on-wafer silicon interference filters to create individual spectral channels matching the characteristics of the XYZ standard observer model as specified by the CIE 1931 standard. The AS7264N supplements that, with two additional blue light filters, provide the capability to accurately measure the intensity of blue light at both the 440 and 490 nm wavelengths.

The small, low-cost, board-mounted AS7264N allows the implementation of novel light control functions in luminaires, displays, and smart building automation or management systems. By incorporating an AS7264N into their product, lighting and building automation sensing solution manufacturers are able to deliver real-time smart color monitoring to measure and respond to end-users' exposure to blue light wavelengths.

Like other members of the AS72xx series, the AS7264N provides easy-to-use digital color measurement outputs over an I²C interface. The device's silicon interference filters, which feature minimal drift over time and temperature, enable lifetime end-device calibration. Programmable on-chip LED drivers enable direct control of synchronized electronic shutter functionality.

"With true color sensing and precise spectral measurements at wavelengths with active photobiological influence, the AS7264N serves a wide range of applications including

ambient light characterization and light exposure data collection for commercial, residential, and industrial lighting applications. This solution will help manufacturers get to market quickly with applications that address the interaction between light and human health," said Tom Griffiths, Senior Marketing Manager for Lighting and Spectral Sensors at ams.

TI's New Automotive LED Lighting Controller Without Internal MOSFET

Texas Instruments introduced the first 3-channel high-side linear automotive light-emitting diode (LED) controller without internal MOSFETs which gives designers greater flexibility for their lighting designs. The TPS92830-Q1's novel architecture enables higher power and better thermal dissipation than conventional LED controllers, and are particularly beneficial for automotive LED lighting applications that require high performance and reliability.



Achieve higher power, better reliability and thermal dissipation in automotive LED lighting systems with a controller and external MOSFET

The TPS92830-Q1 offers several features and benefits.

Flexibility:

The on-chip pulse-width modulation (PWM) generator or PWM input enables flexible dimming. Designers can use either the analog control or PWM to manage an output current of more than 150 mA per channel, to power automotive rear combination lamps and daytime running lights.

Improved thermal dissipation:

By pairing the LED controller with an external MOSFET, the designer can achieve the required high power output while distributing the power across the controller and MOSFET to avoid system overheating. By retaining linear architecture, the TPS92830-Q1

provides improved electromagnetic interference (EMI) and electromagnetic compatibility (EMC) performance.

Greater system reliability:

Advanced protection and built-in open and short detection features help designers meet original equipment manufacturer (OEM) system reliability requirements. The output current derating feature protects the external MOSFET under high voltage conditions to ensure system reliability.

Conventional LED drivers integrate the MOSFET, which limits designers' ability to customize features. With that type of driver, designers often must make significant design modifications to achieve the desired system performance. The TPS92830-Q1 LED controller's flexible on-board features give designers the freedom to select the best MOSFET for their system requirements. With this new approach, designers can more quickly and efficiently optimize their lighting power designs for automotive system requirements and desired dimming features.

The TPS92830-Q1 expands TI's portfolio of LED drivers, design tools and technical resources that help designers implement innovative automotive lighting features.

Inventronics Expands Switch-Selectable LED Driver Family

Inventronics has introduced a family extension of switch-selectable IP67 LED drivers that provide the flexibility of adjustable output currents without any software or programming set up. This is accomplished with a 4-position switch that can be used to set up 16 different output current levels. The switch is accessed through a secure cover which allows the driver to maintain an IP67 rating which is

ideal for harsh indoor and outdoor conditions such as street, area, bay and tunnel lighting.



Inventronics' new EUP-200/240SxxxST/SV series is IP67 rated and offers switch-selectable output current in 16 steps

With the expansion of the EUP-200SxxxST/SV and EUP-240SxxxST/SV series, the EUP family now provides 5 different power levels with the existing series of the 75 W, 96 W and 150 W models. The EUP family is designed for those who desire the IP67 rating and higher surge protection but do not require dimming controls or other enhanced features. By removing those features and keeping the adjustable output current, there is now a simplified offering that provides design flexibility and a reliable performance.

The EUP-200SxxxST/SV and EUP-240SxxxST/SV operate from 90-305 Vac input and delivers full output power at output currents from 700-6700 mA. Each series is highly reliable with a superior level of built-in surge protection: 6 kV DM, 10 kV CM, over-voltage protection, short-circuit protection and over-temperature protection. The lifetime of these drivers is calculated to be at least 84,000 hours when operating at 80% load.

This new family is approved to UL, FCC, TUV, CE, CB, ENEC, PSE, BIS, CCC and KS certifications. Production quantities of the EUP-200SxxxST/SV and EUP-240SxxxST/SV are available now.

Upowertek Announces DALI Compatibility for 50-400W BLD Series LED Driver

DALI (digital addressable lighting interface) protocol is very commonly used for intelligent lighting control according to IEC 62386 from the fluorescent age and many retrofitting projects using LED lights require DALI compatibility. Upowertek recently announced that BLD series support DALI control, and still own all the existing features like NFC programming without having to power on the driver and dim to off with low standby power.

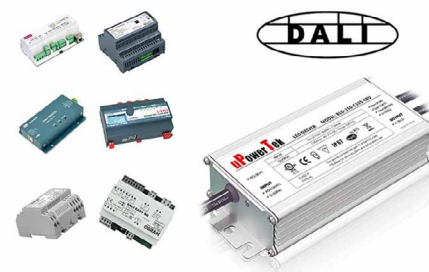

DALI compatibility of Upowertek's 50-400 W BLD series LED drivers is tested with DALI masters from the most important brands

Features:

- Touch Free and Passive Programmable
- Fully Tested with Probit (IEC 62386 Tester)
- Fast and Safe
- IP67 waterproof
- Compact Size
- UL Class P Rated
- Extremely Low Standby Power
- Great Surge Immunity 10 Kv
- 100,000 Hour Life @ Tc=75°C
- 7 Year Warranty @ Tc=75°C
- Airset™ NFC Programmability
- 0.5 W Standby Power
- 12 V 300 mA Auxiliary Power to PowerControllers and Fans
- ENEC/CB/CCC SELV Output According to EN 61347-1, 61347-2-3, 61347-2-13, 62384



EnOcean Wireless Constant Voltage LED Dimming Module

GRE Alpha's EnOcean(R) dimming module allows for smooth, flicker-free dimming of lighting fixtures using any of EnOcean(R)'s certified Energy Harvesting Wireless Switches. GRE Alpha's series of dimming modules complies with the latest EnOcean (R) protocols and support frequencies for North America 902MHz, Japan 928MHz, Europe and China 868MHz. The dimming module is compatible with any constant voltage LED driver and can be extended and allows for seamless integration into existing LED lighting systems of new building automation projects with ease.

For more details, please visit www.grealpha.com



These new DALI dimmable drivers are fully tested with DALI masters from Philips, Osram, Helvar, Tridonic, Honeywell, etc. and the great compatibilities will benefit the end users who are designing the lighting systems for high bays, road lights, tunnel lights and grow lights.

E-Lemon - The First Driver with integrated IP67 Connectors

E-Lemon has developed and marketed an innovative LED driver with integrated IP67 waterproof connectors, which allows leak-proof installations in your garden or bathrooms.



E-Lemon's latest LED driver simplifies IP67 waterproof installations while being highly efficient and sustainable

Main Features:

- E-Lemon driver is safer, quicker and easier system to make IP67 waterproof installations in your garden or bathrooms
- This revolutionary LED driver, highly efficient and sustainable, guarantees the success of tests by TÜV and CE certificates
- E-Lemon is a unique and fully customizable technology, according to your needs

Major Specifications:

- LED driver with shock-resistant housing and IP67
- Suitable for installation in humid environments, specially ready to be buried:
 - Outside luminaries, mainly buried, also in flood areas
 - All LED drivers include 2 clips for fix on surface
 - All the E-Lemon's LED drivers are equipped with all necessary physical and electrical protections
 - The compact design and small approach dimensions allow it to pass through the established hole for the lighting in most cases
- Quick and easy installation
- Class II protection against electric shock
- IK10 shock resistance, IP6X dustproof and IPX7 waterproof. It can easily be installed outdoors or indoors
- Compact size
- Input and output standard terminal blocks (until 2.5 mm) on opposite sides
- Input and output cable glands for wires from Ø5 to Ø 10 mm
- Electronic components totally sealed on the main housing

With the E-Lemon drivers, you can make waterproof installations more quickly and completely secure than conventional drivers. Thanks to its independent LED driver, E-Lemon has multiple applications in outdoor/indoor installations with their high quality electronic components made by EagleRiseR, main housing filled with

EPISTAR

Standing on the shoulder of giant

SEE FURTHER



Co-activation
SERVICE

Learn more about our
Co-activation Service Model

Epistar Corporation
21, Li-hsin Rd., Hsinchu Science Park,
Hsinchu 300, Taiwan
T : +886 3-567-8000 F : +886 3-579-0801
www.epistar.com E : sales@epistar.com



Website Facebook

resin for warranty IP67 waterproof, double rubber on cable glands, standard terminal blocks and a shock-resistant body made by nylon. Additionally, all LED drivers include two clips for fix on surface.

Designing new products has never been easier! With the E-Lemon driver you shouldn't have to think about the space to hold the driver and its temperature limits, since it is usually lower than the LED. It means the lighting fittings can be much smaller; you only need heat sink in the LED.

Additionally, E-Lemon drivers comply with all safety and protection standards as RoHS and RAEE.

Inventronics LED Drivers Without E-Cap for Longer Lifetimes

Inventronics has announced the release of a new series of LED drivers with a revolutionary design backed by a 10-year warranty. These Controls-Ready, programmable drivers were specifically designed with the intentions to provide a robust, industry-leading driver for those applications requiring extremely long operation life. They are ideal for industrial, bay, street, roadway, area and tunnel lighting.



Inventronics' new EUD-DTL/DVL drivers are built without e-caps for extended lifetime

The new EUD-DTL/DVL drivers are the result of several years of development and examination of the weak links in driver design. One unique aspect is that it eliminates the main weakness in LED drivers; the electrolytic capacitor. Electrolytic capacitors are adversely impacted by the elevated temperatures commonly found in solid state lighting fixtures. By removing the use of electrolytic capacitors in addition to introducing other novel design and manufacturing techniques, the drivers have an ultra-long lifetime.

The new series offers several models supplying 96 W, 150 W and 240 W power ranges and operate over a 90-305 Vac input voltage range. They provide a high-level of design flexibility with programmable output currents from 450-6700 mA and multiple dimming options including 0-10 V, PWM and 3 timer options. This helps to reduce inventory and removes the need to design-in a new LED driver for multiple configurations.

The EUD-DTL/DVL series is controls-ready and ideal for operation with a wide variety of sensory and controls since it's equipped with dim-to-off capabilities and an always-on 12 V auxiliary supply sourcing up to 200 mA. This allows them to power Inventronics controls modules directly, bypassing the power and voltage restraints associated with power packs and AC relays.

In addition to the new, more robust and innovative design, the series is IP67 rated (DTL version is also TYPE HL), which is great for environmentally harsh indoor and outdoor conditions such as street, area, bay and tunnel lighting. The EUD-DTL/DVL series also features over-voltage, over-temperature and short-circuit protection, plus a higher level of built-in surge protection: 6kV line-to-line and 10 kV line-to-earth. These drivers implement the new external over temperature protection for LED modules, another key factor in significantly improving reliability and extending lifetime.

The new series is approved to UL, FCC, ENEC, CCC, TUV, CE, KS and CB standards. Production quantities of the EUD-096SxxxDTL/DVL, EUD-150SxxxDTL/DVL and EUD-240SxxxDTL/DVL series are available now.

SSC Introduces Acrich Based Compact LED Driver with very high Power Density

Seoul Semiconductor, a global leader and innovator of LED products and technology, has developed an ultra-compact LED driver series with a power density 5x higher than conventional LED drivers. Based on the patented Acrich technology, the MicroDriver Series delivers more than 24 W of output power with a power density of 1.25 W/cm³, compared to existing drivers at 0.25 W/cm³. Measuring just 38x28x20.5 mm, it is 80%

smaller than conventional LED drivers, giving lighting designers the ability to develop ultra-thin and novel luminaires with flicker-free operation.



SSC's new MicroDriver Series LED drivers are based on Acrich Technology and the recently introduced NanoDrivers

"The new MicroDriver Series LED drivers will have a significant impact on external converters, enabling lighting design engineers to dramatically reduce the size, weight and volume of their luminaires," explained Keith Hopwood, executive vice-president at Seoul Semiconductor. "This breakthrough in size reduction for the MicroDriver Series is the result of the company's continuing investment in Acrich high voltage LED technology, delivering benefits for customers in smaller size, increased efficiency and lower costs."

The MicroDriver Series LED drivers are ideal for lighting designs such as wall sconces, vanity lights, downlights, and flush-mounted lighting fixture applications. The MicroDriver Series' smaller size facilitates the conversion of these applications to LED light sources, which was not previously possible due to bulky conventional LED drivers, making halogen lamp replacement possible without the need for a large volume recess for the driver, or a reduction in light output.

The MicroDriver Series LED drivers are ideal for luminaire designs up to 2,400 lumens, and their compact size enables integration of the lighting control circuitry with the external converter. This gives lighting designers the capability to mount more light sources on the board or reduce the total size of the fixture and mounting plate.

The resulting decrease in the LED drivers' physical size has significant business implications for the lighting industry, giving lighting designers the ability to shrink the size of light fixtures by as much as 20%, which reduces shipping and storage costs. Because conventional LED drivers are both

heavy and bulky, they are typically shipped via sea freight from manufacturers in Asia to European and North American fixture companies, with transit times up to six weeks. The MicroDriver Series LED drivers are small and lightweight enough to make airfreight practical and economical, reducing lead time and streamlining the overall supply chain.

The MicroDriver Series is rated to IP66, and is available in 10 models, rated for 8 – 24W in 120V or 230V versions, for LED assemblies from 900-2400 lumens. The drivers are CE recognized, provide flicker-free operation for phase-cut dimmers, and are compliant to California Title 24, enabling lighting designers to meet the most challenging design requirements, including low flicker, high power factor, Class B EMI and 2.5kV surge.

Inventronics Expands Robust LED Drivers with Market-Leading Input Protection

Inventronics has expanded their EDC series of constant-current LED drivers designed specifically for the Indian market and those markets who face challenging power regulations to include 100W models. They help protect against poor quality supplied to the LED driver, reducing maintenance costs and safeguarding the luminaire.



Inventronics' new 100 W member of the EDC constant-current LED driver series is especially designed to withstand temporary input voltage fluctuations up to 440 Vac

The EDC-100 series offers a high level of market leading input protection capable of handling challenging power conditions, such as frequent power outages or operating from a backup power generator, while providing a reliable, cost-effective solution. They provide a high level of protective functions, including Input Over Voltage Protection (IOVP) and Input Under Voltage Protection (IUVP).

They are capable of handling temporary voltage increases up to 440 Vac up to 48 hours. The new EDC-100S105SV models are certified to BIS, CE, CCC and KS standards and meet the India EESL standards. The EDC series provides an IP67 rating and is equipped with a compact metal case enabling them to protect against dust and particles and a high level of protection against water and humidity. Total Harmonic Distortion (THD) of this series is under 10%.

The EDC-100S105SV series includes 3 models of constant-current drivers that can supply up to 100W at output currents from 700 to 1050 mA with a full-load efficiency up to 91%. The calculated lifetime of these drivers are 96,000 hours at 70°C. They operate from 140-305 Vac, are suitable for independent use and Class I Luminaires. Production quantities of the EDC-150S105ST/SV are available now.

Lambda Research Announces TracePro® 7.8.3 and the Early Visibility Release 2018

Lambda Research Corporation, a leading designer and publisher of illumination and optical design software, announces the release of TracePro 7.8.3 and the Early Visibility release of its flagship TracePro software.

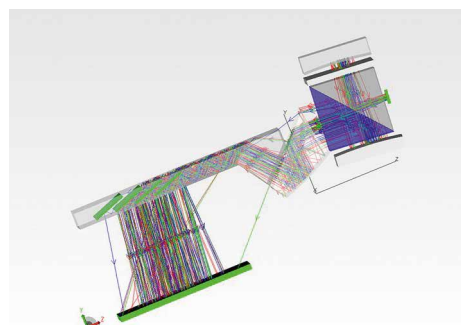

Lambda Research's latest TracePro versions, the TracePro® 7.8.3 and the early visibility TracePro® 2018 release, are fully packed with new features

Some of the new features/enhancements in TracePro 2018 EV:

- ACIS release R28 with improved optional STEP & IGES translators
- Upgraded HOOPS graphic engine for improved system visualization
- Improved RepTile™ coincident surface algorithm for TracePro Expert users

Some of the new features/enhancements in TracePro 7.8.3:

- Monte Carlo Tolerancing has been added to the 3D interactive modeler
- New 3D modeler capabilities
 - Advanced Sweep Body Editor
 - Measurement Tool
 - New path selection including helical, square spiral, free helix
- Rounding radius added to periodic and Fresnel segments to accurately model optics with chamfers and fillets
- New Photorealistic Rendering Options with the ability to save Luminance Data
- New Utility: Surface Property Generator

TracePro 7.8.3 and 2018 further enhance the most powerful and sophisticated optical analysis and design software available today. TracePro streamlines the prototype-to-manufacturing process by combining an intuitive 3D CAD interface, superior ray tracing performance, advanced utilities, and seamless interoperability with other mechanical design programs.

GL Optics' Spectrosoft Supports the New Color Fidelity Index Rf

GL Optic has upgraded its software GL Spectrosoft Pro to meet the latest requirements of the international CIE (International Commission on Illumination). The number of reference colors used to calculate the Ra value has been increased from 8 to 99 reference colors to calculate the new Rf value. All LED products can be compared objectively in terms of color rendering quality. The new software can be used with all products of GL Optic.



GL Optic's latest light measurement software for GL spectrometers supports new standards and color fidelity index

At the end of April 2017, the CIE (International Commission on Illumination) published a new standard – CIE 224:2017 Color Fidelity Index –

for accurate scientific use on a new color fidelity index called Rf. This index takes into account the spectral characteristics of white LED light sources. To develop the new methodology, thousands of different LED sources and luminaires were analyzed and the number of reference colors used to calculate the Ra value was increased from 8 to 99 colors to calculate the new Rf value. The new index was introduced as a supplement to the Ra value for scientific purposes. All professionals in the lighting industry and discerning customers can now compare and select LED products more objectively in terms of color rendering quality.

GL spectrometers are used to measure any light sources. With the new software GL Spectrosoft Pro, the measured values can be analyzed and the new Color Fidelity Index can be determined.

PANOS Infinity Sets New Performance Benchmarks

The Vorarlberg-based lighting manufacturer Zumtobel and lighting technology expert Cree have been working together on dedicated LED technology for the PANOS infinity series since 2010. Now, a new version of the luminaire will feature the very latest Cree TrueWhite® technology. Available from January 2018, this brand-new variant is set to further enhance the unparalleled combination of high luminaire efficiency and excellent color rendering, while also helping PANOS infinity maintain its market-leading position with excellent lumen maintenance and improved color stability over the service life of 50,000 hours.



The integration of Cree's latest technological advancement, carefully configured to meet the specific needs of Zumtobel, will see the pioneering LED downlight PANOS infinity break new ground

A jointly developed integrated LED board solution is optimized for use in Zumtobel's PANOS infinity LED product family. Based on the Cree TrueWhite® technology, a patented spectral engineering-based system for producing white light with LEDs, the customized PANOS infinity blends light from red and unsaturated yellow XLamp® XP-G3 LEDs to create warm white light. Compared to traditional chip-on-board solutions, this red and white multichannel technology delivers superior results in terms of efficiency and light quality, enabling PANOS infinity from Zumtobel to strengthen its status as "best in class" in the downlight sector.

The integration of Cree's latest technological advancement, carefully configured to meet the specific needs of Zumtobel, will see the pioneering LED downlight break new ground. The optimized technology enables the PANOS infinity LED product family to once again raise the efficiency benchmark in downlight applications with a luminaire efficiency of up to 135 lm/W and color rendering of CRI 90+, combined to achieve a light yield that is truly unique in this sector. Improved color tolerance and color deviation values (MacAdam 2 in place of MacAdam 3) represent further important benefits of this exciting new generation product. Additionally, reducing the drop in luminous flux to just five percent over a service life of 50,000 hours (L95) means that any changes in the light level are barely visible.

Eaton's Connected Solutions for Retail, Hospitality, Commercial and Specialty Spaces

Power management company Eaton recently launched the RSA MRZ family of architectural recessed multi-head luminaires, offering a wide breadth of features and options including Eaton's WaveLinx or LumaWatt Pro sensors, which enable a full spectrum of wireless and connected lighting solutions. The family is designed to provide accent, wall wash and ambient lighting in retail, hospitality, commercial and specialty spaces including museums, churches and high-end homes.

Eaton's MRZ family is available with one, two, three or four integral LED head configurations and a choice of three optical distributions including 25 degrees (narrow flood), 40 degrees (flood) and 55 degrees

(wide flood) to accommodate accenting needs. Each adjustable fixture head allows for 45-degree tilt and 365-degree rotation for full aiming flexibility, putting the light exactly where it's needed. These optics are also interchangeable in the field. In addition, a variety of industry standard lenses and louvers are available to help shape the light distribution including Linear Spread Lens, Soft Focus Lens, Hex Louver and Snoot.



Eaton's next generation recessed multi-head LED luminaires are providing new opportunities in retail, hospitality, commercial and specialty lighting

Options:

- A choice of 2700 Kelvin (K), 3000 K, 3500 K and 4000 K color temperatures and 80+ or 97+ color rendering index
- Three housing and trim color option choices of white housing and white trim; black housing and black trim; and black housing with white trim
- Multiple lumen packages ranging from 250 to 1700 lumens per head
- An emergency battery pack option to aide in fixture conditions needing egress outputs

The fixtures are available with a flanged trim option for acoustical tile, which features a slim 0.75-inch trim to help hide any imperfections from cutouts of ceiling materials or a mud-in trim for gypsum board ceilings for a clean and trim less look. A tapered trim of 0.8-inch helps contractors have minimal depth variance.

The option to include Eaton's WaveLinx system provides a simple-to-install, wireless, code-compliant and cost-effective connected lighting system that allows building managers to easily adjust settings through a mobile app with no need to go back into the system interface – even after the project has finished. Eaton's optional, advanced LumaWatt Pro wireless connected lighting system helps customers maximize potential energy savings by incorporating the MRZ fixtures in a distributed network of

smart LED lighting fixtures with wireless sensing capabilities that capture real-time data on lighting energy performance, space utilization, real time location services and building system integration.

ULT Introduces New Professional Retrofit Kit

Universal Lighting Technologies, a global leader in lighting and a member of the Panasonic Group, is expanding its continuum of LED retrofit solutions with its Everline® LED Professional Retrofit Kit (PRK). The pan-style fixture retrofit kit is designed to replace existing fluorescent solutions including prismatic troffers, direct/indirect luminaires, volumetric luminaires and parabolic luminaires.



Universal Lighting Tech's latest addition to the Everline® series offers many features for professional retrofit applications

"There's a large base of aging recessed fluorescent lighting that is a leading candidate for retrofit versus full fixture replacement," said Stephanie Boyle, senior director of product management for Universal's Everline LED retrofit solutions. "The Everline PRK family will offer an easy to install and energy efficient LED troffer upgrade with less disruption because it goes right into the existing fixture housing."

The Everline PRK, equipped with a 0-10 V dimmable LED driver, will retrofit 1-by-4 foot (PRK14), 2-by-2 foot (PRK22) and 2-by-4 foot (PRK24) fluorescent recessed fixtures to high-quality Everline LED. It comes in four Color Correlation Temperature (CCT) options including 3000 K, 3500 K, 4000 K and 5000 K.

With a range of configuration possibilities and a five-year limited warranty, Everline PRK upgrades the light distribution as well as the light engine, making it an ideal option for installers working on a variety of applications including offices, classrooms, lobbies, corridors and other commercial and

institutional spaces. The light engine, a top-performing Everline LED driver and high-efficacy LED modules, is easy for technicians to install and will provide controllable lighting for virtually any recessed retrofit.

"Universal has made it easy to retrofit fluorescent to LED, to qualify for available rebates and to save energy," stated Boyle. "Select Everline LED Professional Retrofit Kits are DesignLights Consortium (DLC) Premium Qualified and all have a 95,000 hour rating at L70, considerably reducing maintenance costs."

The Everline PRK's design features a heavy gauge steel housing and aluminum LED tray finished with corrosion- and scratch-resistant white enamel that offers impressive durability and improved optics. The kit, which is UL Classified 1598C in the United States and Canada and specified for 120-277 VAC or 347 VAC power configurations, also offers excellent light quality with a Color Rendering Index (CRI) of 80.

Luminis Introduces Oculus Exterior Recessed Downlights

Luminis, an established innovator and manufacturer of specification grade lighting solutions announced the release of its Oculus LED lighting product family. Oculus is a recessed downlight designed for outdoor, under canopy applications where resistance to weather, light output and directional aiming are important. It is the first product of its kind to combine all three features.



Luminis' Oculus is an IP66 rated a recessed downlight for outdoor applications

Oculus is suitable for harsh outdoor weather conditions and is IP66 rated. It has a fully adjustable light module providing 360° rotation and 30° tilt angle for precise aiming

of light. It has a screw-less, low profile trim providing a clean, seamless architectural appearance. The trim is available in a range of finishes to suit any aesthetic. Oculus is available in two aperture diameters, 6" and 8".

Features:

- 360° rotation for precise directional aiming of light
- IP66 rated for performance in extreme weather conditions
- Up to 6000 delivered lumens
- Unique integral tilting mechanism which allows forward-back adjustability
- Standard 4000 K CCT, plus 2700 K, 3000 K, 3500 K and 5000 K options
- 80 CRI
- Standard reflector optic - 20° (OC750), 29° (OC950)
- 3 optional reflector optics; narrow, flood, and wide
- Available in 6" and 8" aperture diameter to fit various applications
- Optional linear spread lens for asymmetric distribution
- Optional regressed light module
- Lifetime beyond 130,000 hours
- Standard 0-10 V dimmable
- Trim available in various colors
- Standard 5-year warranty

Installation and maintenance is facilitated with multi-tab ceiling anchor points and a gasketed service door for easy driver access.

Oculus has a standard 4000 K color temperature, with 2700 K, 3000 K, 3500 K and 5000 K options. It has a CRI of 80 and delivers up to 6000 lumens depending upon the model and options selected. It has three reflector optics options; narrow, wide and flood. It is fully dimmable, boasts a lifetime in excess of 130,000 hours and comes with a standard 5-year warranty.

Lumibright's Lumipro Profiles for Modular Linear Lighting

This ground-breaking modular lighting system is designed for creating unimaginable light architectures to make the environment marginal yet indispensable. The brand new ultra-lightweight linear profiles are versatile enough to meet any design needs guaranteeing extraordinary visual light comfort for every application beyond ordinary imagination.



Lumibright's modular lighting system is designed for creating unimaginable light architectures like in this application for a car dealer

With an innovative, sleek, clear body design, profile linear lighting spread soft indirect light emissions over walls or ceiling or floor from flat surfaces creating paths of light with perfect uniformity and unlimited lengths. LED aluminum profiles are available in variety of depth and length according to clients need to blend into every lighting project and can be fitted in either single module formats or joint-free long continuous rows of uninterrupted lines of light.

The Flexible version of LED aluminum extrusion that is re-shapeable ideally suit curved lighting applications making the lighting design overwhelmingly captivating. They also come in varied colors of LED with regulated intensity of lights and dimming capabilities. Minimalism, modularity and ease of installation characterize the LED profiles that are extremely easy to install, transforming any space with class and refinement. Being a perfect fusion of performance, flexibility and sparkling nominal design, all in a single product the LED Profiles ensure optimal performance, endurance and low energy demand.

Applications:

The soft glare-free bi-directional light protruding from the light-weight linear profiles achieve amazing aesthetical incredible efficacy, which allow designers the freedom to use this application even in the most demanding and hard to reach areas.

The product can be mounted individually, or in long continuous lines as a suspended pendant luminaire, or directly to the surface of a wall or ceiling, and as recessed mounted using the frames, even on staircases, handrails or furniture such as shelves ends, showcases, wardrobes, jewelry racks etc.

They are perfectly suited for residences, commercial offices, retail outlets &

showrooms, auditoriums, supermarkets, educational institutes, service & hospitality sectors, much more.

World's First Industrialized LiFi Luminaire

As result of a co-development partnership with the Scottish company pureLiFi, Lucibel presents the world's first industrialized LiFi solution on the market. LiFi (Light Fidelity) is a communication technology through modulated LED light that enables data exchange between a specific LED lighting fixture and a computer, making Internet access possible. The performance of this bidirectional broadband connection has been multiplied by 4 since the installation of a Lucibel prototype in June 2015. The reception of data transmitted by the lighting fixture is done via a LiFi USB key whose size has been divided by 5 since the initial prototype installation.



By positioning itself as a complimentary technology to Wifi, this smart and connected light is taking on a new dimension thanks to Lucibel

According to the American research institute Gartner, the demand of Internet of Things (IoT) will come to more than 50 billion devices by 2020 to 2022 compared to 5 billion today, which will lead to an exponential growth in the volume of data exchanged. LiFi technology has positioned itself as one of the wireless networking technologies that will enable the development of IoT.

The LiFi luminaire and USB key, resulting from the partnership between Lucibel and pureLiFi, will be exclusively manufactured by Lucibel in France at its industrial site in Barentin (Normandy). This will be the case whether marketed by Lucibel or pureLiFi.

Edouard Lebrun, Chief Innovation Officer at Lucibel says: "The production of this LiFi solution in France forms part of Lucibel new

industrial strategy implemented for over 2 years. Indeed, thanks to the relocation of its manufacturing facility in France, Lucibel has been able to co-develop, industrialize and market its LiFi solution in less than 15 months, which gives it the only solution of the market that can be easily integrated in a building."

As a first step, the Lucibel LiFi solution aimed essentially at professionals to offer them Internet access mobility where wifi is not available or badly deployed.

Harald Burchardt Chief Operations Officer at pureLiFi says: "The fruition of our important partnership marks the realization of new and significant business opportunities for innovators in the lighting industry like Lucibel. With pureLiFi and Lucibel powering this new generation of data enabled lighting we can now begin to see the real life application of this emerging technology, offering safe and secure wireless communications on the path to unlimited bandwidth and unlimited data."

Alistair Banham, Chief Executive Officer (CEO) at pureLiFi says: "Our partnership with Lucibel, who are at the forefront of lighting innovation, allows us to accelerate LiFi's real world commercial implementation. This partnership between two innovative companies has resulted in a worlds-first LiFi integrated luminaire and this is a step towards LiFi's future as a 5G technology."

Thanks to its decisive advantages (impossibility to remotely hack a LiFi network, absence of radio waves potentially harmful to human health...) priority deployment targets are places where:

- The data security is a major issue (banks, defense, R&D centers, executive offices, private security...).
- Radio waves (wifi) are not permitted (hospitals, nursery, schools, industry...)
- The density of users is very high (co-working space, airport, hotel, meeting room, convention space...)
- For more than two years, Lucibel has been structuring its marketing strategy through:
- The recruitment of a dedicated team specialized in networks and IT,
- The implementation of strategic partnerships with major players in the real estate or IT sectors
- The qualification of its LiFi solution by large, general or specialized IT integrators.

The results are promising with big names already seduced by this innovative solution:

Nexity, first integrated player on the real estate market in France (housing, offices, managed residences, hotels, shops...), is the first end user of the industrialized LiFi luminaire. A collaboration and an operational partnership that Loïc Daniel, Deputy CEO of Nexity Business Property, welcomes: "The innovation strategy of Nexity is illustrated by a will to meet the needs of occupants for connected living and work spaces, flexible and oriented to their well-being. We congratulate ourselves on this approach of co-innovation with a company as Lucibel, who will be a supplier of new solutions for the real estate of tomorrow."

Microsoft is also implementing the LiFi solution at its innovation center in Issy-les-Moulineaux in order to share with its clients the opportunities offered by the technology.

SLMS (Schneider Lucibel Managed Services, Joint-Venture between Schneider Electric and Lucibel) also markets the solution through its "LiFi as a Service by SLMS" offer.

Frédéric Granotier, President and Founder of Lucibel, is confident: "This major breakthrough enables Lucibel Group to become the link between the world of lighting and the one of IT. With the integration of the LiFi technology in smartphones and tablets, expected within 2-3 years, the private individual market segment will also be opened."

LiFi: How it works

In practice, a RJ45 wire is connected to the lighting fixture that then becomes a head end, and a LiFi key is connected to the computer USB port.

Technical performances:

The "LiFi by Lucibel" solution enables the deployment of a complete wireless network through a bidirectional transmission of 42 Mbps. The "LiFi by Lucibel" system offers a mobile connection within a network while simultaneously supporting multiple access and "handover."

Each LiFi luminaire can serve several LiFi stations simultaneously. The "handover" function allows users to automatically have a stable connection from one lighting fixture to another.

In addition to traditional power supply, the "LiFi by Lucibel" luminaire is optionally compatible POE / POE+ and High Power POE in order to minimize the necessary wiring for the deployment of a LiFi network infrastructure.

Apure Launches New MINUS Architectural LED Lighting Fixtures

Apure, an innovator and manufacturer of state-of-the-art architectural lighting, announced the launch of its new MINUS product series. With an ultra-thin profile for minimal recess and an almost imperceptible aperture, the MINUS is designed to enable higher ceilings and architectural flexibility. Designed by the renowned PORSCHE DESIGN STUDIO, it combines performance with a clean, sophisticated aesthetic. It has proprietary precision optics

InterLumi

The lighting trade fair can be your local partner

Panama

Light it up
your market in Latin
America & the Caribbean!

11-13 July, 2018

ATLAPA Convention Center, Panama

www.inter-lumi.com



engineered to distribute light very evenly without any glare. The fixture itself is invisible to the eye, a breakthrough in lighting technology. And it is available in two form factors; MINUS ONE, a round finish, and MINUS TWO, a square finish.



Apure's MINUS is a minimal recess, sleek design and discreet light source that provides architectural flexibility

Features:

- MINUS ONE aperture of just 10 mm
- MINUS TWO magnetic louver of 25 mm square
- Recess only 19 mm
- Lumen output of 1140 from source
- 20° or 40° beam angle options
- Glare-free
- Low voltage
- 50,000 hour lifetime at 100% (LM80)
- Fully dimmable, 1-100%
- Three color temperature options, 2700 K, 3000 K and 4000 K
- 80 or 90 CRI
- 5 fixtures per 100W transformer
- High performance LED light source

Designed to save overhead space, the MINUS addresses the trend for modern, higher ceilings. Its minimal recess requires just 3/4 inch (19mm) space enabling the raising of ceiling height. As well as being an ideal choice for new, modern construction projects, the MINUS can be installed with just furring strips, maintaining high ceilings in renovation projects or new constructions.

“MINUS is a high performance fixture that is designed to blend with its surroundings,” said Uli Petzold, Apure founder and CEO. “It offers architectural flexibility, enabling ceilings to be raised higher and delivering more natural light in hallways, bathrooms, kitchens and even over dining tables. Offices can now be illuminated with glare free lighting that boosts the efficiency of employees. It’s a good option for renovations where architects are looking for a more modern environment, with space and a feel of natural light.”

The MINUS product is offered with a 2700 K, 3000 K, or 4000 K CCT with 80 or 90 CRI. It is fully dimmable, flicker free down to 1% and using proprietary microchip technology boasts a lifetime of 50,000 hours at 100% (LM80). Lumen output from source is 1140 and 5 fixtures can be powered by one 100 W transformer.

Atomistic Calculations Predict that Boron Incorporation Increases the Efficiency of LEDs

High-power white LEDs face the same problem that Michigan Stadium faces on game day - too many people in too small of a space. Of course, there are no people inside an LED. But there are many electrons that need to avoid each other and minimize their collisions to keep the LED efficiency high. Using predictive atomistic calculations and high-performance supercomputers at the NERSC computing facility, researchers Logan Williams and Emmanouil Kioupakis at the University of Michigan found that incorporating the element boron into the widely used InGaN (indium-gallium nitride) material can keep electrons from becoming too crowded in LEDs, making the material more efficient at producing light.

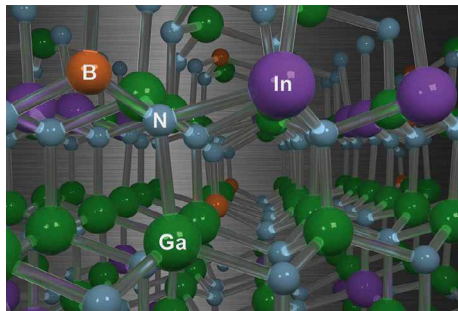

This is the crystal structure of a BInGaN alloy (Credit: Michael Waters and Logan Williams)

The image shows the crystal structure of a BInGaN alloy. Using atomistic calculations and high-performance supercomputers at the NERSC facility, Logan Williams and Emmanouil Kioupakis at the University of Michigan predicted that incorporating boron into the InGaN active region of nitride LEDs reduces or even eliminates the lattice mismatch with the underlying GaN layers while keeping the emission wavelength approximately the same. The lattice matching enables the growth of thicker active regions and increases the efficiency of LEDs at high power.

Modern LEDs are made of layers of different semiconductor materials grown on top of one another. The simplest LED has three such layers. One layer is made with extra electrons put into the material. Another layer is made with too few electrons; the empty spaces where electrons would be are called holes. Then there is a thin middle layer sandwiched between the other two that determines what wavelength of light is emitted by the LED. When an electrical current is applied, the electrons and holes move into the middle layer where they can combine together to produce light. But if we squeeze too many electrons in the middle layer to increase the amount of light coming out of the LED, then the electrons may collide with each other rather than combine with holes to produce light. These collisions convert the electron energy to heat in a process called Auger recombination and lower the efficiency of the LED.

A way around this problem is to make more room in the middle layer for electrons (and holes) to move around. A thicker layer spreads out the electrons over a wider space, making it easier for them to avoid each other and reduce the energy lost to their collisions. But making this middle LED layer thicker isn't as simple as it sounds.

Because LED semiconductor materials are crystals, the atoms that make them up must be arranged in specific regular distances apart from each other. That regular spacing of atoms in crystals is called the lattice parameter. When crystalline materials are grown in layers on top of one another, their lattice parameters must be similar so that the regular arrangements of atoms match where the materials are joined. Otherwise the material gets deformed to match the layer underneath it. Small deformations aren't a problem, but if the top material is grown too thick and the deformation becomes too strong then atoms become misaligned so much that they reduce the LED efficiency. The most popular materials for blue and white LEDs today are InGaN surrounded by layers of GaN. Unfortunately, the lattice parameter of InGaN does not match GaN. This makes growing thicker InGaN layers to reduce electron collisions challenging.

Williams and Kioupakis found that by including boron in this middle InGaN layer, its lattice parameter becomes much more similar to GaN, even becoming exactly the same for some concentrations of boron. In

addition, even though an entirely new element is included in the material, the wavelength of light emitted by the BInGaN material is very close to that of InGaN and can be tuned to different colors throughout the visible spectrum. This makes BInGaN suitable to be grown in thicker layers, reducing electron collisions and increasing the efficiency of the visible LEDs.

Although this material is promising to produce more efficient LEDs, it is important that it can be realized in the laboratory. Williams and Kioupakis have also shown that BInGaN could be grown on GaN using the existing growth techniques for InGaN, allowing quick testing and use of this material for LEDs. Still, the primary challenge of applying this work will be to fine tune how best to get boron incorporated into InGaN at sufficiently high amounts. But this research provides an exciting avenue for experimentalists to explore making new LEDs that are powerful, efficient, and affordable at the same time.

Acknowledgements:

This work was supported by the Designing Materials to 282 Revolutionize and Engineer our Future (DMREF) Program under Award No. 1534221, funded by the National Science Foundation. This research used resources of the National Energy Research Scientific Computing (NERSC) Center, a DOE Office of Science User Facility supported under Contract No. DE-AC02-05CH11231.

About the research:

The research was carried out by Logan Williams and Emmanouil Kioupakis at the University of Michigan.

Related publication:

[1] L. Williams and E. Kioupakis, BInGaN alloys nearly lattice-matched to GaN for high-power high-efficiency visible LEDs, *Applied Physics Letters* 111, 211107 (2017). DOI: 10.1063/1.4997601

Related conference presentation:

L. Williams and E. Kioupakis, Predictive Modeling of BInGaN Alloys Lattice Matched to GaN for Efficient High-Power Visible LEDs, MRS Fall Meeting 2017, EM04.03.02

“UV Power” Research Project to Replace Conventional UV Light Sources with LEDs

Since February 2017, a total of five research institutes and companies have been working on “UV Power”, a collaborative project funded by the German Federal Ministry of Education and Research (BMBF). The partners have made it their goal to provide high-power UV LEDs to cover a wide variety of applications. These LEDs will eventually replace conventional UV light sources, which often contain toxic mercury, in areas such as production, disinfection, the environment, life sciences and medicine. UV LEDs are also likely to open up new areas of application.

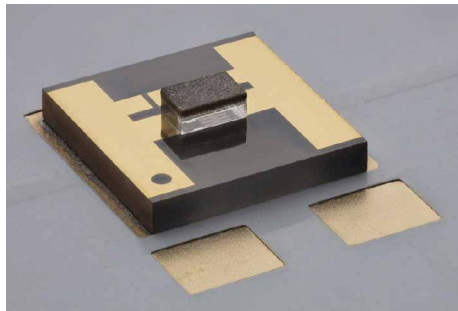

UV-LED in flip-chip geometry mounted on an AlN submount: The project, which is being coordinated by Osram Opto Semiconductors, aims to develop new technology for high-power mass-market UV LEDs

As part of “Advanced UV for Life”, a consortium of research institutes and companies which is being funded under the federal “Zwanzig20” program, Osram Opto Semiconductors is working with four partners on high-power UV LEDs for the mass market: the Ferdinand-Braun-Institut, Leibniz-Institut für Höchstfrequenztechnik (FBH), the Technical University of Berlin, LayTec AG and UVphotonics NT GmbH. Prototype LEDs and the technology for producing high-power LEDs for the UVB and UVC spectrums on the basis of the aluminum gallium nitride (AlGaIn) material system are scheduled to be presented by 2020.

The partners are therefore pooling their scientific know-how and making their highly specialized technical facilities and analysis methods available. Development of the high-power LEDs is taking place along the entire technology chain for LED production. “The various tasks have been distributed among the partners on the basis of their strengths – everything from the production of

structured sapphire substrates, epitaxy and chip processing to packaging and analytics”, said Dr. Hans-Jürgen Lugauer, Head of UV Development at Osram Opto Semiconductors. “With our presence on the international market and our expertise in industrial manufacturing we are boosting the impact of the consortium considerably,” he added.

To speed up development and make efficient use of resources, the partners are splitting their work into different wavelength ranges. In addition to coordinating the entire project, Osram Opto Semiconductors is taking on the wavelength range of 270 to 290 nm. In epitaxy, the Ferdinand-Braun-Institut is covering the adjacent wavelengths in the UVB range between 290 and 310 nm and processing the epitaxial wafers into UV chips. The Technical University of Berlin is focusing on the wavelength range of 250 to 270 nm, applying its expertise in material analysis for AlGaIn materials and AlGaIn LEDs. TU Berlin also has extensive specialized equipment for UV analysis. LayTec AG is developing tailor-made techniques for controlling the epitaxy and plasma etching systems. FBH spin-off UVphotonics NT GmbH is the interface to users. It is responsible for optimizing the chip design, for achieving high currents and for efficient cooling. The company is also handling the statistical collection and analysis of process data from the entire production chain and making this data available to the project partners for optimizing the production process. The important subjects of assembly technology and the effects of aging will be investigated by FBH, TUB and UVphotonics in further projects as part of the consortium.

The optical outputs of the new LEDs are expected to be greater than 120 mW at 300 ± 10 nm, 140 mW at 280 ± 10 nm and 80 mW at 260 ± 10 nm. The research group is also working on making significant improvements to the aging behavior of the LEDs so they can be operated longer and more economically.

For more information on Advanced UV for Life, please visit <https://www.advanced-uv.de/en/about/welcome/>

TiL 2018 Is Your Chance to Influence the Future of Lighting Design

Digitization and connectivity have revolutionized lighting design, transforming it into a multidisciplinary service, one that plays an integral part in architecture, aesthetics, behavioural sciences and technologies. Lighting designs must adopt a human centric approach. Designs for smart buildings and cities must be agile to keep up with rapidly changing user behaviours and new functionality requirements. Our mission is to bring together the most fascinating innovators, inventors and industry leaders. And that includes you! TiL 2018 will inspire and encourage attendees to build a future for lighting design that is relevant and secure, and our speaker opportunities mean you can be part of creating that future.

Bridge the Gap

It is time to close the innovation circle, to bridge the gap between technologies and design to reinvigorate how lighting designers, architects, engineers, consultants, planners and investors think, so they can realize the full potential and value of lighting design.

The effect of lighting technologies, and therefore lighting design, on everyday life has reached a crucial point; one that requires all of our input. By coming together we hope to create a future of Lighting Design that is the best possible version of itself.

Use TiL 2018 as Your Launch Pad

We want you to join us in speaking at TiL 2018. We are looking for the most inspiring, compelling and thought provoking speakers to share their thoughts on topics such as:

- SMART CITIES & BUILDINGS
- FUTURE LIGHTING DESIGN
- CREATIVITY IN LIGHT
- LIGHT RESEARCH
- LIGHT SOURCE TECHNOLOGIES
- CONNECTED LIGHTING
- APPLICATIONS & CASE STUDIES
- STANDARDS, SAFETY & EMERGENCY
- HANDS-ON DESIGN

Open Up to a Global Network

For all our speakers we offer the chance to join us for the full 3 day program in the beautiful city of Bregenz, Austria. TiL is not just a conference, it is also the perfect opportunity for you to network with 100 lighting designers from over 15 different countries. It is important to remember that sometimes you have to take a break from the "work" of your work, to sharpen your skills.

Speaker submission for TiL 2018 is now open. For details, please visit the TiL website at www.til2018.com/call. ■





TiL 2018 aims to bridge the gap between technologies and design, to reinvigorate how lighting designers, architects, engineers, consultants, planners and investors think.

Join us and explore intelligent, digital lighting design for smart buildings & cities.



Apply to be a Speaker
www.TiL2018.com/call

2nd International TiL
Bregenz | September 25–27, 2018

www.TiL2018.com



LpS 2018 Is Your Chance to Influence the Lighting Technologies of Tomorrow

Presenting a paper at conferences is the perfect opportunity with which to bolster an institution or a company reputation while simultaneously supporting and highlighting your individual field of excellence and your achievements. Not only is delivering a paper a means for gaining recognition, conferences are a way for academics, researchers and leading industry experts to enrich themselves, be introduced to new ideas, be challenged by the meeting of minds, and to enjoy themselves; all of which have a positive impact on everyone's professional and personal development.

Reach the Largest Possible Audience

Last year we saw over 1600 delegates attend LpS, coming from over 38 different countries from around the world. LpS offers you a personal platform to reach out to the very best in lighting technologies, globally. This year could be your chance to exchange experiences with international lighting experts and to expand your knowledge on current and future trends and developments.

Stand Out in the Market Place

Presenting at a conference helps assert you as a leader in your field or you can suggest presenting to a colleague. An increasing

amount of thought leaders within your organization will help expand your influence and cement your hold within the industry. Your name, company or institution, will be automatically associated with the subject you excel in, and this will allow you to raise your profile in your field of interest. You can join the list of prestigious LpS speakers, including representatives from NASA, CISCO, and HUAWEI, and even a Nobel Prize winner.

If you are a researcher at an university or research institute, and you submit a paper for LpS, you may apply for the coveted LED professional Scientific Award. Winners of this award have gone on to have great success.

Enjoy Yourself

For all our speakers we offer the chance to join us for the full 3 day program in the beautiful city of Bregenz, Austria. LpS is not just a conference, it is also the perfect opportunity for you to network and enjoy yourself with like-minded people and to experience wonderful hospitality. It is important to remember that sometimes you have to take a break from the "work" of your work, to sharpen your skills.

These are just a few reasons to submit your latest findings and to join LpS 2018. Call for papers is now open, submit your abstract today at LpS2018.com/call. ■

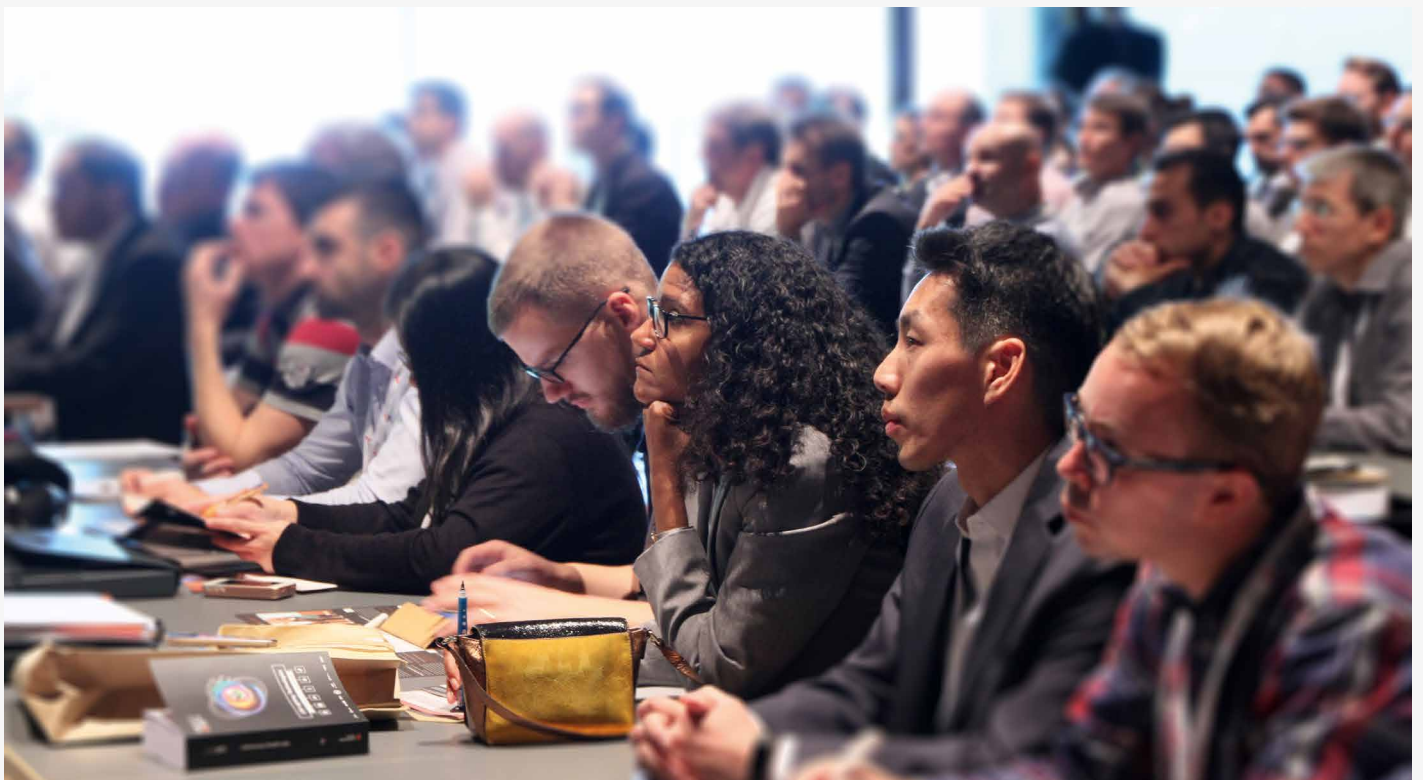

LpS 2018

LED SYMPOSIUM
professional +EXPO

LpS is ready for the future!

Are you?

Join us.

Call for papers is now open.

The leading lighting technologies event for design, testing and production of lighting systems, controls and equipment.

8th International LpS | September 25th - 27th 2018 | Bregenz | Austria

Organized by

LUGER RESEARCH
Institute for Innovation & Technology

Co-hosted with



www.lps2018.com

CIE Supports Tailored Lighting Recommendations

The International Commission on Illumination (CIE) understands the importance of adjusting lighting to optimally serve the needs of individuals and in different applications. A concerted research effort is required to deliver knowledge that can support specific lighting recommendations for specific populations and times.

Individuals differ widely in their visual capabilities and needs. However, lighting recommendations are based on results averaged across samples, usually drawn from able-bodied young adults active during daytime, and hence may not account for individuals or minority groups with specific needs. These differences can include the age, race, and health (visual and other) of the observer. Moreover, needs can vary within application contexts at different times, which current recommendations do not reflect.

Tailored lighting recommendations are needed in both interior and exterior lighting. These two application fields are covered by CIE Division 3 “Interior Environment and Lighting Design” and CIE Division 4 “Transportation and Exterior Applications”. An important development took place in October 2017, when by merging the former CIE Divisions 4 and 5, a new Division 4 has been commenced that now covers the full range of exterior applications and strengthens closer collaboration of experts in this field. However, research on tailored lighting demands close collaboration between fundamental research and application research. Fundamental research is represented by CIE Division 1 “Vision and Colour”, responsible for studying visual responses to light and establishing the related standards and also CIE Division 6 “Photobiology and Photochemistry” which addresses biological effects of light and radiation.

Elderly and Visually Impaired

In many countries, people are living to older ages, and the proportion of older people is increasing. With age, the visual system deteriorates, and this means that lighting recommendations based primarily on research with younger populations may not be suitable. Although there is good knowledge of the visual changes that occur with age, such as diminished visual acuity and increased susceptibility to disability glare, far less is known about how to adapt lighting design and recommendations to the visual needs of those with specific visual impairments. The knowledge generated under this topic would lead to benefits for segments of society that are not well served by current recommendations, including those with visual impairments.

In the past few years the CIE has published three reports which are a start to addressing these needs, primarily for interior lighting applications.

CIE reports on this topic:

- CIE 227:2017 Lighting for Older People and People with Visual Impairment in Buildings
- CIE 218:2016 Research Roadmap for Healthful Interior Lighting Applications
- CIE 196:2011 CIE Guide to Increasing Accessibility in Light and Lighting

For outdoor lighting, far less knowledge is available. One application where this might be critical is lighting for drivers, given that the outcome of inadequate vision may have serious implications. Work on this issue is underway in technical committee TC 4-54

“Road Lighting for Ageing Drivers”.

More fundamental work is occurring in TC 1-84 “Definition of Visual Field for Conspicuity” and TC 1-89 “Enhancement of Images for Colour Defective Observers”, the latter focused on a specific visual problem.

Key research questions being currently considered include:

- What are the age-related changes in non-visual photoreceptors (ipRGC) and neural responses? How does this change lighting recommendations for the elderly?
- Which ageing effects of the visual system are most detrimental to the performance of workers, drivers and pedestrians and how could or should this be taken into account in lighting design and requirements?
- How do visual impairments or disabilities affect the performance of people and how should these be taken into account in lighting design?

Understanding these issues is expected to drive technological change by providing the evidence needed for the development of suitable lighting technologies or design practices to assist these populations.

Health Conditions

Other user groups of special interest are those susceptible to migraine headache, epilepsy, and depression. The potential beneficiaries of this work are many. For example, there is some evidence that certain individuals are more susceptible to spatial and temporal patterns of light and are at risk of headache, eyestrain,

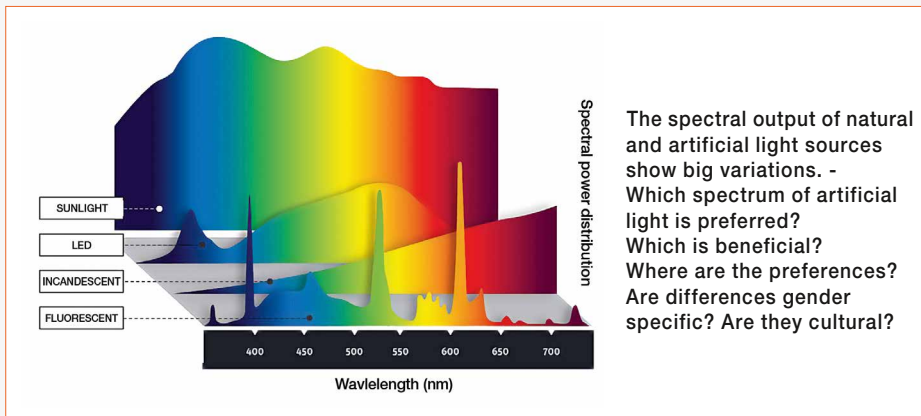

and visual disturbance as a result, but there are no specific lighting design recommendations for these individuals and no validated method for identifying those who might need this assistance. However, any recommendations from the research should also consider the impact on the wider population who might not need this assistance.

In a related vein, there is evidence that lighting recommendations could be made conditional in order to provide guidance that balances different concerns. For example, high colour fidelity may improve visual performance such that illuminance levels could be reduced. This could be of benefit to those with colour vision deficiencies, as well as offering the opportunity to reduce lighting energy use.

Genetic and Cultural Differences

Differences in visual needs associated with genetic variation are investigated within very current research projects and have been reported at the last CIE mid-term meeting in Korea. It was found out that level of melanin in the human eye is responsible for different visual perception. This may explain differences in research results between Asian populations and others, and might also account for the observed differences in lighting practice in different cultures. Other research projects are aimed at study of facial skin tone preferences in relation to light source spectrum. However, results of such investigations are yet isolated and require broader confirmation what is indispensable without support in form of further research activities.

Season and Time of Day

Visual needs differ not only between individuals but they vary also with season and time of day. Ergonomic lighting supports working enthusiasm by conscious control of hormonal processes through spectral distribution of light, its timing and intensity. Good lighting prevents fatigue, which can lead to errors. Once the work is done, lighting should help to create a relaxing atmosphere for regeneration. This has often to be satisfied by the same lighting installation.

Interaction of Different User Groups

Meeting the varying needs of different users in the same space is another point of interest. Some of the applications where this problem is particularly significant: classrooms (teacher vs. children), retail shops (shopping assistant vs. customers), sport facilities (athletes vs. referees, fans and camera systems), roads (drivers, pedestrians, inhabitants).

Applications

The need for recommendations to support both visual and non-visual effects of light on humans is obvious in lighting of interior workplaces, particularly those occupied on a 24-hour basis. Outdoor workplaces have been studied less, but the challenge is no different, especially at night. Night workplaces face challenges to keep the workers active and alert - night shifts are known for loss of attention, fatigue and sleepiness. Increasing light levels and blue content in the spectrum may help the workers, however, obtrusive light may harm inhabitants living nearby working sites, disturbing their sleep. Intrusion of stray

light in the night-time environment must be limited to protect the local ecosystem. The question is how to balance these contradictory requirements and how to optimize the lighting system with respect to the needs of different people, the ecology, and with the best energy performance.

The situation in road lighting and public lighting of exterior communications in general is very similar. For drivers it is important to support visual performance and to prevent fatigue. However, pedestrians are affected by the same lighting but they may require more relaxing effects so that they can sleep easily shortly after they finish their walk outdoors.

Home lighting itself is an unknown territory. There are only few scientific papers on this subject available. People coming home from workplace, shopping or having spent some time outdoors by sporting or cultural activities require different quality of light in evening and early morning hours than outside. There are few studies on lighting quality preferences and a strong support for research must be devoted for that area. Feedback from questionnaire-based investigations showed that ordinary people are unable to set the lighting according to their real needs and preferences and recommendations would be much appreciated here.

New Technologies for Demanding Lighting Tasks

With tailored lighting a new era in lighting is emerging. It is hard to imagine that tailored lighting can be of a static type and only determined for a single group of users, ignoring others who share the same space. Happily, technology exists today to enable the tailored control we foresee: the possibility to compose a light spectrum and to change it easily, almost infinite dimming options, and dimming reacting immediately. Nevertheless to realize this vision we must first understand what people need, both physiologically and psychologically, and set proper criteria for lighting parameters by a holistic approach. CIE calls on the lighting community to help to generate the knowledge we need to make the best use of the tremendous new capabilities of lighting systems. ■

Tech-Talks BREGENZ - Julia Frohleiks, Researcher, University of Duisburg-Essen



Julia Frohleiks

Julia Frohleiks, M.Sc., is a member of the Junior Research Group "Solid State Lighting", located at the Nano Energy Technical Center at the University of Duisburg-Essen. She studied NanoEngineering and received her bachelor degree in 2011 and her master's degree in 2014 at the University of Duisburg-Essen, with specialization in the field of Nanoelectronics/Nanooptoelectronics.

Currently, she is developing luminescent devices combining colloidal quantum dots with light-emitting electrochemical cells, which is the topic of her PhD.

In his commentary on technical progress and innovation, Dr. Sejkora said: “In the early stage, in the first phase of its life cycle, technology is mainly driven by fundamental research.” He went on to say that we can never predict how a technology will develop. Researchers from the University of Duisburg-Essen, working in the Nano Energy Technical Center (NETZ), worked on this type of fundamental technology and their submission received the LpS 2017 Scientific Award. Ms. Julia Frohleiks, a Ph.D. student, was a major contributor to this research in the group led by Dr. Ekaterina Nannen and accepted the award in Dr. Nannen’s name. In the following interview she gives some background information and discloses future research possibilities.

LED professional: Thank you very much for agreeing to this interview. Dr. Ekaterina Nannen was named as the head of the group that worked on the paper that won the LpS Scientific Award 2017 and you are representing her here, in her absence.

Julia Frohleiks: Yes, that’s correct.

LED professional: Could you tell us a bit about your workgroup and the environment you work in? Who is Ekaterina Nannen and who is Julia Frohleiks?

Julia Frohleiks: Our workgroup is located at the University of Duisburg-Essen. A cooperation between the University of Duisburg-Essen and Osram on novel concepts for solid state lighting was initiated by Professor Bacher, Department of Electrical Engineering, and in 2012, Dr. Ekaterina Nannen was selected to head the group. It’s a junior research group located at the Nano Energy Technical Center (NETZ), which is devoted to nanomaterials and technologies for energy applications. NETZ hosts a lot of different groups from different

fields including mechanical engineers and chemists as well as physicists and electrical engineers, and everyone is working on Nano-materials within their fields.

In the beginning, our group had two PhD students - one doing light-emitting electrochemical cells (LEC’s) with nanomaterials for increased performance, the other one working on quantum dot LEDs. I joined the group about one year later and develop luminescent device combining quantum dots with LEC’s.

LED professional: You are working on your PhD, is that right?

Julia Frohleiks: Yes, all three of us are working towards our PhD’s and Ekaterina Nannen is our group leader. I studied NanoEngineering at the University of Duisburg-Essen. The university has a new study program on NanoEngineering with specializations in Nanoprocstechnology and in Nanoelectronics/Nanooptoelectronics. I focused on the latter and received my master degree in this field in 2014.

LED professional: Do the groups inside of NETZ collaborate?

Julia Frohleiks: Yes, that’s the central idea. The NETZ is part of the Center for Nanointegration Duisburg-Essen (CENIDE). So collaborations between the single groups within the university and especially within the NETZ are strongly supported. In-house, we also have the Interdisciplinary Center for Analytics on the Nanoscale (ICAN), which offers its service to every working group and even external scientists. They have, for example, high-end transmission electron microscopy and other specialized tools and we can go there and give them samples for characterization.

LED professional: Is NETZ the biggest center or research institute for nanomaterial in Germany?

Julia Frohleiks: It is the only one focusing on the combination of “nano” and “energy” - this is unique in Germany. It was built in 2012, so it’s quite new. Nanotechnologies are, in general, quite timely and our university has an outstanding experience on



Nanomaterials for the past 15 or 20 years. Nanosciences are even one of the four key research profile areas of our university.

LED professional: Maybe you could tell us a little about Ekaterina Nannen.

Julia Frohleiks: Yes, of course. She was born in Russia and came to Germany when she was 15 years old. She finished university in Duisburg-Essen where she studied electrical engineering and did her PhD in electrical engineering. Afterwards, she headed the junior research group in collaboration with OSRAM. The focus of the group is large area light emitters, solution-based, for low cost applications later on. Here we develop, on the one hand LEC's, and on the other hand push the implementation of quantum dots in lighting applications, paying particular attention to environmentally friendly materials.

LED professional: I'd like to go on now to the research program itself. LEC is something that isn't very well known. Some people even think that LEC is a typo and it should say LED!

So could you give us a bit of background including the physics and state-of-the-art of LEC?

Julia Frohleiks: Sure. LEC is a large-area emitting device so you can compare it to organic LEDs (OLEDs). It has comparable active light emitting species so it's also organic and can either be a polymer or a transition metal complex. But the difference to OLEDs is that ionic species are integrated within the active layer of the LEC. These species start moving when voltage is applied to the device. Due to the accumulation of the ionic species at the electrodes, electrical double layers form, that facilitate the charge injection. So all the additional supporting layers that are typically needed in organic LEDs can be omitted and LEC's can be made, in the easiest case, out of one layer. The concept is really attractive, for example, for printing fabrication and flexible devices.

LED professional: When I hear about electrochemistry I always think in the direction of anodizing aluminum or batteries, or something

like that. So I have a kind of solution - something fluid. But when you talk about LEC it sounds a little different.

Julia Frohleiks: Yes. The name comes from a second effect that is important in the LEC. When you continue applying a voltage to the LEC, the ions separate and form p- and n-doped regions close to the electrodes by interaction with the lighting molecule. And this process is called electro-chemical doping. This doping is the reason why you have the name - electro-chemical cell.

LED professional: But it doesn't work in the fluid phase, does it?

Julia Frohleiks: In our case, the final layers within the device can be called solid. We prepare the solutions in the fluid phase but then we spin coat and let them dry - a similar process as for QD-LEDs and solution-based OLEDs.

LED professional: What is the difference between the LEC and the OLED?

Thrilled with having won the LpS Scientific Award, Julia Frohleiks was happy to be interviewed by Dr. Sejkora and Arno Grabher-Meyer for the Tech-Talks Bregenz



Julia Frohleiks: The main differences are the incorporation of ionic species and the resulting easy fabrication process. You can do it solution-based, in one layer and it's not too sensitive to the air. OLEDs typically degrade very fast when they come in contact with water and air. Although the light emitting species are quite similar, in the case of LECs we can omit the injection and transport layers and even use air-stable electrodes for the electrical contact, like, for example, aluminum.

LED professional: About the quantum dots: Can you give us some background information about the physics of the quantum dots you are using?

Julia Frohleiks: When we talk about quantum dots, we mean colloidal semiconducting nanocrystals. These tiny semiconductor crystals are typically less than ten nanometers in size which leads to quantum confinement effects: the band gap increases and can be tuned by the nanoparticle size. So you can create robust, semiconducting emitters that are tunable in emission color.

LED professional: And are these quantum dots in the LEC layer or is there a special layer?

Julia Frohleiks: In the hybrid device that we introduced at LED professional, it's a special layer. We prepared them in dispersion, whereby they were stabilized by organic ligands. Then we spin-coated them on top of the active LEC layer.

LED professional: What we heard in your lecture is that the current efficacy of the hybrid LEC is not very high and you improved it by using the QDs. In the lighting domain we already have the OLED and the LED with really high efficacy and you should follow. How do you see the future?

Julia Frohleiks: Our goal is not to compete with the LEDs - it's already

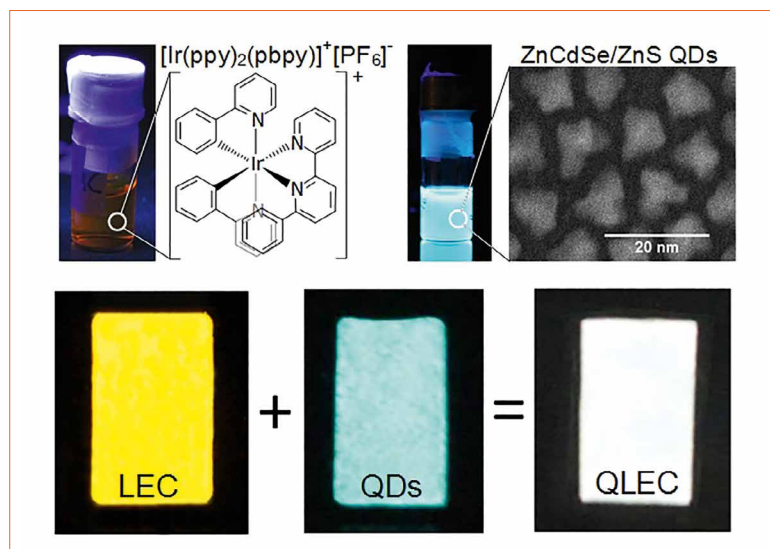

Principle structure of a white QLEC device

hard for OLEDs to reach their benchmarks. I think there are just different types of applications waiting for the LEC family. You can't light up a stadium with LECs - but you might realize cheap and flexible lighting elements for consumer electronics, for example. I don't think it will be necessary to become as efficient as the LED and OLED but still we will need to have better performance compared to now.

Efficiency is related to the balance of holes and electrons in the device. What we already did is to improve this balance - in our case, push the electrons because standard devices are usually hole dominated. So I think we have to go more in that direction. And you also have to think about the behavior of these LECs with time: because of the ion movement, the device characteristics are quite dynamic and this has to be stabilized for reliable application. This is the big challenge for the LECs, I think.

LED professional: Do you already have something in mind, when you say that you need to think about different applications? And what would be the advantage of using an LEC with quantum dots?

Julia Frohleiks: I think the LEC is really interesting for low cost / disposable applications: Maybe for light-emitting stickers or smart tags. Because one can print them using every kind of printing technology

and they are particularly tolerant against thickness variations, for example. They can be prepared in ambient conditions so you can basically use printers, which means they are quite cheap to produce. You can think about doing stickers for milk bottles that change color when the expiry date has been passed. The color might change from green to red and everyone can see that it shouldn't be sold anymore. Maybe an LEC in combination with quantum dots on a sticker would be a good application - so it's not really lighting up a room.

LED professional: Would you need an electrical voltage source on each bottle or pack of milk? A battery or a solar cell?

Julia Frohleiks: Yes, or an RFID transponder or something similar. It's a vision I heard about.

LED professional: This leads me to my next question. Are you driving the LEC with low voltage?

Julia Frohleiks: There are different ways to drive the LECs. The best performance is typically reached when the LEC is driven with pulsed current for better ion movement stabilization. And what I did with the hybrid device - I drove it with constant voltage for better understanding of the working mechanism behind.

Voltage versus luminance comparison between LEC, QLED and QLEC. The inset shows the prepared QLED, QLEC and LEC devices under UV illumination with increasing voltage from left to right

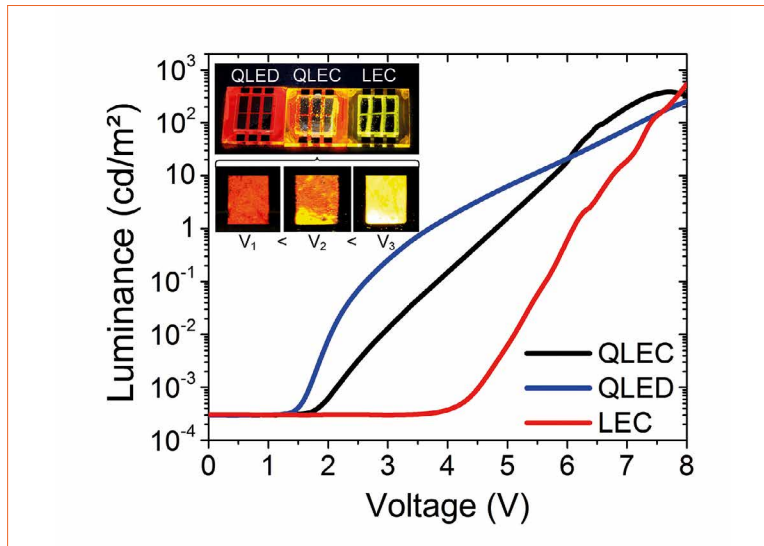

LED professional: In one of the images you showed during your talk was this hybrid combination. Is it more the quantum dots that contribute to illumination at a lower voltage?

Julia Frohleiks: Yes, that's right. And the LEC becomes dominant at higher voltages.

LED professional: So, in general, the brightness of the LEC is still driven by the voltage, correct?

Julia Frohleiks: Actually it's controlled by the amount of electrical charges (current) flowing through the device and recombining radiatively. This is, at the same time, coupled with the electrical field because the electrical field is forcing the ions to move.

LED professional: But can you control brightness with a hybrid system?

Julia Frohleiks: I think you could also control the brightness. At first you have to increase the quantum dot efficiency because when I did it, I had quantum dots that weren't perfect. But now they are much brighter. So if such devices are prepared again with improved quantum dots, I believe you could increase the brightness of the whole device. And then ideal driving conditions for efficient excitation of both light emitting species have to be found.

LED professional: In which frequency domain do you work?

Julia Frohleiks: The LECs are normally pulsed with one/a few kilohertz. But it depends on the thickness of the layer and the amount of ions you have inside. One always has to find the optimal driving conditions for the device. It depends a lot on details.

LED professional: Can you give us some ideas on the parameters for driving the light sources?

Julia Frohleiks: At the moment they are only prototypes so they are slightly below 10 square millimeters. The typical current for getting really bright emission is about some milliamps in the device. The light-emitting devices based solely on quantum dots as light emitters in our group have an external quantum efficiency of a few percent. In literature, it is shown that this also depends on the device architecture, with a lab record up to 22% external quantum efficiency- but for lower brightness. LECs highly depend on the driving conditions. We reach about 4 to 6 % for the best yellow and green ones. The white one, I think, is about 0.2% external quantum efficiency, but the blue quantum dots aren't as good as the red ones.

LED professional: Yesterday during your talk you mentioned that you'd like to take the direction of focusing

on quantum dots that are not activated by light, to convert light but that are activated by current.

Julia Frohleiks: Actually in the hybrid device they are directly activated. Our vision for the future is to replace the organic emitter completely. So we would keep the concept of the LEC where there are mobile ions that are moving and facilitating the charge injection and the transport. We move away from the organic emitter and take quantum dots as the only light-emitting species because they are more robust and then combine this in an LEC architecture resulting in a novel "QLEC" device.

LED professional: What would that look like? In terms of color it's clear - you control it by the size of the quantum dots. But in terms of white light - would the sizes of the quantum dots be mixed or would there be single layers?

Julia Frohleiks: Actually, that is what I'll be working on when I get back. I think we will definitely work with different colors. As known from the OLED industry, both mixed and stacked device architectures have their advantages. We have already shown that it is possible to fabricate QLECs with one color so we did it with copper indium sulfide based quantum dots and with an ionic liquid all mixed together within an organic matrix for charge transport. The next step is to go for more colors, paying particular attention to cadmium free material systems: their luminance isn't yet as good as of the "traditional" cadmium based QDs, but the environmental safety plays a more important role, especially in targeted applications.

LED professional: Do you and your institute have a roadmap? Or is there a roadmap of these quantum dots within the industry? In all areas, whether OLEDs or LEDs there was a roadmap of expectations to reach a certain efficacy level quite early on.

Julia Frohleiks: I know that there has been a lot done in the research

field but I don't know if there are roadmaps for the industry yet. I do know that there are three main fields. One is the field of converters as an alternative to phosphors. Another one is displays - because of the small full width half maximum of the quantum dots. I believe that they already have a roadmap because Samsung is really focused on displays and TVs. They already started selling the TVs with quantum dots. But in the field of lighting, the application of QDs remains yet exotic - at least currently.

LED professional: I would like to know a bit more about the physics behind LEC plus quantum dots. Is it a unique idea to combine them and are there other research groups working on this? And how did the idea of combining them come up?

Julia Frohleiks: The idea to combine the iTMC based LEC with quantum dots is unique. No question. One other group showed the combination of a polymer based LEC with quantum dots two years ago but they mixed them into one layer. We did it layer by layer and forced each component to become active within one and the same device, so it's a bit different.

LED professional: When you say they mixed it - do the quantum dots in the mixture work as an emitter or as a converter?

Julia Frohleiks: They did not discuss that issue deeply, to my mind the operation as a (down) converter is very probable in that case.

LED professional: How did the idea come about? If you're in the field - is it a big change of mind or is it a logical consequence?

Julia Frohleiks: Actually, our group leader - Ekaterina Nannen - has an endless number of ideas and there are many, many more things that she wants to try. After her PhD she wanted to work with quantum dots because she had already done light emitting nanocrystals based on zinc oxide and she knew that the

efficiency is always limited but that quantum dots have the potential to have good efficiency. And then she learned about the LECs from Osram - so, it was pretty straightforward for her to combine these two fields.

LED professional: But now she wants to discard the LEC and go back to the quantum dots.

Julia Frohleiks: Yes, but keep the idea of the working principal of the LEC.

LED professional: How far will you go with your research? I think what you are doing here is basic research, is that right?

Julia Frohleiks: Yes, that's correct.

LED professional: So going on to applied research - I don't think it will be done in your group - are there other groups interested in going on in this area?

Julia Frohleiks: Not that I know of. We are at a point where we could go forward and we are currently checking some ideas at the moment. We are also open for collaborations with someone who is interested in the scale up of the technology or long-term testing.

LED professional: If I understood the technology correctly, you said that currently your samples are very small but it's easier to scale up your samples than it would be to scale up an OLED because in a simple version you have one layer or maybe a couple of layers but a high quality OLED has quite a lot of layers.

Julia Frohleiks: Yes, that's correct. That is one of the advantages of the LEC. And the layer is not sensitive to the thickness. So it's not 3 nm or 4 nm like it sometimes is for the OLED but can be as thick as 50 to 400 nanometers. And thickness variations on tens of nm scale don't really matter much. I think it would be easy to scale it up.

LED professional: You said that you could do it in almost any environment - so it's almost like adapted equipment.

Julia Frohleiks: Yes. And we do it in a normal lab - so we don't have a clean room or anything. You just have to be careful when you drive them because during operation they can degrade. So ideally you have to encapsulate them afterwards. You can process the whole device and then, for example, pour glass epoxy on top of them and they're fine.

LED professional: I know from speaking to you before that one of the issues you have is funding. What could you offer someone if they were interested in funding you?

Julia Frohleiks: Funding is always hard to get. It's especially hard to get funding for quantum dots in Europe at the moment because the focus in Europe is not as high as it is in the U.S. or Asia. This makes it very hard for us to compete.

LED professional: Is there a reason why quantum dots are getting so much more attention in Asia and the U.S.?

Julia Frohleiks: I think interest is growing in Europe. In fact I believe there was another lecture here at LpS concerning quantum dots. I think the industry is becoming more and more interested in it and I hope that it's not too late for us to catch up to especially Asia where a lot of the industry is active in the field. And as interest grows in Europe, I hope funding will also grow.

We are very grateful for the Scientific Award - it will help us to become more well known in the industry and possibly help us to get more funding.

LED professional: One of the ideas behind the Scientific Award is to help research groups, especially young scientists, that are involved in topics that don't comply with what everyone else is doing. We want to reward them for all the work they do. So we hope that this will help to turn the focus more on QDs in Europe.

Julia Frohleiks: Yes, this will really help us. Thank you. ■

Optimization of Freeform Optics Using T-Splines in LED Illumination Design

Freeform optics is the game changer in the illumination industry in terms of its ability to redirect the light into the target area. Non-Uniform Rational B-splines, commonly known as NURBS are widely used to represent freeform curves and surfaces. There are certain optical systems where local modification of the surface is necessary during the design or optimization phase. In such cases, NURBS cannot offer such transformations. But a new mathematical representation called T-splines make this feasible. Though its potentiality is well described, this has not been implemented in any optimization routine so far. Annie Shalom Isaac, Jiayi Long and Cornelius Neumann from the Karlsruhe Institute of Technology demonstrate the advantage of the local refinement ability of T-splines by implementing it in the optimization routine and the results are evaluated. Results show that T-splines provide more uniform and homogenous light distribution as compared to NURBS at a faster convergence rate. This makes optical design or optimization using T-splines an intuitive approach for future freeform design tasks.

The design of free-form optics relies heavily on one of the methods: tailoring based on point source assumption [3], SMS design [4] and source target maps based on equal flux grids [5] to create an initial optical surface. As these mathematical methods are not guaranteed to provide accurate results for extended LED sources and as well do not provide generalized solutions, the optical designer still relies on any optimization tool to improve the results. The improvement of speed in raytracing algorithms as well as sophisticated intelligent optimization algorithms make an optimization approach more widely usable. But the drawback of optimization in freeform surfaces is mainly because of its complicated mathematical representation and the presence of many parameters. These parameters

are not directly related to the optical performance hence making the optimization a long process to meet the needed lighting requirements.

Wendel et.al proposed a method called optimization using freeform deformation (OFFD) to overcome this difficulty by placing the optical surface in a grid and deform the enclosed lattice rather than acting directly on them [1]. This method uses NURBS to represent the optical surface and their results show that with fewer optimization variables, they could attain global deformation very well, and this makes manufacturing easier. But there are certain cases which require a sharp gradient in the light distribution or a path of the light ray has to be changed significantly. In such cases, a slight local deformation brings significant improvement.

But with the current OFFD, it is not possible because of the underlying surface representation. An alternate surface representation called T-splines could overcome this drawback [2]. Bailey et.al has shown the potentiality of T-splines and its application in optical surfaces [6]. But this has neither been applied in any optimization routine so far nor its optical performance analyzed and compared against NURBS.

So this work takes this problem into account and provides an alternate way to solve this problem. Section 2 covers the OFFD technique. The mathematical surface representation of optical surfaces is covered in section 3. The implementation results of T-splines and comparison results are shown in section 4 followed by the conclusion in Section 5.

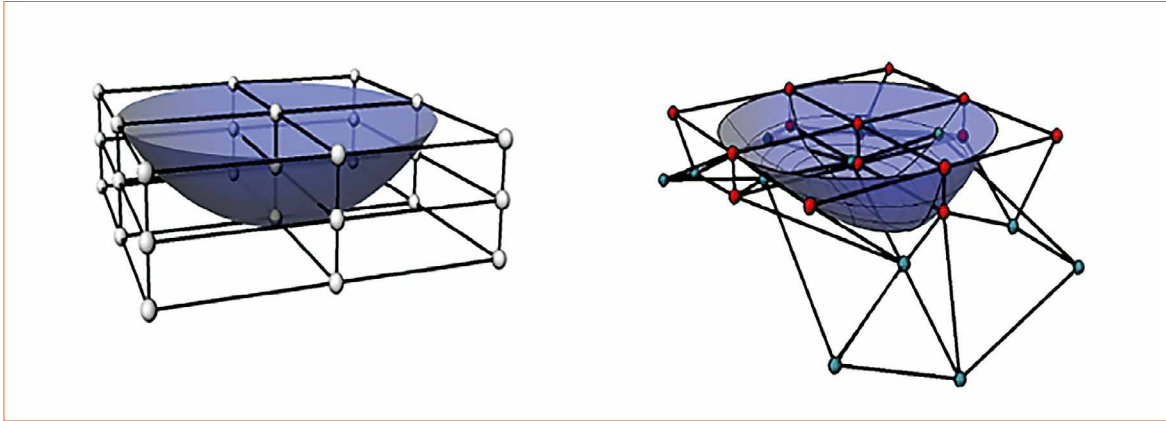

Figure 1: A 3x3 OFFD grid enclosing and optical surface before (left) and after (right) deformation

Optimization Using OFFD

OFFD methods employ freeform deformation (FFD) technique proposed by Sederberg [7] coupled with an optimization routine. The relationship between the grid and the optical surface is well established using the FFD algorithms [7]. Figure 1 shows the grid with an optical surface before and after deformations. For conciseness, only an overview of the OFFD method is explained.

The algorithm begins by selecting an input surface whose optical performance has to be improved, which is usually far from the target. By this method, the optical surface is enclosed inside the grid containing 27 grid control points and the user could select any combination out of them. This is provided as variables to the optimization algorithm. The optimization algorithm has a wide search space for the selected combination of grid points and provides shifts along the three dimensions to the enclosed grid. As the enclosed grid undergoes a change, it changes the optical surface inside too. The deformed surface is then evaluated photometric and the optimization algorithms take decisions about the shift of its optimization variables based on this result. This algorithm continues again and again until the target lighting requirements are met. The workflow is explained using the flowchart in figure 2.

The most important step in this routine is the definition of Figure of Merit for the deformed optical

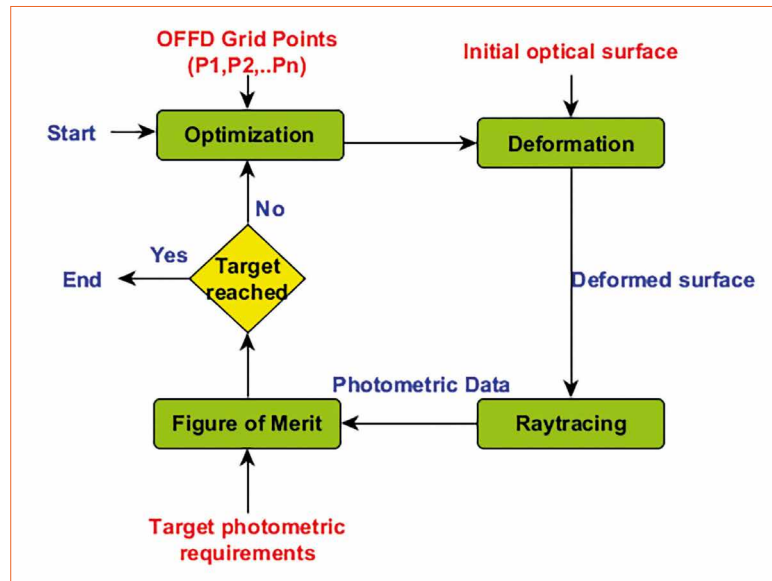

Figure 2: Workflow of the optimization of freeform deformation (OFFD)

surface as the entire optimization is based on this single value referred as Q . In this paper, we use two different merit functions.

Deviation merit function Q_{dev} which corresponds the deviation of the current simulated distribution and the desired distribution and is expressed as

$$Q_{dev} = \int_G (E_{ideal}(x) - E(x))^2 dx \quad (1)$$

G is the area that one is interested in, $E_{ideal}(x)$ is the desired illuminance distribution target and $E(x)$ is the current light distribution.

Flux based merit function Q_{flux} corresponds to maximizing the flux in the required target area which is quantified as ratio of flux in the target (Φ_t) and available flux collected by optics Φ_c .

$$Q_{flux} = \frac{\Phi_t}{\Phi_c} \times 100\% \quad (2)$$

Mathematical Representation of Optical Surfaces

NURBS

NURBS techniques are so mature that they are used in computer-aided graphics systems as well as ray tracers. Due to its flexibility, the surfaces can be easily manipulated or modified by changing the control points or its weights during the optimization routine.

NURBS surface is the parametric tensor product surface and is defined as:

$$s(u,v) = \frac{\sum_{i=0}^n \sum_{j=0}^m W_{ij} P_{ij} N_j^p(u) N_i^q(v)}{\sum_{i=0}^n \sum_{j=0}^m W_{ij} N_j^p(u) N_i^q(v)} \quad (3)$$

where P_{ij} is $(n+1) \times (m+1)$ rectangular array of control points, $w_{i,j}$ are the weights, $N_{ip}(u)$ and $N_{jq}(v)$ are basis functions of degree p and q in u and v directions, respectively associated with the knot vectors.

Figure 3:

An example showing the initial 5x5 NURBS patch (left), how the modification causes addition of control points along rows and columns when done with NURBS (middle) and in T-splines (right)

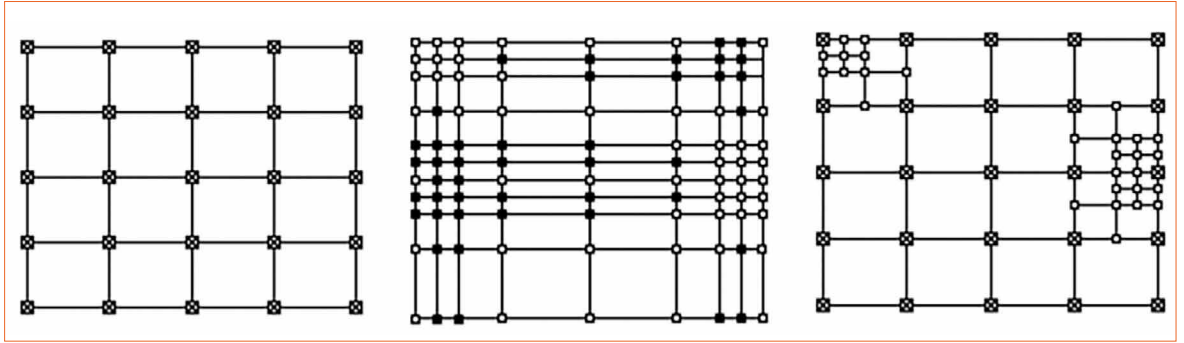
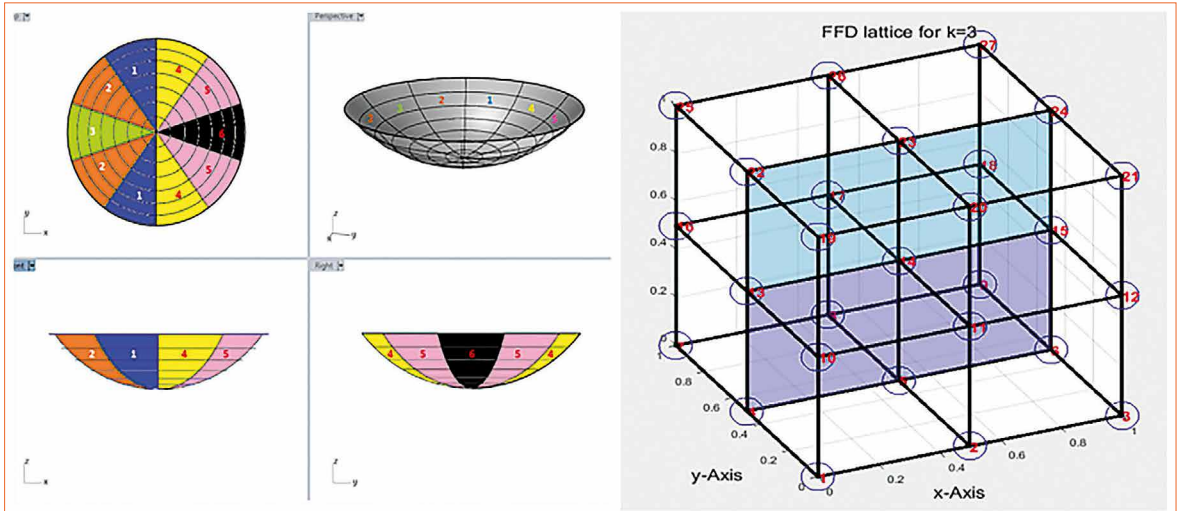

Figure 4:

Initial optical surfaces segmented into 6 sections (left) and the OFFD grid with numbered control vertices (right) ready for local deformation



$$\vec{U} = [u_0, u_1, \dots, u_r]$$

$$\vec{V} = [v_0, v_1, \dots, v_s]$$
(4)

where $r=p+n+1$ and $s=m+q+1$ hold. When a control point has to be added in NURBS, it is done using the knot insertion method. Addition of a single knot requires adding an entire column or row of control points. Knot removal is also not possible with NURBS without a change in the shape of the geometry. This local refinement is mainly limited in NURBS because of its tensor product construction as shown in EQ 3. As seen in figure 3, the NURBS surface is repeated horizontally column by column and vertically row by row. In order to satisfy this balance, if one adds a new control point, the entire column or row of control points gets simultaneously added.

T-splines

The drawbacks imposed by NURBS can be solved by an alternate mathematical representation of the freeform surfaces called as

T-splines. T-splines generalizes B-splines to assign particular row and column parameters to the specific control points by adding T-junction to B-splines which is seen relevant in figure 3. This makes T-splines a more advanced technique in local deformation without adding unwanted control points. A T-spline is a tensor product B-spline which is point based rather than grid based. The control grid is called T-mesh and definition of a T-spline surface is given by

$$S(u,v) = \frac{\sum_{i=0}^n P_i W_i N_i(u,v)}{\sum_{i=0}^n W_i N_i(u,v)}$$
(5)

where P_i are control points. $N_i(u,v)$ are basis functions, given by

$$N_i(u,v) = N_{u_i}(u) \cdot N_{v_i}(v)$$
(6)

The basic functions $N_{u_i}(u)$ and $N_{v_i}(v)$ are respectively associated with knot vectors

$$U_i = [u_{i0}, u_{i1}, u_{i2}, u_{i3}, \dots, u_{in}]$$

$$V_i = [v_{i0}, v_{i1}, v_{i2}, v_{i3}, \dots, v_{in}]$$
(7)

When one inserts a new control point or a knot, the interval between the other control points has to be refined without any change in its shape. This is done as the refinement of two univariate basis functions $N_{u_i}(u)$ and $N_{v_i}(v)$ separately by fulfilling EQ 6. This property of local refinement without increase in the number of control points as well no change in the shape of the geometry makes T-splines naturally a good choice to implement in the OFFD and attain local deformation.

Application of T-Splines in OFFD

The last section covered the theoretical background of T-splines and advantages of using it in the local deformation. This section presents the application of T-splines in the optimization routine of the freeform deformation system explained briefly in section 2. For our example, we used the same optical design task of designing a street light lens used in [1]. Cree XPG2 LED with 100 lumens is used as a light source and the initial surface before optimization

is as shown in figure 4. To evaluate the photometric performance, the merit functions expressed in equations 1 and 2 are applied.

To begin the T-spline implementation in OFFD, one has to add more control points in the needed regions and the shape of surface stays unchanged. More local deformation is achieved in the regions of the area where more and denser control points gather. A study was then conducted to find which part of the lens is influenced more by the deformation process and if the sensitive local deformation on this part leads to a better result.

The whole optical surface is separated into six sections, as shown in figure 4. This step is based on an intuitive assumption. The symmetry in the y-direction is due to the fact that the target street and the lamp stay in the middle of y-direction (Figure 5). For a straightforward comparison, the grid points [1, 3, 13 15] are chosen. More control points are added in each segment from 1 to 6. In the end, six new optical surfaces are generated. The only difference between these generated new T-spline surfaces and the initial one is the difference in the number of control points. The shape of the optics maintains the same without any variation as expected.

These optical surfaces are taken as initial surfaces one after the other for the OFFD and are evaluated using both the described merit functions. The preliminary results showed that more impact on the light distribution is seen when more control points are added to the segment 5. So this optical surface with more control points at segment 5 and less at the remaining sections is taken as an initial system for optimization and for comparison against NURBS. This result is then compared with the NURBS-based OFFD and the results are discussed in the coming section.

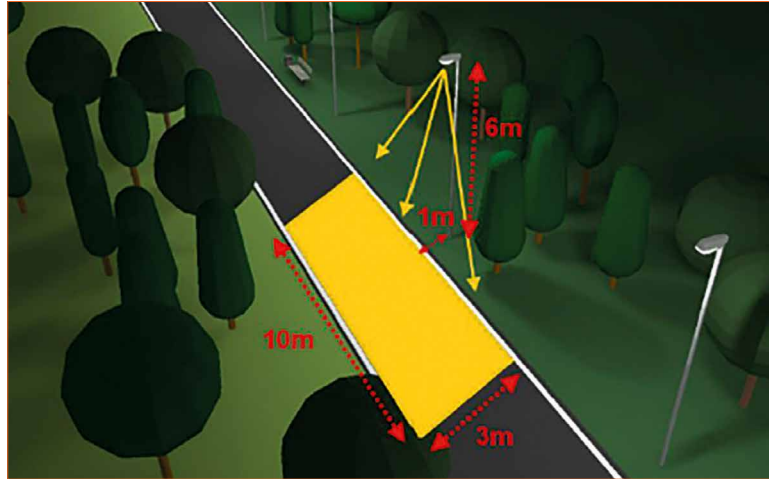

Figure 5: Schematic view of the street lighting setup with 10 m pole spacing, 6 m pole height, 1 m distance away from the road. The yellow rectangle shows the area to be illuminated [1]

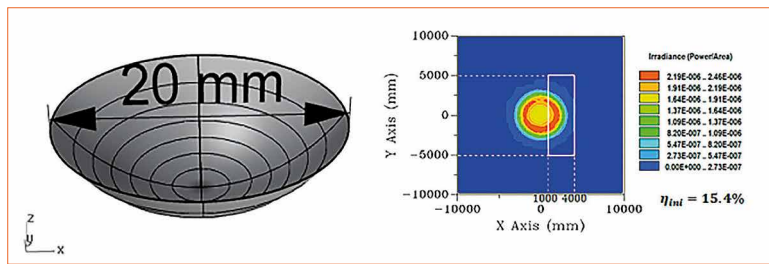

Figure 6: Illuminance distribution of the target street area (white rectangular frame) for the initial surface shown on the left

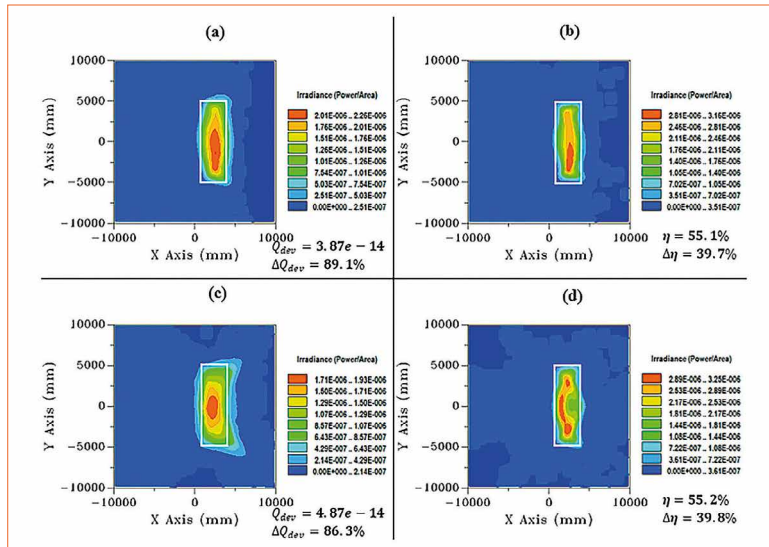

Figure 7: Illuminance distribution of the streetlight lens with more control points on the fifth section (a) using T-splines using deviation merit function (b) flux based merit function (c) NURBS using deviation based and (d) flux based merit functions

Performance of the initial system

The optical performance of the initial surface is shown in figure 6 with only 15% of total flux inside the target and the shape of the distribution is far away from the needed rectangular distribution which is marked as white.

Comparison between NURBS and T-splines

The two important photometric measures for comparing NURBS and T-splines used in analyzing the street lighting lens are total luminous

flux in the target and uniform illumination distributed well across the target. NURBS and T-splines perform at the same level for total luminous flux in the target which is found to be as 55% as illustrated in figure 7b and 7d yielding 40% improvement ($\Delta\eta$). But T-splines outperform in shaping the target distribution as required which is validated in the simulation results in figure 7a. The illuminance distribution using T-splines is more uniformly distributed than those with NURBS as shown in figure 7b. The deformed optical surface using NURBS and T-splines is shown

Figure 8: Deformed optical surface using OFFD NURBS based (left), T-splines based (middle) and the false color representation of the change in shape between NURBS and T-splines (right)

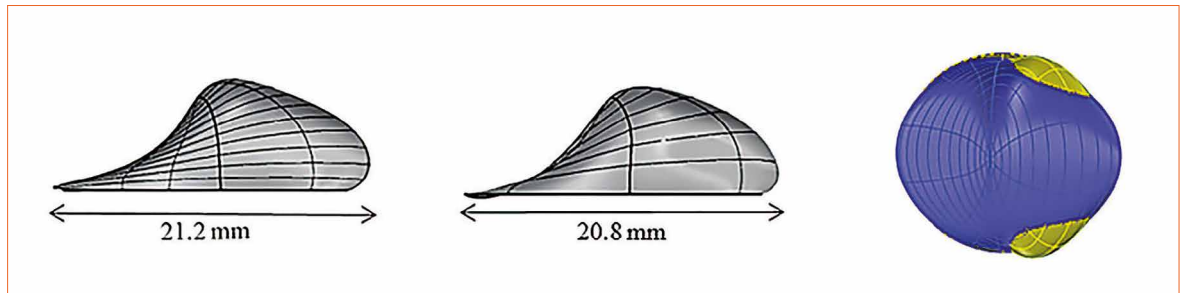

in figure 8. The slight difference is seen in the T-splines near the edges which is marked as segment 5 in figure 4. This is the segment where more control points have been added prior to deformation and performed better compared to others.

If the same results need to be attained using NURBS, the control points in the grid are more sensitive to the user's choice. When accurately chosen, one could attain these results but at the expense of the optimization's runtime which is so long - almost twice the time needed using T-splines. The most advantage in using T-splines is that when the user knows the section of the optical surface to be locally deformed he can be least bothered about the selection of the control points in the grid.

Conclusion

This work highlighted the use of T-splines for obtaining a local deformation of the optical surfaces by implementing it in the optimization routine for the first time. The results show that with T-splines one could attain more uniform light distribution as against NURBS. The sensitivity of the FFD grid points is reduced when T-splines is used. This is very important for intelligent optimization systems. As T-splines is a more advanced surface representation, it is still not yet mature. The CAD techniques and ray tracers have not grown to an extent to import and work directly with the T-splines file format. So at the time of this paper, one needs to still rely on back and forth conversion of T-splines to NURBS to perform raytracing. Another limiting factor, but not huge, is that the control points have to be

added more precisely where it is needed. In future, if intelligent optimization systems could be able to predict the segments of the optical surface automatically, then the machine could add them completely and carry optimization routine. ■

References:

- [1] Wendel, Simon, Julian, Kurz and Cornelius Neumann. "Optimizing non imaging freeform optics using freeform deformation". Proc. Of SPIE, Vol.8558.2012
- [2] Scott, M.A., et al. "Local refinement of analysis-suitable T-splines". Computer Methods in Applied Mechanics and Engineering 213 (2012): 206-222
- [3] Ries, H. and Muschaweck, J. "Tailored freeform optical surfaces." JOSA A 19.3 (2002): 590-595.
- [4] Beni, Pablo, et al. "Simultaneous multiple surface optical design method in three dimensions." Optical Engineering 43.7 (2004): 1489-1502.
- [5] Fournier, Florian R., William J. Cassarly and Jannick P. Roland. "Fast freeform reflector generation using source-target maps." Optics Express 18.5 (2010): 5295-5304
- [6] Bailey, Edward and Sebastien Carayon. "Beyond NURBS: enhancement of local refinement through T-splines." Optical Engineering + Applications. International Society for optics and photonics, 2007
- [7] Sederberg, Thomas and Scott R. Parry. "Freeform deformation of solid geometric models." ACM SIGGRAPH computer graphics 20.4 (1986): 151-160

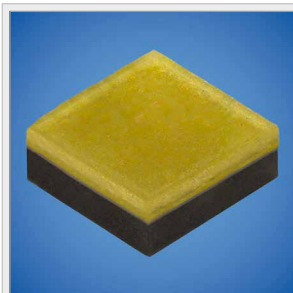

Cree® XLamp® XD16 LED First to Surpass the 280 lm/mm² Lumen Density Mark

The XLamp XD16 LED delivers a lumen density of more than 280 lm/mm², the highest level achieved by a commercial lighting-class LED. The ceramic-based XD16 LED uses the proven XQ footprint and combines breakthrough lumen density, low optical cross-talk, unsurpassed thermal contact and ease of system manufacturing to enable new designs for lighting such as color-tuning, street, portable & industrial.

For more details, please visit Cree's [XLamp® XD16 LED webpage](#)



Clever solutions for a changing world

Fulham's powerful, innovative LED drivers bring tomorrow's technology to today's luminaires.

FULHAM
HOTSPOTLED

HotSpot Plus:

The All-in-One Emergency Driver

The first fully integrated programmable LED driver, emergency LED driver, and replaceable backup battery. Reduces costs, simplifies installation, and brings emergency capability to smaller luminaires.

FULHAM
LUMO SERIES

20/25W Universal Mains Dimming Driver

A versatile, 220-240VAC dimming driver cleverly designed to work with TRIAC and ELV dimmers and potentiometers. Ideally suited for COB arrays and LED strips.

FULHAM
Lighting... Global. Intelligent. Sustainable.

Learn more at our upcoming events

Strategies in Light 2018 | Booth 408

February 13-15, 2018 | Long Beach, CA

Light+Building 2018 | Stand 4.0 A12

March 18-23, 2018 | Frankfurt, Germany

www.fulham.com

Europe | sales.eu@fulham.com +31 72 572 3000

North America | order@fulham.com +1 323 599 5000



Repro-Light - Looking for a Sustainable and Modular Luminaire Architecture

The Repro-light project aims to re-conceptualize the European lighting industry towards more sustainability and competitiveness in terms of production and time to market. This will be achieved through the implementation of modular luminaire architecture and a smart production scheme, demonstrated by the development of a reconfigurable customized LED luminaire designed to improve the customers' health.

The Project Objectives:

- **Sustainable modular architecture:** The luminaire will consist of building blocks (housing, LED module, optics), which will be stackable and can be reconfigured easily by the customers. The modules are programmable so not only the luminaire hardware (e.g. add or change light module, exchange optics, etc.) but also the software can be re-configured and updated (e.g. apply dynamic lighting) retroactively, even after it has been purchased.
- **Human Centric Lighting:** The luminaire of the future supports the well-being, health and performance of humans through optimizing the visual, biological and emotional effects of light, which is called Human Centric Lighting (HCL). Lighting parameters (intensity, light color) are varied to mimic the natural dynamic of daylight and invoke positive effects.
- **Extended IoT Connectivity:** Smart lighting increases the functionality of luminaires substantially through the collection of data (e.g. brightness, temperature, presence, etc.) and the connection to the Internet of Things (IoT) or building monitoring systems. The Repro-Light luminaire will be connected to the LiveLink system, the system of partner Trilux and will be able to adjust lighting parameters by itself by being able to collect and analyze data in an intelligent way.
- **Industry 4.0 Compatible:** The modular stackable architecture and the programmability of the Repro-Light luminaire for a higher flexibility towards the customers allows for lower production time and costs substantially. In the future, equal parts will be manufactured in high quantities at first and differentiation will only take place in the late stages of production by software, allowing more flexibility.
- **Avoiding the programmed obsolescence:** Through the integration of ICT-based components into luminaires the life cycle of LED luminaires has become substantially shorter - especially considering the long life time of the LEDs themselves. By providing the option to re-configure the hardware of the luminaire and update the functionalities of the luminaire through the software the Repro-light luminaire will not go "out of fashion". Furthermore, the LED module and the electronics can be disassembled separately, lengthening the life time of the luminaire and enabling re-use of the LED module in different applications.

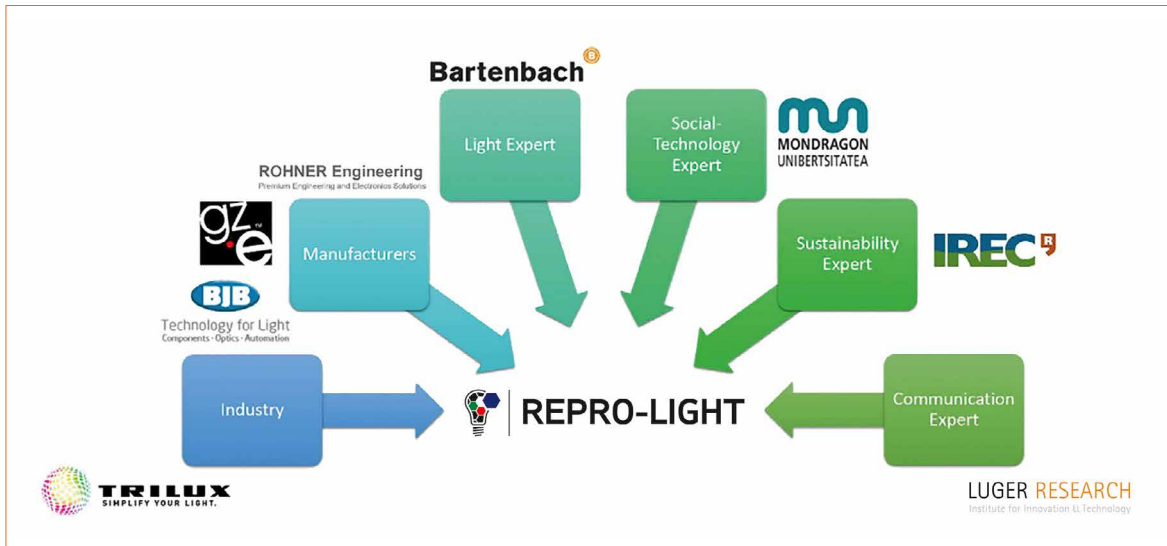

Eight partners joined forces for the Repro-Light project

Right from the beginning, the Catalonia Institute for Energy Research (IREC) was one of the driving forces for this project. Cristina Corchero, Head of Energy Systems Analytics Research Group and Gabriela Benveniste, senior researcher specialized in LCA, met with Arno Grabher-Meyer, Editor in Chief at LED professional to give him some background information on the project.

LED professional: IREC initiated this project and pushed the idea bringing together a very effective team for this research project. Can you tell us what the reasons were, what your expectations are, and when this idea was born?

Cristina Corchero: During the past 8 years, IREC has developed and implemented many projects related to innovative and intelligent lighting systems successfully. This time we wanted to go beyond technical challenges that this type of lighting presents when they are installed in highly demanding ambiances, and provide solutions that would answer to other requirements: sustainability, circular economy and fight against obsolescence. For this reason, IREC asked the Energy Systems Analytics group and the LCA team to provide their experience.

LED professional: Repro-Light is a research project that is now supported in the framework of the FOF-10-17: New technologies and life cycle management for reconfigurable and reusable customized products in the call Industry 2020 in the circular economy of the Horizon 2020 Work Program. The Repro-Light

consortium has defined clear objectives with quite detailed features to be satisfied. Is there a dominating customer request that triggered the consortium to start this research or is there a general necessity to go in this direction?

Cristina Corchero: Definitely - more and more customers are requiring products that provide not only a technical solution to their requirements, but provide an experience and have added value. It is a fact that customers are willing to be an active part when purchasing any type of goods. Furthermore, the environmental consciousness is growing among end users. It is understood that we wish to keep our level of comfort, but not at the cost of the environmental.

LED professional: Please correct me if I am wrong: The FOF-10-17 call includes life cycle management which goes beyond modularity and also concerns recycling or disposal. Does your project also recognize this part, e.g. by looking critically on the used materials and layout? I am thinking, for example, of bio-degradable materials.

Gabriela Benveniste: Absolutely - life cycle assessment, a methodology that analyses all the phases of the life cycle of a product from an environmental perspective is going to be extensively applied from the design phase of the Repro-Light luminaires up to the end of life management. Different options of materials that fulfill the technical requirements but present lower environmental impacts will be proposed. This not only applies to those materials that apparently seem to have lower environmental impacts from the beginning, but also to those that can be easily recycled or reused at their end of their life.

LED professional: The defined goals sound pretty ambitious. Did you already define technology fields that are especially challenging to finding an appropriate solution or are the requirements equally high for all components and technologies of a luminaire system?

Gabriela Benveniste: We are considering different application fields. For instance, working and office environments are application scenarios that required specific lighting solutions but they need to be

The basic project idea and its key features for a reconfigurable luminaire solution

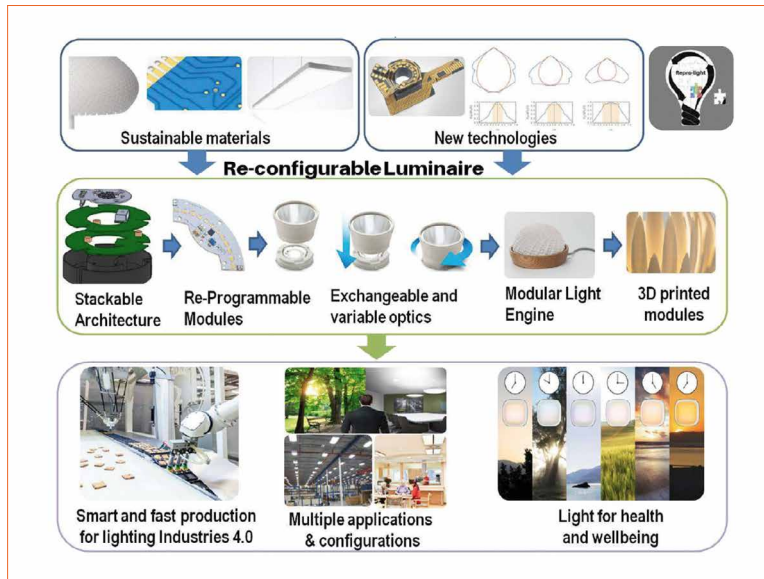

adapted to each user, depending on their working conditions (different schedules, type of work, presence of natural light, room temperature, etc.). Furthermore, these luminaires shall be easy to configure, easy to install and re-adapt if working conditions change. Another application field could be centered on the health and sanitary fields. Patients and elderly people are very sensitive to light conditions and there are many studies that prove that exposure to certain light frequencies can help them make a quick recovery. Again, these luminaires should be highly adaptable, as users may require different lighting options.

LED professional: In your features listing, you mention two key approaches for sustainability: Modularity and ICT (Information Communications Technology) based components. On the other hand this list includes features more related to the end-user requirements, including operators. These are IoT and Industry 4.0 functionalities as well as Human Centric Lighting (HCL). Are these requirements complementary or contradictory, being an additional challenge, or don't they have a strong influence on each other?

Cristina Corchero: We consider that these requirements are complementary and go hand in hand. From one side, this project aims at demonstrating how new IoT and industry 4.0 technology can help to improve the production times, provide high product adaptability and reduce energy and material consumption. On the other side, these requirements are aligned with the willingness of providing a new production paradigm that uses less to produce a high value product, and therefore are more sustainable from all perspectives.

LED professional: Until now, we have talked about technologies that are or have to be implemented in the luminaires. But finally these products have to be produced. In your project application for FOF-10-17, you are proposing a very young, still quite sophisticated manufacturing methodology, 3D-printing. Can you tell us something about this idea, and are there other sophisticated approaches in discussion?

Gabriela Benveniste: 3D printing technology is standing out as the fastest and cheapest manufacturing

technology. It assures raw material savings which also implies energy and resources savings. Implementing this technology in a conventional manufacturing line was an objective that we have in mind to build a product that, with lower costs, could achieve good quality and reduced impact.

LED professional: During the project prototypes for different use-cases will be designed. Do you already have some use-cases in mind and why were these use-cases chosen?

Cristina Corchero: The specific cases are going to be defined during the project, but as a general idea, we consider that these lighting systems can be successfully implemented in offices (working ambience), with a specific demand of lighting or specific places where light is going to improve user life conditions.

LED professional: Thank you, I think this gives our readers a good insight into Repro-Light, but perhaps you could also give us an idea about your vision and expectations after the project ends. How will the results contribute to our lives?

Cristina Corchero: Our aim is to demonstrate that another way of producing is possible, combining both the technological innovations (3D printing, Industry 4.0), user requirements (functionality, customization, durability) and environment. Lights do not only provide a unique function, but they can also provide life quality. ■

Acknowledgements:



This project has received funding from the European Union's Horizon 2020 research and innovation programme under grant agreement No 768780.

Making LED
Lighting Solutions
Simple™

We Accelerate Time to Revenue by Providing

- ▶ The Most Comprehensive System-Level Product Portfolio
- ▶ Solid-State Lighting Expertise
- ▶ Design Support Services
- ▶ Global Supply Chain and Business Solutions



www.FutureLightingSolutions.com

light+building
18.-23.3.2018 Frankfurt am Main

Visit us at our stand!
We look forward to seeing you.
Hall 4.1, Stand G10

Multi-Pixel LED Technology Opens New Horizons for Smart Lighting Applications

The evolution of Multi-Pixel LED technology has initiated a giant leap in the development of intelligent lighting systems which are most visible in the automotive industry. Now the first hybrid LED provides smart headlights with more than 1000 individually controllable pixels. Ralph Bertram, who is working on advanced LED device concepts, and Norbert Harendt, who is developing optics solutions for general lighting at Osram Opto Semiconductors, show that automotive lighting is just one of the potential areas in which intelligent selective pixel control can be applied. Options for the use in general lighting, such as information display for outdoor, indoor, retail or industrial applications, are very versatile.

Smart lighting has become an increasingly visible trend topic, not only drawing the attention of the industry as an attractive growth market, but also of the general public. Trends such as smart homes, IoT penetration, and advancements in LED technology are some of the key factors driving the market growth. Energy savings made possible by highly energy efficient LED technology, intelligent control mechanisms and sensors to regulate light settings for user comfort - as well as new concepts like Human Centric Lighting - are at the forefront of consumer's minds.

Up to now, adaptive lighting includes changing the light intensity and color in response to usage parameters like occupancy or time of day. But there are many additional application fields in which intelligent spatially adaptive lighting can provide numerous benefits to end users, and open new potential markets for solution providers.

The automotive industry traditionally leads the way in many technological developments. Today's cars often represent the most sophisticated technology owned by many consumers. Virtually every aspect of the modern automobile is high-tech, and uses state-of-the-art materials and solutions. As a result, cars have become a platform showcasing the evolution of technology as well as the potential and progress among engineers and innovators. Adaptive Frontlighting Systems (AFS), for example, help to increase driving and road safety. These systems adjust the direction of the light to offer drivers the best possible visibility by illuminating curve progressions, the side of the road, or help to protect oncoming traffic from glare through the so-called adaptive driving beam (ADB). This concept of adaptable light beams and emission characteristics of light sources is now also finding its way into

fields including shop lighting, or lighting solutions for hotels, gastronomy or business environments.

So, why didn't the transfer to spatially adaptive lighting happen earlier? Most probably because the technological challenges are even higher than with other lighting systems. Changing the path of light requires moving parts such as tilting mirrors or shifting lenses. In the past it simply wasn't possible to provide an affordable, efficient and adequately robust solution which would also fulfill the long operation lifetime required in professional lighting systems. With the continuing miniaturization of LED technology, new possibilities are arising that promise to add another dimension to adaptive lights: changing the beam pattern of a light source without moving parts.

	Office (desk)	Restaurant	Museum	Reading Light	Shop
Granularity on object	1 m	20 -100 cm	50 - 100 cm	5 cm	5 - 20 cm
Pointing distance - d	2 - 5 m	2 - 5 m	2 - 5 m	1 - 1,5 m	1 - 3 m
Light required	500 lx	20 - 200 lx	300 - 1.000 lx	100 - 300 lx	500 - 5.000 lx
Light per "pixel"	500 lm	10 - 200 lm	100 - 250 lm	0,3 - 1 lm	1 - 10, up to 100 lm
Single pixel FWHM - α	30°	2°	5-10°	2°	1-5°

Table 1: Estimated "granularity" (=smallest spot on target) and required optical parameters for different applications

Applications Fields and Requirements

Smart spatial lighting installations are already commonplace in some applications: corridors light up when you walk by, parking lots are only illuminated where people are present and the lights above an office desk or in the pantry area automatically dim down when not in use.

All this can be done by adding sensors and intelligence to both existing and new luminaires. For example, in corridors it is sufficient to light up or dim down ranges of 3-5 meters. In the office, it is already a different story: some people might want to light up only their desk and not the area around it. Others want to have a light beam on the paper they are working on. Thinking about airplane, trains or car interiors, it might be required to light up only the crossword that a passenger is solving, and not disturb the passenger in the next seat who would like to sleep. This is also a useful feature for home lighting – for example if you like reading at night while your partner goes to sleep early.

Museums or restaurants have different requirements with regards to adaptable lighting. Today, they usually have to pick one lighting arrangement with more or less flexibility through track systems where luminaires can be manually adjusted. If the arrangement of their tables or art on display is changed, the originally chosen light arrangement often doesn't fit very well. To change

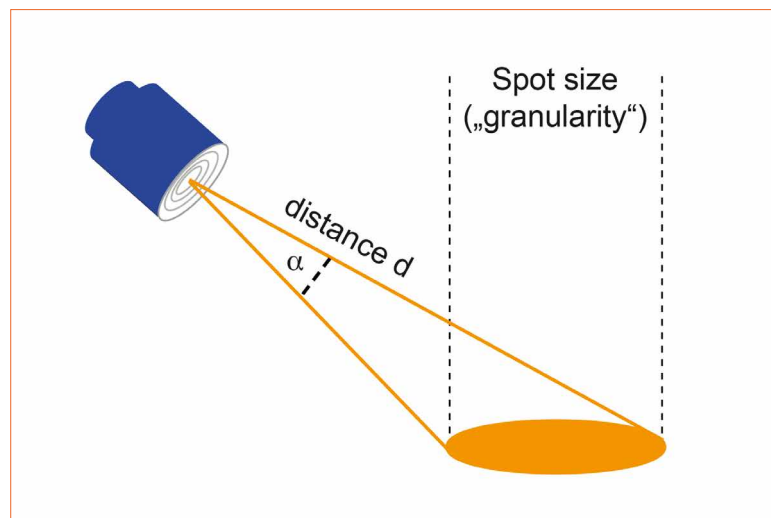

Figure 1: Spot size on the target equals "granularity" in a multi-spot source

the light fixtures, however, is time consuming and thus costly. To avoid this, novel lighting systems require digital control and a much finer granularity of the light spots, which makes it hard or impossible to realize with common means.

In shop displays, the benefits of spatially adaptive lighting are even more apparent: setting light accents by a tap on a tablet computer, even from a remote location, can greatly save effort and money associated with setting up the merchandise display. It also enables the user to change the look and feel of the display at an ad-hoc notice without even touching it.

Technical Challenges

Each of these application fields has different requirements towards the necessary light levels as well as the "granularity" – meaning the size of each "pixel" that is to be illuminated. In table 1, we tried to estimate

typical scenes including feature sizes, the light source distances and the resulting beam angles.

Looking at the set of parameters, the biggest challenge lies in the very fine granularity of each single beam. Osram has started to demonstrate this kind of application scenario with the "Omnipoint" concept in 2015 [1]. In this scenario an assembly of almost 100 Osram Square High-Power LEDs is placed on a hollow sphere in a downlight configuration. Each LED, equipped with its own narrow-beam optics, points to a different direction in the room. By switching or dimming each LED individually, the light distribution in the room can be smoothly adapted.

With this enormous effort in terms of mechanics and optics, the fixture is able to fulfil the requirements for a demanding office application as explained above and gets closer to fulfilling shop lighting specification. However, applications aiming at

Figure 2:
Detail of the
“Omnipoint”
demonstrator: Each
LED with its own lens
shines into a different
angle and therefore
illuminates a different
area in the room



small object illumination, like a reading light or sophisticated merchandize illumination, demand even more pixels and smaller beams. In order to develop a system fulfilling these requirements, a different, more integrated technical approach is necessary.

More but smaller pixels call for a dense arrangement of LEDs that can be addressed individually. Miniaturization of the system and its components is therefore a key requirement, which would allow the use of common optics for hundreds of light sources. In turn, this is essential to keep the system simple and affordable.

Figure 3:
Array of surface-
emitting Chip Sized
Packages

Looking at the requirements in table 1, the necessary light levels per pixel for many applications can be fulfilled by using an arrangement of 1 mm^2 LEDs, each able to deliver a typical 100 lm, going up to 300 lm in overdrive mode.

However, in order to illuminate the whole room with these beams, hundreds or even thousands of pixels are necessary. Thus, it is essential to have high-luminance emitters that can be packed very closely together. Figure 3 shows an array of a new chip sized “Package” under development, which is not larger than the chip itself. It has, in fact, been designed as a

surface-emitting chip without any package or frame around it. Its compactness is perfectly suited for dense arrays while still having a size manageable by standard SMD equipment.

An array of this new clusterable LED provides the best possible compact size realizable by LED components and will help to fulfil the requirements of numerous application scenarios. But even with this accomplishment, in some cases the overall LED array will amount to a size difficult to manage by optics. Additionally, driving the LEDs would still need to be realized in a passive

matrix arrangement with outside electronics. The next step in the integration process will therefore be the multi-pixel LED.

Heading Towards the Multi-Pixel Light Source

To date, adaptive LED lighting systems, including automotive headlamps, have operated with individually controlled chips for each illuminated area. Now the evolution of multi-pixel LED technology is initiating a giant leap in the development of intelligent lighting systems, which are observable in the automotive industry.

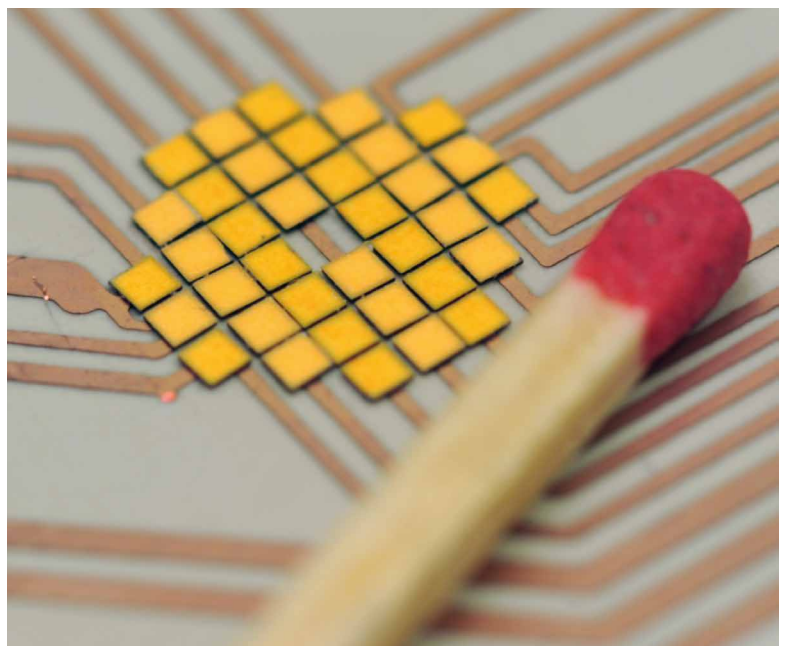

Under the “ μ AFS” research project (pronounced “micro AFS”), funded by the German Ministry of Research and Education a group of German companies worked for three and a half years up to September 2016 on the groundwork for a new class of energy-efficient LED headlamps for adaptive front-lighting systems. Osram Opto Semiconductors took on the leading role as project coordinator and contributed its extensive expertise in the area of LED light solutions for the automotive sector as well as in the area of chip and conversion technologies.

The project partners, have developed a pixel-light source with 1024 individually controllable light points. These provide about 3 lumens (lm) at only 11 milliamperes (mA) for an individual pixel surface of 0.115x0.115 mm from a closed emission surface of 4.00x4.00 mm with a grid size of 0.125 mm. They are arranged in an array of 32x32 on an active matrix IC, so each pixel can be individually addressed. Developed originally for the automotive headlamp application, it can possibly also enable the fine granularity needed for shoplighting and reading light applications.

Another major advantage are the control options, e.g. through the interaction between a camera and a controller. The camera acts as the “eyes” of the system, capturing the information about the surroundings and forwarding it to the controller. This “brain” processes the information and forwards a suitably adapted light distribution pattern to the pixels in digital format. Each of the pixels can be switched on and off with different currents more than one hundred thousand times a second, and can therefore be dimmed. Depending on the situation, the system decides which pixels will be affected. In automotive applications, traffic signs (for example) will be illuminated so drivers can see them clearly without being dazzled by the reflected glare from their own headlights.

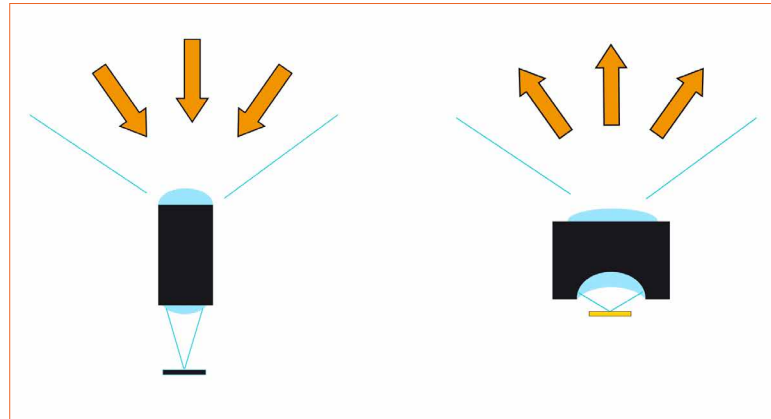

Figure 4: Difference between an imaging camera system (left) and an illumination system (right) - note the large angular aperture needed at the light source of the illumination system

Automotive lighting however is just one of the potential areas in which intelligent selective pixel control can be applied. Options for the use in general lighting, such as information display for outdoor, indoor, retail or industrial applications, are very versatile.

Challenges and Opportunities for Optics Designers

Moving from discrete lenses to an integrated array, we also face significant challenges in optics design. Illumination optics in the traditional sense always is about blurring the light source and not creating an image of it on the wall. It is also about removing any focal points so a spotlight emits a single, homogeneous, slightly diverging beam.

If we want to create an optical system that can send light from different pixels into different directions, we need to get back to an imaging system again. In optics terms, this is the simple task to convert a spatial pattern into an angular pattern.

The task is not much different from what a wide angle (“fisheye”) lens does when used for camera imaging in the opposite way: it projects rays coming from different angles to different camera pixels on the detector. It is also not so much different from an image projector optics that brings light from different points on the image to different angles in the room.

However, using LEDs as a source, the major difference is the acceptance angle as illustrated in Figure 4: For a camera lens, it does not matter at what angle the rays hit the sensor. In projectors, the light is usually pre-collimated so the image is formed from light that is more or less parallel and the optics only needs to accept a limited range of incoming angles. In addition, efficiency is not the primary target for these systems.

For our system of pixels formed by single LEDs, each pixel emits light into the full hemisphere. Thus, the optics needs to not only transform a spatial into an angular pattern but also catch as much of the light emitted as possible, - also the light emitted to the sides - and bring it to the right direction. This is definitely not possible by standard optics and needs a complex optics design with several, relatively large lenses. Since it is still an illumination optics, ultimate requirements towards image quality are not necessary. However, the demands for color correction are high in order to transfer a 3 MacAdams steps distribution of the light source to the imaging area. Either way, a slight “blurring” of the image is required to hide the structure of the LED chips in the room.

This is definitely a new, interesting task for optics designers: merging the “two worlds” of imaging optics and illumination optics to create really novel solutions for spatially adaptive illumination.

Figure 5:
Artist's view of an
adaptive shoplight
system



Competing Technologies

Switching pixels on and off does not require new technology. Digital projectors, both with LCD as well as micromirror technology, are available and offer millions of pixels. However, these are devices designed for the display of information, not for illumination purposes. Thus, they operate with RGB colors - which is perfect to display images but will create a horrible color impression when used as a source to light up a room. In addition to that, they operate by permanently creating a high light level and absorbing the light again at pixels that should be dark. This is not only highly inefficient, it also ends up with limited black and white contrast.

Using an LED light source where pixels only light up when their light is actually needed is the enabler for an adaptive system energy-efficient enough to be used for General Lighting purposes. It also allows

for the design of systems with smaller heat sinks, and passive cooling without the offending noise of a fan is possible.

Since the technology is extremely robust, it can also be utilized in more harsh environments like outdoor lighting. It could therefore be introduced into architecture lighting or mounted on moving fixtures in stage and movie lights.

Conclusion

When realizing "adaptive lighting", light levels and color temperatures as well as the distribution of light emitted by each single luminaire can be changed to really create different lighting scenes during the course of the day or be adapted to the situation.

First demonstration systems by O researchers based on single LEDs have been showcased with the "Omnipoint" system,

which impressively demonstrated the concept. Since then, miniaturization of light sources enables shrinking of form factors and adding more and more features. Realization of designs with chip sized packages (CSP), especially with the most compact new LED generations, allows adding more and more pixels and a flat design. In the future we will see even more pixels and integrated (active matrix) designs when LED sizes really enter the micrometer scale.

Multi-pixel LEDs are in the early stage of coming to the market with additional options for applications in general lighting. This technology will take lighting to the next level since it adds another dimension to adaptive lighting: spatial steering of the light, without any moving parts or compromise to the high level of energy efficiency we are used to with LEDs. ■

References:

[1] Video reference: <https://www.youtube.com/watch?v=ueQ-1OtQ80A>

guangzhou international lighting exhibition

23rd

The most influential and comprehensive lighting
and LED event in Asia

9 – 12 June 2018

China Import and Export Fair Complex
Guangzhou, China

www.light.messefrankfurt.com.cn

Contact

Messe Frankfurt (HK) Ltd

Tel: +852 2238 9969

Fax: +852 2519 6079

light@china.messefrankfurt.com



光亞 · Guang ya



messe frankfurt

Thermal Simulation Tool for LED Design Requirements

Light-emitting diodes (LEDs) are used and accepted in many areas of lighting technology today. But without the right thermal design, LED lamps would not be viable. Chris Aldham, Development Manager at 6SigmaET explains why keeping key components within narrow temperature limits is often critical, why this makes thermal simulation important to LED device designers, and how to select the right thermal management simulation tool for this task.

Once seen as the ‘light source of the future’, LEDs are rapidly becoming the norm. The design of LED products is a complex multidisciplinary problem, and thermal design, in particular, is critical to a device’s performance and lifetime. With the right thermal simulation tools, development teams are better able to deliver products that match reliability, form factor, and performance goals.

Design Challenges

LEDs are highly efficient – more so than most “traditional” lighting technologies – thanks to the direct conversion of electrical current to optical radiation in the semiconductor. However, despite being significantly more efficient than incandescent or fluorescent lighting, a high amount of electrical power in LEDs is still converted to heat rather than light – and the higher the current, the more heat is created.

This excess heat must be conducted away from the LEDs: this is because the semiconductor material is limited to a maximum temperature, and its characteristic properties – such as forward voltage, wavelength and lifetime – may vary with temperature.

As temperature increases, the light output of LEDs can decrease by as much as 10%. Similarly, maintaining the desired light color is temperature-dependent.

The expected operating life of LED lamps – usually somewhere between 25,000 and 50,000 hours – is also closely linked to the temperatures experienced within a lighting fixture.

Ultimately, only adequate thermal management can facilitate the full exploitation of LED performance and efficiency during operation. Proper cooling – of both the LED

itself and the aluminum electrolytic capacitors employed in driver circuits – is central to the design process.

These fundamental challenges have been further exacerbated by the continuing market demand for ever-more compact fixtures and lamps.

Smaller lighting fixtures are needed in portable applications, such as entertainment lighting, so that they can be transported and handled more easily, and are less obtrusive in use. In retrofit applications – everything from street lamps to domestic downlights – designers need to keep sizes and shapes within the limits defined by existing fixtures. This normally includes squeezing the electronic driver circuit inside the fixture, and – in the case of directional lighting – the LED emitter module and lenses as well. This means that the heat must be dissipated from an ever-decreasing amount of space.

The end application must also be taken into account at the design stage. LEDs are deployed in a wide variety of environments; in automotive applications, for example, devices may need to operate at ambient temperatures up to 85°C. This means that manufacturers must build their devices to meet customer requirements for output, color and operating life with the operating

temperature in mind, and allow for any temperature-induced performance shift.

Managing Heat Transfer

For designers, the aim of thermal management is to transfer the heat generated by the device into the ambient air to prevent components overheating. The scope and complexity of thermal management depends on the amount of heat, the size of the source, and the anticipated ambient conditions. Dealing with these factors requires a clearly defined heat transfer path.

Typically, the system heat transfer path begins at the heat source (semiconductor junction layer), and travels via the PCB, heat sink, and housing before finally reaching the ambient air (Figure 1). The challenge lies in managing this heat transfer within the constraints of the power class and application of a device.

As a rule, the thermal management of an LED system can be broken down into three system levels: the LED itself, the submount/PCB, and the cooling unit. The heat path for system heat transfer can be described in the same terms. The heat generated in the LED barrier layer is transmitted through the LED housing (package) via the soldered joint and on to the carrier (PCB). At PCB level, the heat can be transported to the heat sink by various design measures (horizontal and vertical thermal conductivity). From the cooling unit (e.g. heat sink, system housing), the heat is finally transferred to the ambient environment through natural convection and thermal radiation.

At each stage, designers are faced with a number of crucial decisions in order to optimize heat transfer.

At the LED level, the type of housing has a significant impact on thermal management. To take a couple of examples, lead-frame-based LED housings and ceramic-based LED housings offer different approaches to heat transfer for designers.

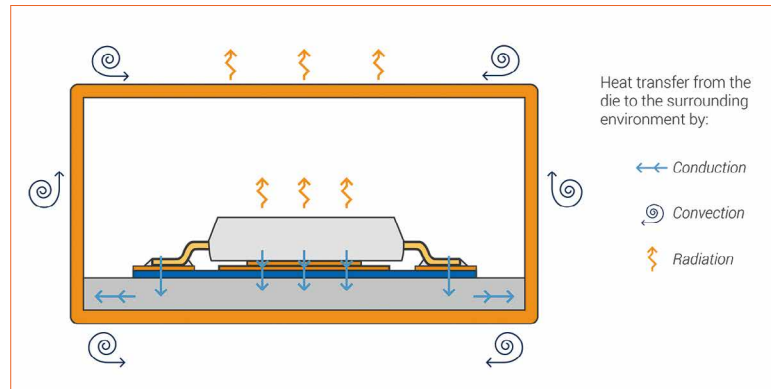

Figure 1: Heat transfer in an LED system

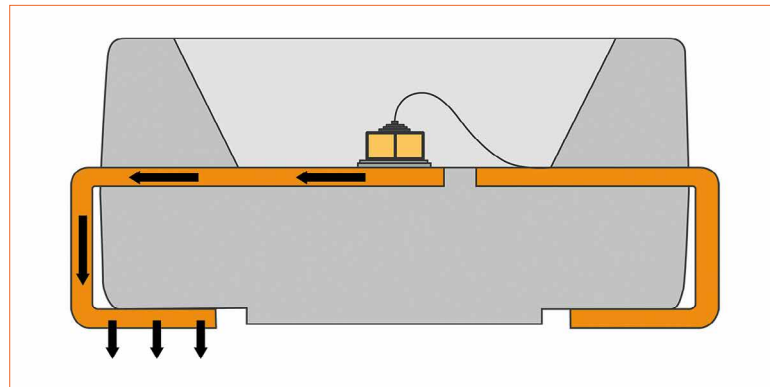

Figure 2: Heat conduction via lead(s)

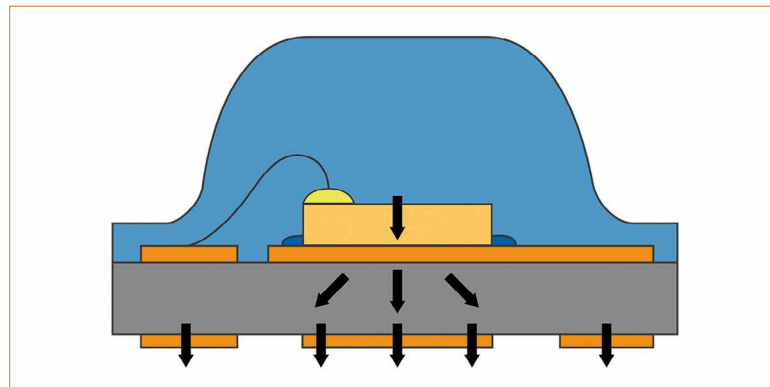

Figure 3: Heat conduction via ceramic substrate

In the case of a lead-frame-based housing (Figure 2), the semiconductor chip is mounted on a lead frame that, in most cases, consists of a plated copper alloy. The connection can be glued or soldered. Starting from the barrier layer, the heat is primarily dissipated from the package via the chip and lead frame. The amount of heat transfer that takes place via the bond wire is insignificant.

In the case of LED packages based on ceramic substrates (Figure 3), the semiconductor chip is attached to the metallization layer of the ceramic. The good thermal conductivity of the ceramics enables heat spreading in conjunction with the metallization layer. The heat produced in the

semiconductor is distributed via the metallization layer and ceramic base material, and transmitted to the PCB via the solder pad.

Knowledge of the heat conduction path in the LED housing is important, as it enables the correct choice of subsequent system components (PCB, solder pads, etc.).

The thermal design of the PCB presents designers with another range of decisions (Figure 4). Heat can be transferred over the PCB (horizontal conduction) or through the PCB (vertical conduction).

In both cases, conduction paths are impacted by a range of factors: where the LEDs are positioned on

Figure 4:
Various thermal design elements at PCB level

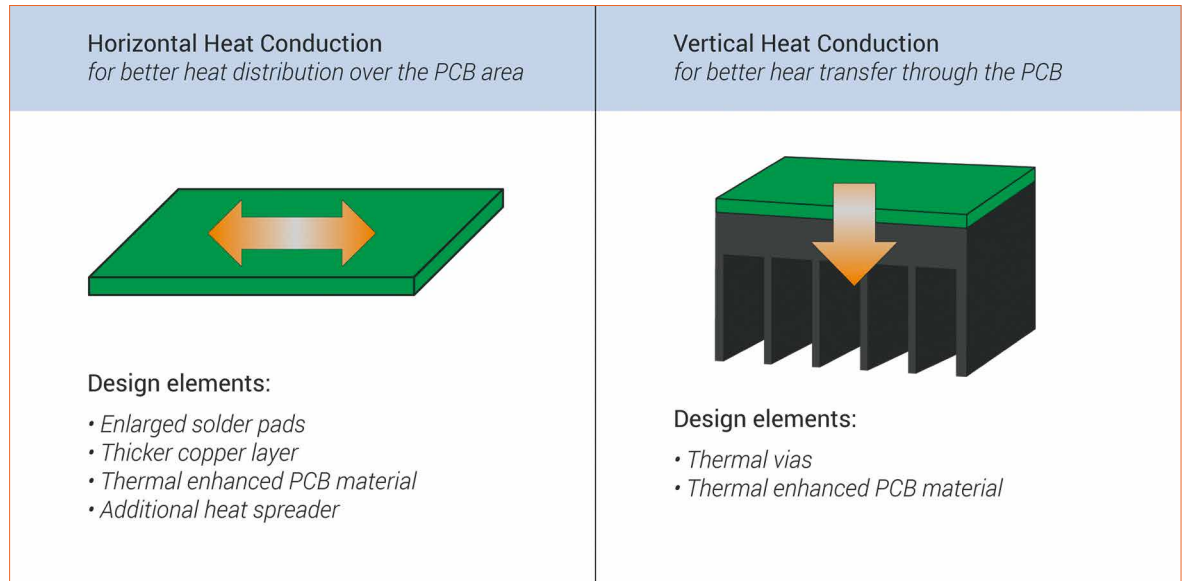
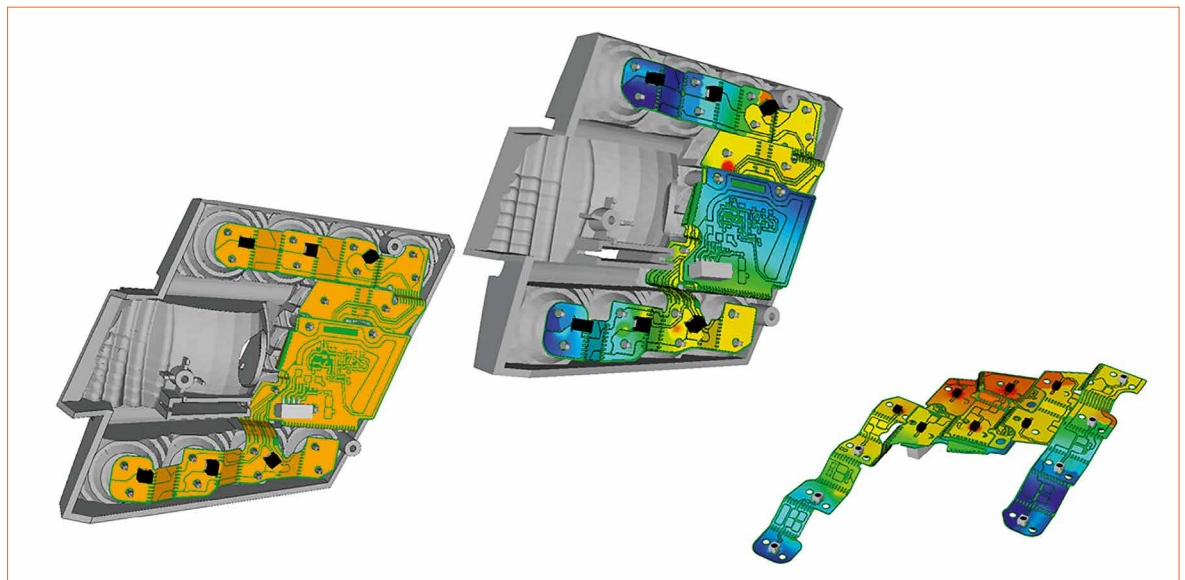

Figure 5:
Thermal simulation in automotive LED applications



the PCB, to what level thermal losses need to be dissipated, and whether there are other potential heat sources in proximity. Moreover, shrinking LED devices adds further complications. Smaller devices have a reduced contact area with the board; previously, older and larger packages meant that more heat spreading could be done on the device itself. Increasingly, these smaller devices are forcing this process to take place on the PCB instead.

These factors then impact material selection, the surface area required, the required thickness of the conducting layers, and the need for thermal vias in the PCB design.

The final system layer is the point of transition to the ambient environment. From this point, heat can only be dissipated effectively via convection or radiation due to the low conductivity of air.

Most LED designs rely on natural convection, rather than forced convection. This means designers require heat sinks that provide maximum surface area - rather than employing active methods like fans, or more sophisticated methods such as Peltier elements, heat pipes or water cooling.

The Importance of Simulation in LED Design

The above factors indicate why thermal design is such a significant

challenge in the design of LED lighting products. As stated previously, LED lighting designers need to know that their devices will meet specifications, often in very challenging environments. It is unacceptable to provide customers with LEDs that do not provide the desired color or expected lifetime.

6SigmaET's own research has highlighted that nearly two thirds of engineers [1] tend to 'over engineer' their designs, rather than use tools to optimize thermal performance. When it comes to LED lamps, it is not possible to rely on "rules of thumb" due to size constraints and other factors.

There are many variables to consider, and a range of potential

design options to choose from. Thermal simulation is the only way to assess different cooling concepts with known marginal conditions and loads. It allows designers to identify thermal issues and to experiment with different LED packages, PCB materials and cooling devices - without the cost of creating prototypes. Using thermal simulation in this way lets LED designers ensure that their designs meet performance requirements. This makes thermal simulation an essential component in the design of LED lighting.

So, what are the key features LED designers should be looking for in thermal simulation tools?

Thermal Simulation Tools in Practice

Increasingly, thermal simulation tools are absolutely essential. They are not just a “nice to have” anymore. One of the key drivers is that the average time to market for a product is now so short. So while using simulation in tandem with physical testing, CFD tools are required to save significant time in the development process. There is simply not the time available to perform extensive physical experiments.

As well as reducing the reliance on physical testing, the use of dedicated thermal simulation software offers other benefits, including a reduction of design risk and a 10-30% improvement in cooling for LED products. Overall, it can be estimated that it saves anything from a few weeks to several months in terms of total time to market for clients.

Key features for any thermal simulation tool are:

- **Complex geometry handling:** Most thermal simulation tools can cope easily with square or rectangular shapes - but LED lamps are rarely, if ever, square. As a result, a tool is needed that can easily model and solve for the more rounded or circular shapes expected in LED design
- **Large model processing:** OTS sees that its design models are becoming larger and increasingly complex. For several of its LED projects, its models have comprised of as many as 5-15 million grid cells. The tool needs to handle these large models without becoming too slow or hard to work with
- **Fast testing of multiple design variations:** The ability to handle large models is particularly crucial when performing sensitivity studies. To truly optimize a design, quick testing of multiple design variations – placement of components, enclosure materials, environments etc. – is essential to ensure the product will work as required. Choose a tool that is designed to make this process as easy as possible

Conclusion

There is simply no avoiding the fact that without the right thermal design, your LED lamp will fail rapidly. However, optimizing the thermal design of any LED lighting product is a significant challenge, and designers need to have the right tools. If you are struggling with any of factors described above, then it is probably time to re-assess your simulation tools. ■



Figures 6&7: Simulation models of two different LED replacement lamp designs

Acknowledgements:

The author thanks Osram Opto Semiconductors GmbH and Alpha Numerics GmbH for their support and providing the figures 1-4 and 5 respectively. In particular, the author wants to thank Rainer Huber of Osram Opto Semiconductors GmbH for his help in preparing the article and Norbert Engelberts, founder of OTS for identifying the key features for thermal simulation tools.

References:

- [1] <http://www.6sigmaet.info/media-centre/whitepapers/the-heat-is-on/>

Flicker-Free Control of Individual LEDs in Matrix Headlights

LEDs combine design flexibility with practical, robust circuitry, enabling automotive designers to produce striking headlight designs matched by exceptionally long life and performance.

Keith Szolusha, Sr. Design Leader for LED driver products at Linear Technology, and now part of Analog Devices explains how automobile designers are increasingly incorporating LEDs in lighting because they can be arranged in distinctive eye-catching designs - helping distinguish new models from old, or high end from economy.

There is no question that automobile LED lighting has arrived, but it has not yet reached its full potential. Future models will feature more LED lights, including new shapes and colors, and more control over the individual LEDs. Simple strings of LEDs will give way to matrices of LEDs that can be individually dimmed via computer control, enabling unlimited real-time pattern control and animation. On the example of the LT3965 matrix LED driver and a combination with the LT3797 boost-then-dual-buck mode drivers it will be shown how advanced driver technology makes it easy to take the next step in automotive lighting design.

I²C Control of Eight Power Switches with a Single IC

A basic LED headlight design operates with uniform LED current, and thus, uniform brightness. But this leaves much of the LEDs' potential on the table. Matrix headlights take advantage of the innate abilities of LEDs by enabling control of the brightness of individual LEDs within LED strings.

It is not difficult, in theory, to address the individual LEDs in a matrix via computer-controlled power switches, allowing individual LEDs to be turned on or off, or PWM dimmed, to create unique patterns and functions. Each LED (or segment of LEDs) requires either its own converter or its own shunt power switch. It is possible to build a matrix driver with traditional driver/converter ICs that include a serial communications feature, but once more than two or three switches are needed for a matrix of LEDs, designing a discrete component solution becomes challenging, involving a matrix of components that exceeds the size of the LED matrix.

The I²C 8-switch matrix LED dimmer makes it easy to control large or small LED matrices (up to 512 LEDs).

Figure 1 shows the driver in action on the demonstration circuit.

Its highly integrated design (Figure 2) minimizes component count. The individually addressable channels can be used to control LED matrices in many ways.

Control options for LED matrices:

- Each driver can control eight dimming channels - eight LEDs or eight clusters - within a string of LEDs
- The eight channels can control the individual red, green, blue and white light on two RGBW LED modules for adjustable brightness or changing color of dashboard or trim lighting
- Multiple drivers can be individually addressed on a single communications bus to multiply the strings in a large array
- One driver can control multiple LEDs per channel, or channels can be combined to efficiently control a single LED at higher current

When combined with a suitable constant-current LED driver, the matrix dimmer LED driver allows the individual LEDs to be computer-controlled in headlights, daytime running lights, brake and tail lights,

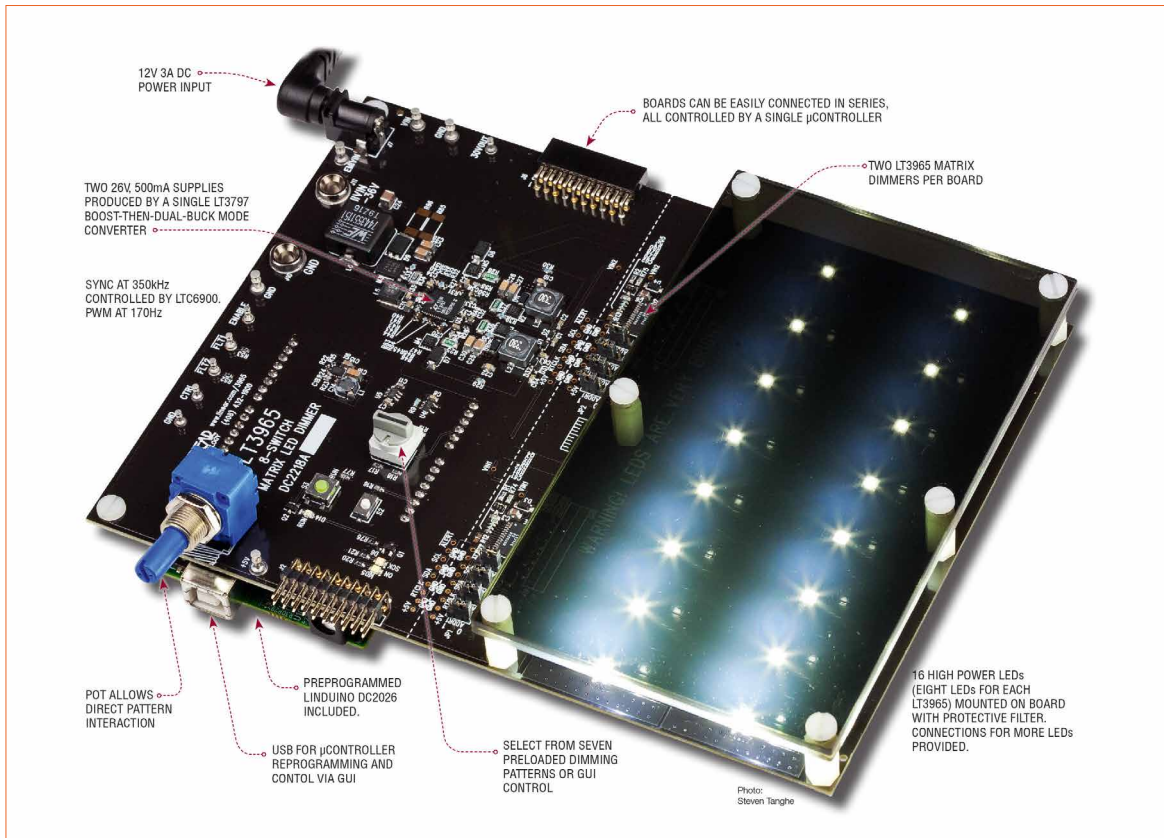

Figure 1: LED matrix dimmer demonstration circuit run as a Linduino™ shield. This demonstration circuit runs headlight, turning light, tail light and trim patterns and can be evaluated with a graphical user interface via a USB cable

side-bending lights, dashboard display and other trim lighting. A built-in automatic fault detection protects individual LEDs in case of a failure and reports failures to the microcontroller.

The 60 V driver includes eight integrated 330 m Ω power switches, which can be connected to one or more LEDs. The power switches act as shunt devices by turning off or PWM dimming the LEDs on a particular channel. The switches create eight individually controlled brightness channels (up to 256:1 dimming ratio) and eight fault-proof segments of an LED string.

It can handle a string current of 500 mA when all eight power switches are on at the same time (all LEDs off). The switches can be connected in parallel and run at 1 A through four channels of LEDs as shown later in this article. Regardless of the number of LEDs or current, the LED string must be driven by a properly designed converter that has the bandwidth to handle the fast transients of the matrix dimmer. Some reference designs are included in this article.

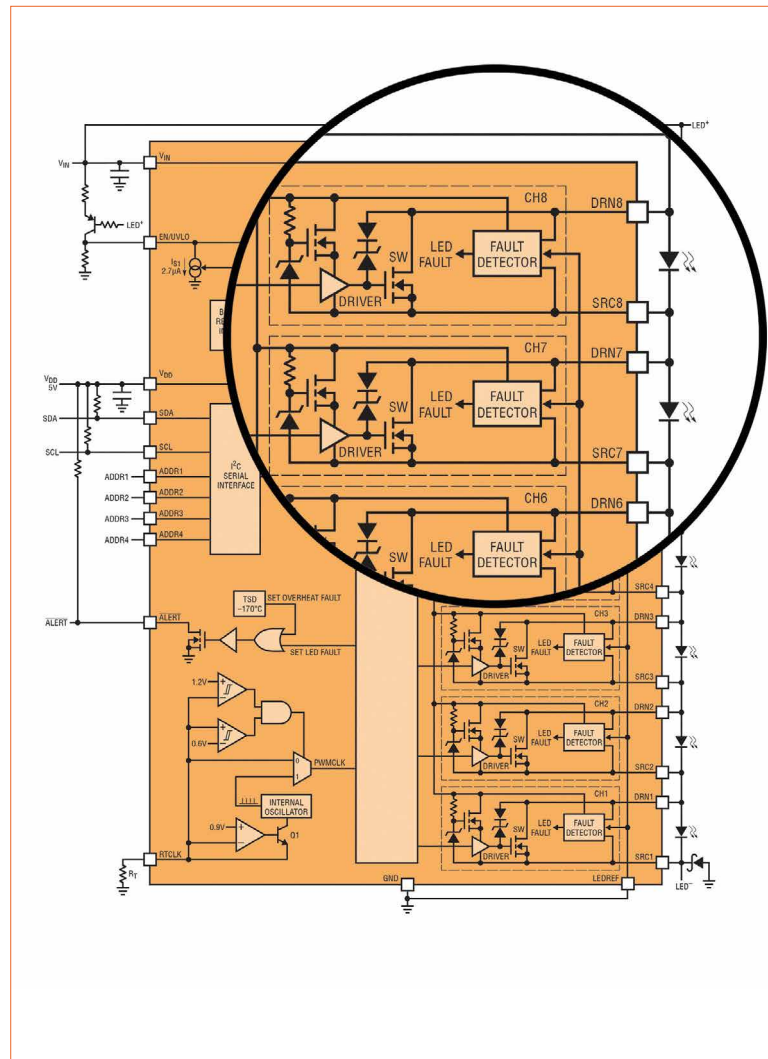

Figure 2: 60 V 8-switch LED matrix dimmer block diagram reveals eight power NMOS shunt switches for brightness control, a fault flag and I2C serial communications interface

Boost-then-Dual-Buck Mode Drives Two Strings, 16 LEDs at 500 mA with Two Matrix Drivers

The eight shunt power switches of the matrix LED drivers control the brightness of eight channels of LEDs at 500 mA. The string voltage of the 8-LED matrix dimmer system can be between 0 and 26 V, depending on how many LEDs are on or off at a given time. The recommended converter topology to drive these LEDs is a 30 V step-down converter with high bandwidth and little or no output capacitor. This step-down topology requires that 9–16 V automotive input is “pre-boosted” to a 30 V rail from which the step-down regulators can operate.

The triple output LT3797 LED controller conveniently serves as a single-IC solution for both the

“pre-boost” and step-down functions - it can be configured as a step-up voltage regulator on one channel, followed by step-down LED drivers on the other two channels. Each of two step-down LED drivers can drive a string of matrix-dimmed LEDs. This topology has a number of advantages, most notably, regardless of whether the LED string voltages are above or below the battery voltage, the circuit continues to function optimally.

Figure 3 shows the schematic of the demonstration board shown in figure 1, a boost-then-dual-buck mode matrix dimming headlight system with 16 LEDs at 500 mA. Each LED can be individually controlled to be on, off or PWM dimmed down to 1/256 brightness. The 350 kHz switching frequency is outside the AM band (good for EMI)

and the resulting 170 Hz PWM dimming frequency, generated from the same 350 kHz clock, is above the visible range. With the system properly synchronized, the matrix headlight operates flicker-free.

The LT3797 buck mode converters are optimized for extremely fast transients with little or no output capacitor and properly compensated control loops. These >30 kHz bandwidth converters tolerate fast LED transients as the LEDs are turned on and off and PWM dimmed at will. A filter capacitor placed on the LED sense resistor replaces a pole in the control system that is lost when the output capacitor is reduced or removed for the fast transient performance of the matrix dimmer.

Figure 3: Matrix LED dimmer system with boost-then-dual-buck mode LED drivers and two matrix dimmers that drive 16 LEDs at 500 mA from a car battery. I2C serial communications control the brightness of individual LEDs and check for LED and channel faults

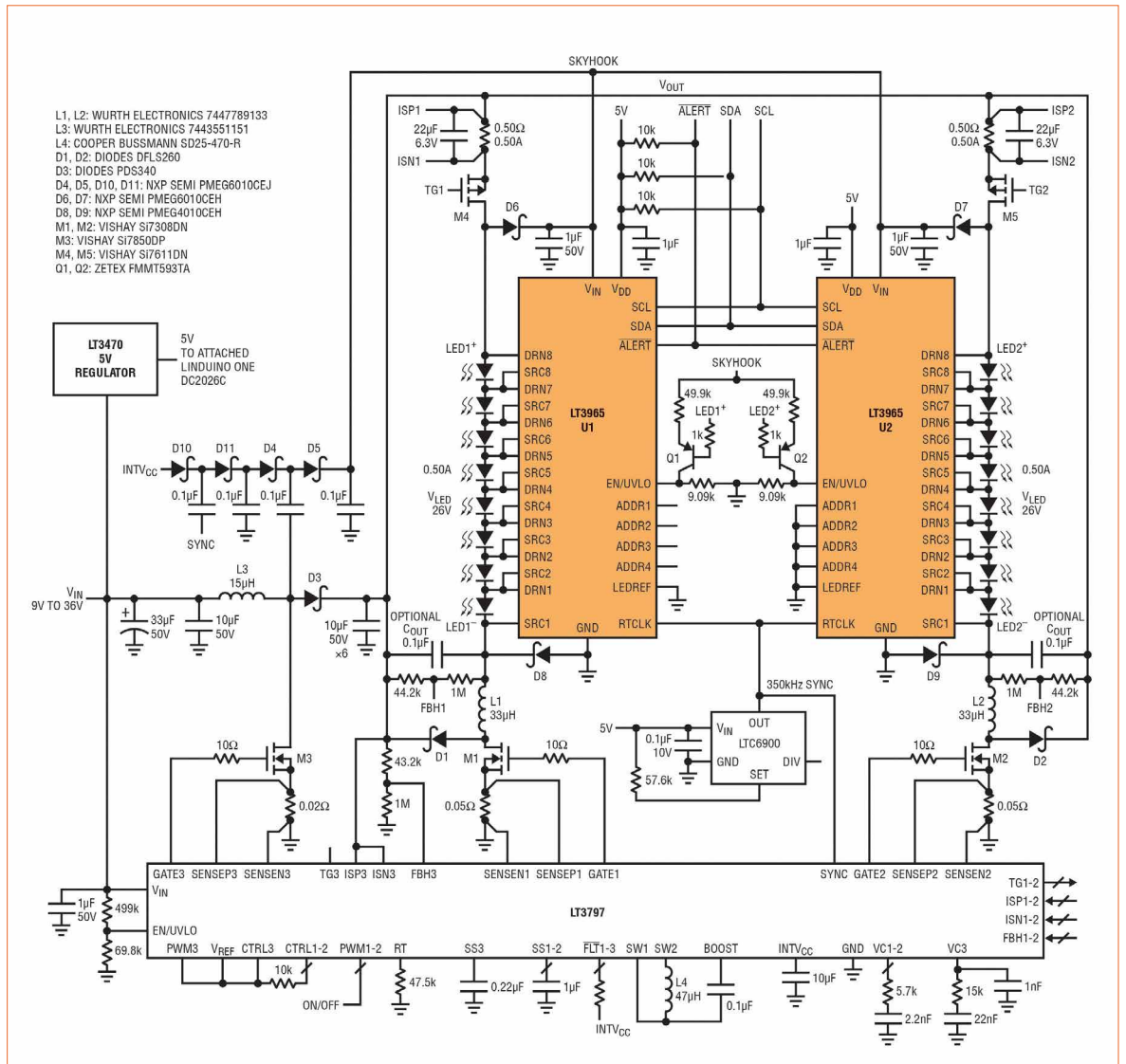

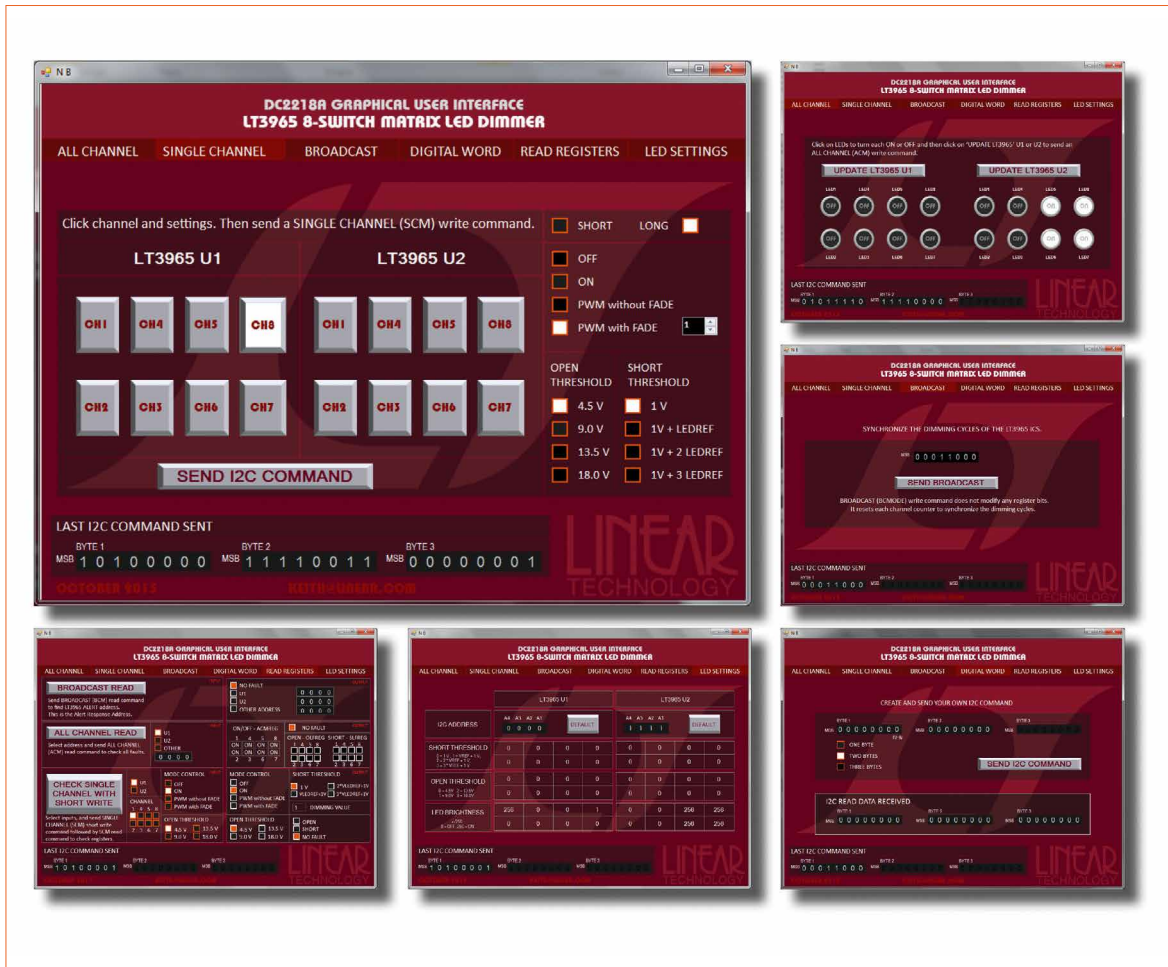

Figure 4: The PC-based interface allows designers to access control and monitoring of the LEDs

A charge pump from the switch node is used to power the matrix LED drivers' VIN pin more than 7 V above the LED+ voltage to enable the top channel NMOS to be fully enhanced when driven. The low RDs(ON) NMOS switches enable high power operation without the IC getting hot, even when all eight shunt switches are on, turning the entire LED string off. In this case, the LED driver survives the virtual output short created by all eight shunt switches without any issues, and is ready to quickly regulate 500 mA through the next LED that is turned on.

Demonstration circuit from figure 1 features the system shown in figure 3 and operates a matrix headlight with an attached I²C microcontroller via the Linduino™One demo circuit. The used demo Board, operated as a large Linduino shield, has up to 400 kHz serial code that generates different headlight patterns and interfaces with the graphical user interface (Figure 4).

Within the GUI shown in figure 4, LED brightness and fault protection functions can be examined with “All Channel Mode” and “Single Challenge Mode” commands, as well as “Fault Check” read and write commands to check for open and short LEDs. Flicker-free operation, fault protection and transient operation can be examined with this demonstration circuit system. DC2218 can be plugged directly into a 12 V DC source and it can be controlled by a personal computer running the GUI or reprogrammed from a simple USB connection.

1 A Matrix LED Driver Using Parallel Channels

The LT3965 can be used to drive matrices of 1A LED channels. It is easy to connect the power switches in parallel so that two power switches split 1 A of LED current and each driver controls four 1 A channels. One way to use parallel power switches for higher

current is to run each of the anti-phase parallel switches for only 50% of the PWM period. By alternating and running 1 A through a single NMOS power switch for half the time, the effective heating is about equal to running 500 mA through the same NMOS all of the time.

Figure 5 shows a 1 A matrix headlight system using eight LEDs driven by two matrix LED drivers and another boost-then-dual-buck mode IC. When PWM dimming, the IC uses a unique 1/8-cycle phasing of the eight switches, as shown in figure 6. In this 1 A matrix system, boost-then-dual-buck mode LED drivers channels are combined in parallel pairs, so that paired channels are anti-phase, 180° from each other; specifically pairing channels 8 and 4, 7 and 3, 6 and 2, and 5 and 1. Parallel channels alternate shunting, effectively doubling the PWM frequency, with the advantage of spreading out the shunted current and heat. For this to

More than One LED per Channel

The matrix driver can support one to four LEDs per channel. Although it can be advantageous to individually control every single LED for fault protection or high resolution patterns, it is not always necessary. Using more than one LED per channel reduces the number of matrix dimmers in a system and is enough to accomplish the patterns or dimming required for some designs. Segments of headlights, signal lights and tail lights can have up to four LEDs with the same brightness. Emergency LED lights can have sets of three and four LEDs that blink and wave with the same pattern.

The circuit in Figure 7 demonstrates a two-LED-per-channel system - it has the same number of LEDs as the circuit in Figure 3, but uses only a single matrix dimmer instead of two.

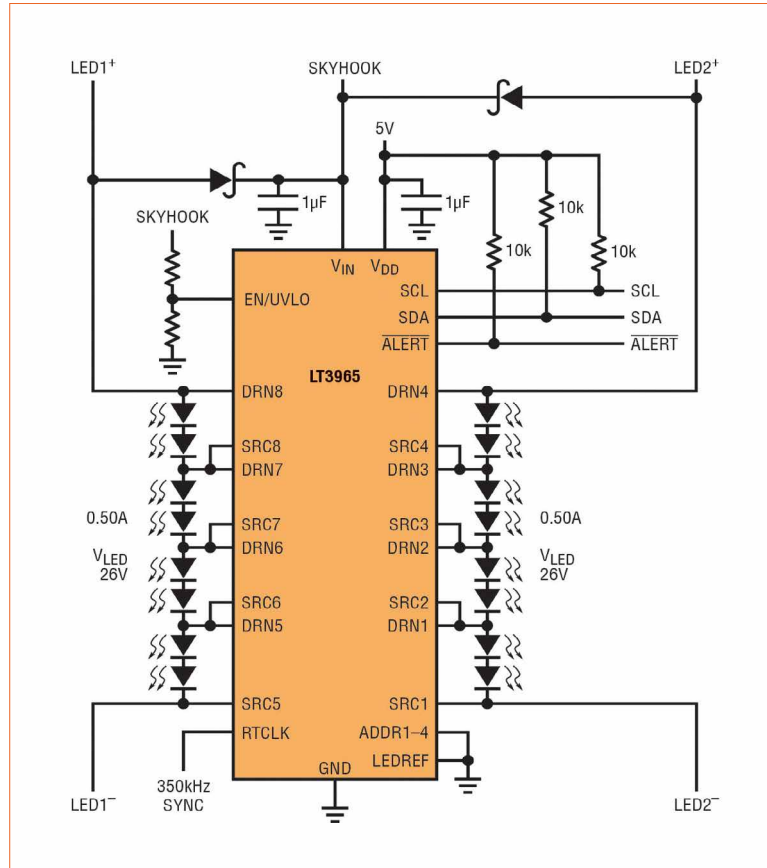

Figure 7: The flexible matrix LED driver can drive LED channels on independent LED strings and can drive between one and four LEDs per channel. (Complete driver circuit is similar to figure 3, but with only one IC, as shown here)

AC Module Series



Various choices of voltages create more flexibility in luminaire design

AC PLCC Module



Power Line Regulation

- Constant power supply while working on different voltage environment (220V-300V)
- Percent flicker <20%

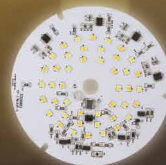

Triac Dimming

- 3-stage color dimming (2700K/ 4000K/ 5700K)
- Smooth brightness adjustment (from 10% to 100%)

AC COB Module

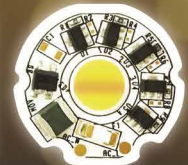
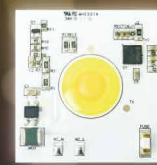

Dim to Warm (Triac Dimming)

- Color temperature between 2000K and 3000K.
- Low THD (<20%)



Figure 8:

The LED matrix driver designs shown in this article feature minimal to no cross-channel transient effects. For instance, transitioning half the channels - here, simultaneously turning on two and turning off two - has little to no transient effect on the other four, untouched channels. The non-transitioned channels remain flicker free

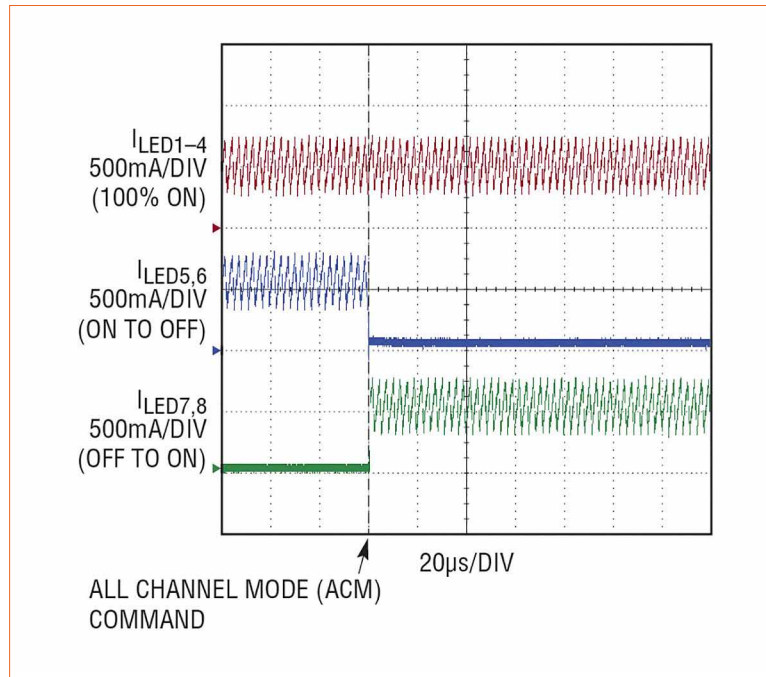

When an I²C command tells the LT3965 to turn on, off, or dim a channel, it affects the two LEDs that are controlled by that channel's shunt power switch. To stay within the voltage limitations of the IC, the 16 LEDs at 500 mA still need to be split into two series LED strings as they are in Figure 2. The same boost-then-dual-buck mode circuit in figure 2 can be used, but only a single matrix LED driver controls the brightness of the two strings. This demonstrates how each NMOS shunt power switch inside the IC can be configured independently of the others, allowing an endless variety of matrix designs.

All Channel Mode and Single Channel Mode I²C Commands with Flicker-Free PWM and Fade

The I²C instruction set includes 1-, 2- and 3-word commands. These commands are sent over the serial data line (SDA) alongside the master-generated clock line (SCL) at up to 400 kHz speed. The master microcontroller sends all channel mode (ACM) or single channel mode (SCM) write commands to control the brightness, fade, open-circuit threshold and short-circuit threshold of the LED channels and LT3965 addresses.

Broadcast mode (BCM), ACM and SCM read commands request that the drivers report the content of their registers, including open and short registers for fault diagnostics. The matrix LED driver asserts an ALERT flag when there is a new fault. The micro can respond to the fault by determining which driver reported the fault, as well as the type and channel of fault. In the case that multiple ICs are reporting faults, they can sequence fault reporting to the master to prevent overlap errors. This makes the alert response system reliable and conclusive. A complete list of the registers and command set is given in the data sheet.

ACM write commands instantly turn all of the eight channels of a single LT3965 address on or off with just two I²C words - the channels transition on or off at the same time. Turning a high number of LEDs on or off presents a significant current voltage load step to the DC/DC converter. The converters presented here handle these transients with grace, with little or no output capacitor and high bandwidth.

As shown in Figure 8, an ACM write transitioning a high number of LEDs produces no visible flicker or significant transient on the LED current of other channels.

The high bandwidth buck mode converter built around the LT3797 is the reason for such a small and controlled transient.

Single channel mode writes produce relatively small and fast single-LED transients. SCM writes are used to set the brightness of only one channel at a time to ON, OFF, or PWM dimming with or without fade. PWM dimming values between 1/256 and 255/256 are communicated in 3-word writes while ON and OFF can be communicated in shorter, 2-word commands. A fade bit on a single SCM write command enables the LT3965 to move between two PWM dimming levels with internally determined logarithmic fade and no additional I²C traffic. The open and short thresholds of each channel can be set between one and four LEDs with SCM write commands.

Short and Open LED Fault Protection for Each Channel

Short- and open-circuit protection is an inherent benefit of this matrix dimmer. Each channel's NMOS power switch can shunt out between one and four series LEDs. Traditional LED strings have protection against the entire string being open or shorted and only some ICs have output diagnostic flags to indicate these fault conditions. In contrast, this driver protects against, and rides through, individual channel shorts and opens, keeping operational channels alive and running while recording and reporting the fault conditions.

When a fault occurs within a string, the driver detects the fault and asserts its ALERT flag, indicating to the microcontroller that there is an issue to be addressed. If the fault is an open-circuit, the driver automatically turns on its corresponding NMOS power switch, bypassing the faulty LED until a full diagnosis occurs or until the fault is removed.

The IC maintains registers of open and short faults for each channel and returns the data to the microcontroller during I²C fault read commands. The command set includes reads that leave the status register unchanged and those that clear the fault registers, allowing user-programmable fault diagnostics.

Registers can be read in the various modes allowed for writes, SCM, ACM, BCM:

- Single channel mode (SCM) reads return the open and short register bits for a single channel. SCM reads also check the open and short threshold register, the mode control, and the 8-bit PWM dimming value for that channel
- All channel mode (ACM) reads return the open and short register bits for all channels of a given address without clearing the bits, as well as the ACM ON and OFF bits for all eight channels
- In more complex systems with many matrix dimmers sharing the same bus, a broadcast mode (BCM) read first requests which, if any, IC address has asserted the fault flag
- The ACM and SCM reads can be used to check and clear faults and to read all of the registers for a robust I²C communications system

Up to 16 Addressable Drivers on the Same Bus

Every IC features four user-selectable address bits, enabling 16 unique bus addresses. Every ACM and SCM I²C command is sent to the shared communications bus, but action is only taken by the addressed IC. BCM commands are followed by all ICs on the bus. The 4-bit address architecture allows a single microcontroller and a single I²C 2-line communications bus to support up to $8 \times 16 = 128$ individually controllable channels. With this driver, for all but the most ambitious lighting displays, all individual LEDs in an automobile's headlight, tail light and trim lights can be controlled by a single I²C communications bus and a single microcontroller. Given that each channel can be connected to up to four LEDs, one relatively easy-to-implement system can support matrix dimming for up to 512 LEDs.

Conclusion

The matrix LED dimmer controls eight LED-brightness channels on a single LED string, giving lighting designers unlimited access to sophisticated and striking automotive lighting designs. The I²C communications interface allows a microprocessor to control the brightness of individual LEDs in the string. Fault protection in the I²C interface ensures LED lighting system robustness. The channels of the matrix dimmer are versatile: each channel can control multiple LEDs; channels can be combined to support higher current LEDs; or high LED-count systems can be produced with up to 16 matrix dimmer ICs on the same communications bus. The time has come to take the next step in designing automotive headlights, tail lights, front, side, dash and trim lights. ■

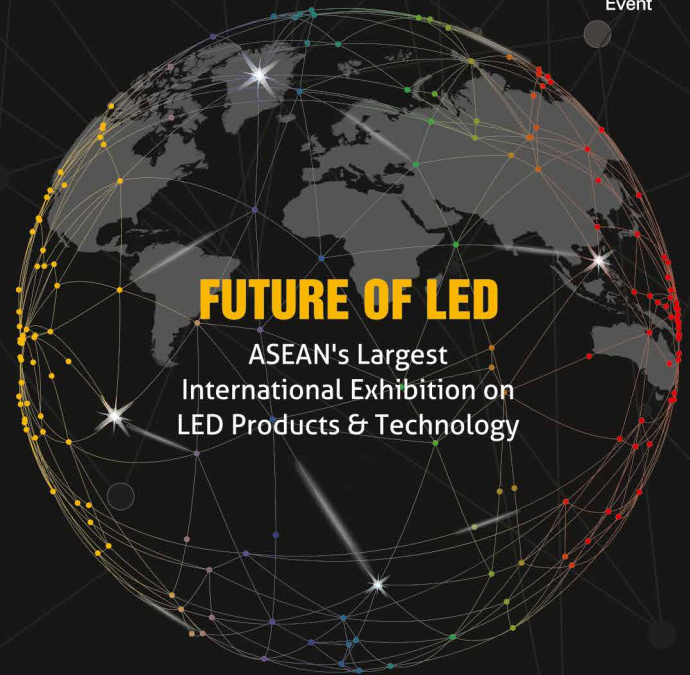
THAILAND
LED
EXPO 2018
10-12 MAY, 2018
CHALLENGER 1
**IMPACT EXHIBITION & CONVENTION
 CENTER BANGKOK, THAILAND
www.ledexpo-thailand.com**
**DO YOU WANT TO BE A LEADER
 IN THE LED LIGHTING INDUSTRY
 IN THAILAND AND ASEAN?**
ORGANIZERS

MEX Exhibitions Pvt. Ltd.

 9 LGF, Sant Nagar, East of Kailash, New Delhi-110065, India
 Ms. Himani Gulati Tel.: +91-9312285142, E-mail: himani@mexexhibits.com
 Mr. Gaurav Juneja Tel.: +91-9810301644, E-mail: gaurav@mexexhibits.com

IMPACT Exhibition Management Co., Ltd.

 Bangkok Land Building, 10 Floor, 47/569-576, Moo 3, Popular 3 Road,
 Banmai Sub-district, Pakkred District, Nonthaburi 11120
 Ms. Panvisut Buranakarn (Opal): Tel: +66 (0) 2833 5328, Email: panvisutb@impact.co.th
 Ms. Wong Wing Yan: Tel: +66 (0) 2833 5013, Email: wingyanw@impact.co.th

**BOOK YOUR
 SPACE NOW!**



LED professional Review (LpR) - Annual Subscriptions

LpR Digital Magazine

- 6 issues
- pdf download
- high resolution pictures and graphs
- printable
- commercial use
- access to all previous issues
- Euro 78.80

LpR Printed Magazine

- 6 issues
- Euro 158.40

<http://www.led-professional.com/subscription>

Cover-page

Artwork: Thomas Klobassa,
©LED professional 2017

Main Image: Arno Grabher-Meyer,
LED professional



Smart retrofit LED bulb from Blume Labs, a startup company from the UK that exhibited at TiL 2017 in Bregenz

Next LpR

SMART SYSTEMS & SOLUTIONS
L+B Issue 66 - March/April 2018

TECH-TALKS BREGENZ

Fred Maxik - Founder and CEO,
Lighting Science Group

LpS 2017 Keynote speaker Fred Maxik is one of the most innovative pioneers in LED lighting and thought about "Human Centric Lighting" long before this trend became popular. LED professional talked about his ideas, the technology and future prospects. ■

RESEARCH

"Best Papers" at LpS 2017:
Lifetime- and Economic Efficiency
Simulation of LED Luminaires

The lifetime of an LED system is usually specified by the LM-80 report using the TM-21 method. Unfortunately, this value is solely valid for one specific application. Despite these uncertainties, a new open-source Modelica library for dynamic simulation of LEDs parametrized with manufacturer information, e.g. the datasheet, but still provide sufficient accuracy to evaluate the lifetime and the corresponding economic efficiency of LEDs and to dimension all relevant components. ■

TECHNOLOGIES

Preventing Electrical Over Stress - How to
Prevent an LED Failing Earlier than Expected

LEDs are basically pretty robust light sources, but there are still conditions that lead immediately to a fatal failure. One is electrical overstress. All aspects when a LED fails due to a voltage beyond its specification limits and reasons why the failure occurs will be explained as well as how to prevent this. The fundamental aspects of a good PCB layout design and how this is linked to longevity of an LED will be explained. ■

Method and Circuit to Maintain Constant
Light Output for LED Luminaires

For LED luminaires, it is difficult to accurately predict the lifetime or the light output degradation. A Constant Light Output (CLO) operation is implemented in some of the latest drivers. However, there are many factors which require a different algorithm in terms of time rate and forward current values which are usually not taken into account. A new method is maintaining the luminous flux over the lifetime of the LED luminaire, considering the luminaire global light degradation. ■

A Hybrid Light Source for Near
Infrared Enhanced LED Lighting

With the evolution of LED lighting, Human Centric Lighting (HCL) became an important trend. While HCL is not clearly defined, a common understanding is that this is light and lighting that supports health and well-being of humans. Some newer proposals are going beyond this approach by providing invisible radiation for which research and the evolution of humans show evidence for positive health and well-being effects. A new approach that adds NIR radiation to LED illumination is discussed. ■

subject to change

Imprint

LED professional Review (LpR), ISSN 1993-890X

Publishing Company

Luger Research e.U.

Institute for Innovation & Technology
Moosmahdstrasse 30
A 6850 Dornbirn, Austria / Europe
phone +43 5572 39 44 89
fax +43 5572 20 60 70
info(at)lugerresearch.com
www.lugerresearch.com

Publisher

Siegfried Luger +43 699 11 33 55 70
s.luger(at)led-professional.com

Editor-in-Chief

Arno Grabher-Meyer +43 699 11 33 55 18
a.g-m(at)led-professional.com

Int. Account Manager

Theresa Koenig +43 699 11 33 55 20
theresa.koenig(at)led-professional.com

MarCom Manager

Bronwen Rolls +44 797 401 2962
bronwen.rolls(at)led-professional.com

Your Sales Contacts

Int. Sales Manager

Brigitte Lindner +43 699 11 33 55 19
brigitte.lindner(at)led-professional.com

China, Hong-Kong

Iris Yuen +86 1380 27 01 367
irisyuen88(at)gmail.com

Germany

Armin Wezel +49 30 526 891 92
armin(at)eurokom-media.de

India

Priyanka Rai +91 124 478 7331
priyanka.rai(at)binarysemantics.com

Japan

Eiji Yoshikawa +81 3 6751 0090
scala(at)s3.dion.ne.jp

South Korea

Jung Won Suh +82 2 78 58 222
sinsegi-2(at)sinsegi-media.info

Taiwan

Leon Chen +886 2 256 81 786-10
leon(at)jkmedia.com.tw

UK, Ireland, Benelux, Scandinavia

Zena Coupé +44 1923 85 25 37
zena(at)expomedia.biz

US East

Karen C Smith-Kernc +1 717 397 7100
KarenKCS(at)aol.com

US West & Canada

Alan A. Kernc +1 717 397 7100
AlanKCS(at)aol.com

Copyrights - Luger Research e.U.

The editors make every reasonable effort to verify the information published, but Luger Research e.U. assumes no responsibility for the validity of any manufacturers, non profit organizations or individuals claims or statements.

Luger Research e.U. does not assume and hereby disclaims any liability to any person for any loss or damage caused by errors or omissions in the material contained herein, regardless of whether such errors result from negligence, accident or any other cause whatsoever. You may not copy, reproduce, republish, download, post, broadcast, transmit, make available to the public, or otherwise use LED professional Review (LpR) content without prior written consent from Luger Research e.U. - Institute for Innovation & Technology, Austria. ■



! GET YOUR FREE E-MAGAZINE
www.led-professional.com/free



The Global Information Hub for Lighting Technologies

LED professional is the comprehensive publication and platform, connecting experts in the design, testing and production of the latest lighting technologies information from around the world.

LED
professional

MORE THAN
31,500
READERS

www.led-professional.com

powered by Luger Research e.U.

Please visit us at the
embedded world Nürnberg
on our booth: Hall 1, Stand 1-560



Luminosity – No Shadowing



Minimal shadowing, optimal light distribution: WAGO offers a wide product range for all LED applications. Smallest dimensions, international approvals and WAGO's universal Spring Pressure Connection Technology enables the worldwide use. The all-new Through-Board SMD PCB Terminal Blocks 2070 Series transfer the wiring to the back-side of LED modules. Thus, undesired shadowing will be reduced to the minimum and wiring of luminaires will be simplified. **We Connect Your Light.**

www.wago.com/smd

